

DESIGN AND TESTS OF ELECTRONIC MANAGEMENT SYSTEM FOR SMALL MOTORCYCLE SPARK IGNITION ENGINES

Fabício J. P. Pujatti, pujatti@demec.ufmg.br

Departamento de Engenharia Mecânica – DEMEC/UFMG
Av. Antônio Carlos, 6627, Belo Horizonte/MG, CEP 31.270-901

Marcos A. S. Mendes, marcos@cpdee.ufmg.br

Departamento de Engenharia Eletrônica – DELT/UFMG
Av. Antônio Carlos, 6627, Belo Horizonte/MG, CEP 31.270-901

Gabriel T. Braga, gabriel.braga@pwplab.com

Valdênio M. Araújo, valdenio@pwplab.com

PWP Lab Sistemas Eletrônicos Ltda – PWP Lab
Rua Ministro Orozimbo Nonato, 392 – Galpão 06, Belo Horizonte/MG, CEP 31.260-230

***Abstract.** The third phase of Brazilian Program for Pollution Control in Motorcycles – PROMOT III, in force since 2009, establishes gradual introduction of emission control for this category of vehicles. The manufacturers from this industry segment need to adapt their products to newly established limits, either through modifications of the conventional systems or through adoption of electronic management systems (EMS). This paper presents the development and implementation of an electronic management system for small motorcycle engines and a comparative study of the emission levels obtained through the introduction of this technology and the emission levels of the conventional systems to control the air/fuel mixture and their ignition (conventional carburetor + Capacitive Discharge Ignition – CDI). It also presents the substitution of the conventional systems by electronic management systems to provide a control emissions as well as the benefits of the new systems in fuel economy, drivability and engine durability.*

***Keywords:** electronic management system, fuel injection, motorcycle engine*

1. INTRODUCTION

The development of Electronic Management Systems (EMS) for small spark ignition engines enables the new motorcycles reach the limits set by PROMOT III, in force since January 2009, allowing the progressive reduction of pollutants emission (Braga, 2010). PWP Lab, in partnership with FAPEMIG, made a market study to identify potential applications for this system. This study showed that over 90% of the new motorcycle market is made up of two cylinder engines with total volumetric displacement up to 0,6 liter (600 cm³). This fact directed the development for a system able to attend this market demand, where the main purpose was the representative Brazilian motorcycles manufacturers.

This paper presents the EMS application in a commercial motorcycle powered by a small single cylinder engine (125 cm³), focus on required changes to installation and the emission reduction results with this application. For this purpose were developed and tested the components of an EMS: Electronic Control Unit (ECU), Throttle Body Intake manifold, fuel pipes, fuel pump module, wires and peripherals, software control and strategies necessary to this system. Emission Tests were conducted in chassis dynamometer, simulating the conditions defined by European Communities Directive No. 97/24/EEC for this motorcycles category.

The tests show that the EMS developed by PWP Lab is able to control small motorcycle engines and present a significant reduction in emissions of pollutants, making the motorcycle approved in respect to PROMOT III limits. This market is still in need of the solution presented, showing a great interest in short period of time. At present, an EMS represented an additional characteristic but, for the next years, may become a requirement of market.

2. METHODOLOGY

2.1 Object of Study

A study of motorcycle initial configuration was done to determine the actual state of the art in order to identify to actions being taken to adapt the actual manufactured motorcycle to the new requirements of Emissions. Table 1 shows the technical details of the motorcycle used in the tests in order to describe the object of study. The choice of model was

done according to a market study conducted by PWP Lab in order to determine the market with the greatest possibility of penetration of the developed system.

Table 1. Motorcycle technical data.

Engine:	Single cylinder, 4 strokes, OHV
- Displacement	124,5 cm ³
- Bore x Stroke	56,5 x 49,5 mm
- Maximum Brake Power ¹	12,5 cv @ 8500 RPM
- Maximum Brake Torque ¹	0,92 kgfm @ 7000 RPM
Production in 2007 ²	31.766 units (1,8% of market)
Price	R\$ 4.700,00

In addition of market study, the choice of the model presented in Table 1 was also based on the possibility of expanding the application of the system to other Brazilian Manufacturers, whereas most produce similar models. The Emission Tests was realized at Emission Vehicle Laboratory – LEV at Fundação Centro Tecnológico de Minas Gerais - CETEC.

Some modifications were needed to bring the lab to run tests on motorcycles. Interventions were performed in existing equipment in the laboratory and in the brackets of the motorcycle (Vinti, 2010). Were designed and built three individual devices, shown in Figure 1, to enable the attachment of motorcycle from front wheel (Figure 1-a) adoption of side belt holders (Figure 1-b) and installation of a mechanical protection for chassis dynamometer (Figure 1-c).

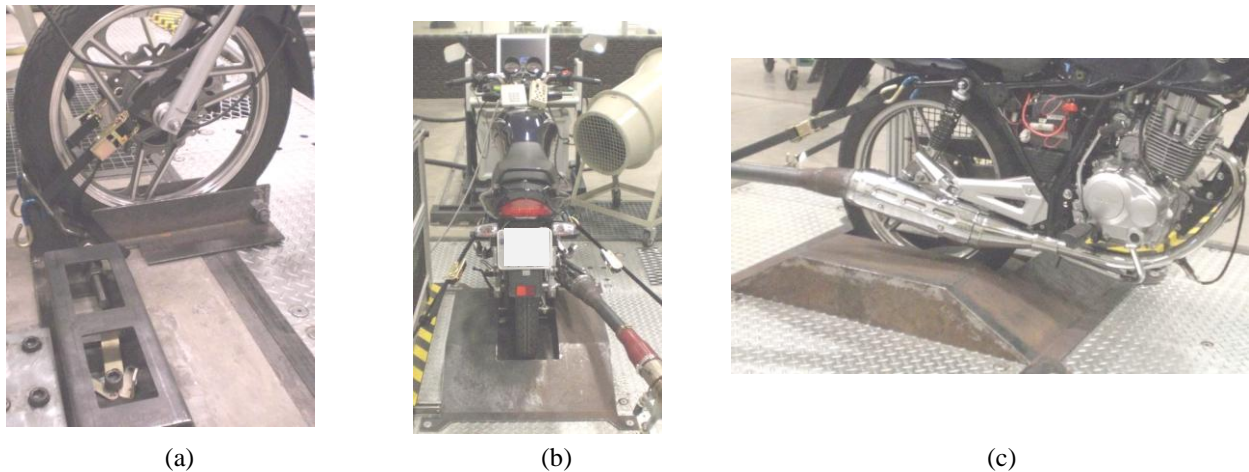

Figure 1. Mechanical assembly to fix the motorcycle at chassis dynamometer. (a) Front wheel (b) Side belt holders (c) Chassis dynamometer protection (Vinti, 2010).

The standard cycle used during emission tests followed to the requirements of Annex II of the European Community Directive No. 97/24/EEC, specifically for motorcycles and similar. Figure 2 shows the velocity diagram in function of time.

¹ Technical Data declared by Manufacture, using Brazilian Gasoline, according to Normative ABNT/NBR 1585-1996.

² Reference: Associação Brasileira dos Fabricantes de Motocicletas, Ciclomotores, Motonetas, Bicicletas e Similares – Abraciclo. (www.abraciclo.com.br)

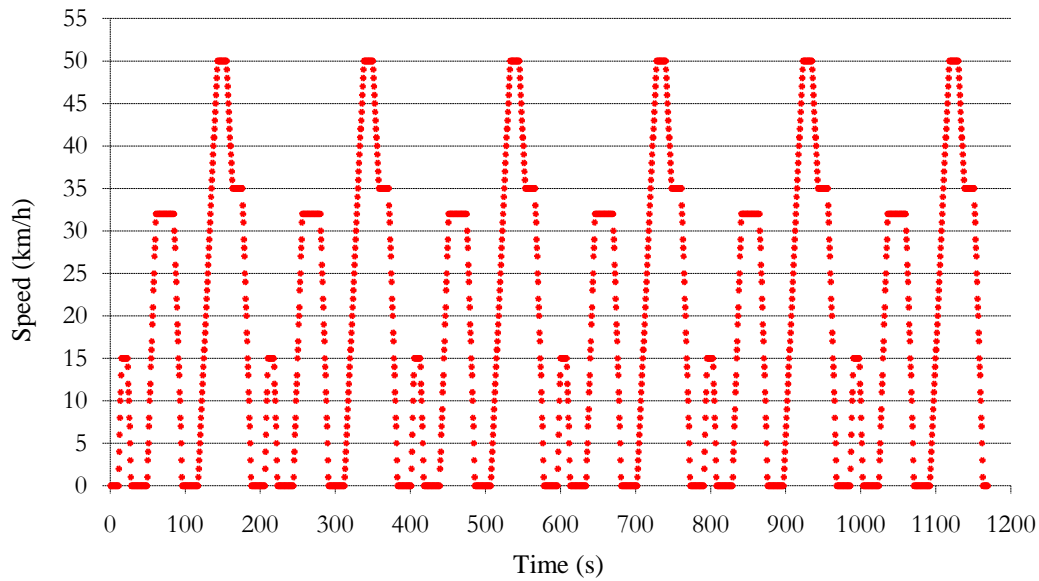

Figure 2. Standard Cycle used in emission tests - European Community Directive No. 97/24/EEC.

The emission tests performed on the motorcycle in its original setup (air/fuel mixture controlled by conventional carburetor) confirmed the necessity of EMS to enable the motorcycle approved in respect to PROMOT III limits. The results obtained in this configuration are presented in Table 2 with the limits for Phase II (Jan/06) and Phase III (Jan/09) cited as a reference. All measurements are given in grams per kilometer in the cycle (g/km), and the results obtained from an average of three tests under the same conditions, to reduce the experimental error.

Table 2. Emission results of motorcycle in original setup and PROMOT limits.

Directive nº 97/24/EEC			
Pollutant	Results	PROMOT II (jan/06)	PROMOT III (jan/09)
Carbon Monoxide – CO	3,88 g/km	5,5 g/km	2,0 g/km
Unburned Hydrocarbon – UHC	0,93 g/km	1,2 g/km	0,8 g/km
Nitrogen Oxides – NO _x	0,19 g/km	0,30 g/km	0,15 g/km
³ Carbon Dioxide – CO ₂	48,33 g/km	-	-
Status		Approved	Disapproved

2.2 Design and Manufacture of Mechanical Modifications

A careful study of the motorcycle systems was conducted to minimize the necessary changes, reducing the costs of electronic management system installation. 3D models were design for all new/modified system and are listed below, with the justification of intervention:

- Intake Manifold: replacement of standard carburetor (throttle + fuel injector);
- Magneto Rotor: speed and position of crankshaft indication;
- Fuel Tank: Assembly of fuel pump module;
- Fuel lines: increase fuel pressure and layout;
- Wires: Connections of power supply, sensors and actuators;
- Exhaust manifold: Introduction of Oxygen Sensor (air/fuel mixture in closed control loop).

This study allowed the adjustment of developed system to the motorcycle, avoiding great changes in productive process in an attempt to reduce the cost associated with in scale production. The main changes occurred in intake manifold (substitution of carburetor), magneto rotor, making possible the determination of position and angular speed of crankshaft, and fuel tank. Figure 3 shows 3D models design for this application (Vinti, 2010).

³ There isn't limit set by PROMOT for Carbon Dioxide emissions (CO₂). The value obtained is showed by a reference.

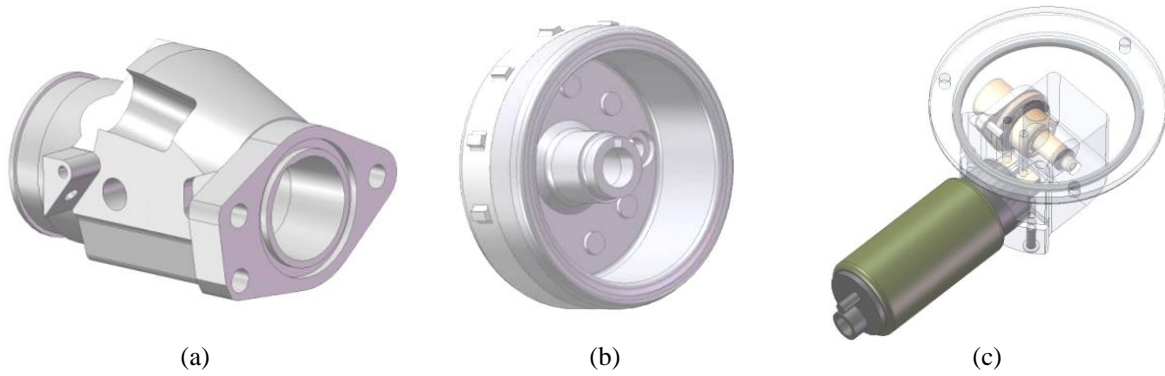

Figure 3. 3D models of (a) intake manifold (b) magneto rotor and (c) fuel pump module (Vinti, 2010).

2.3 Design and implementation of Hardware and Software

The hardware and software specifications were defined for the development of electronic document management system and assembled on the motorcycle. Table 3 lists the specifications of hardware for use in motorcycle engines. The main characteristic is the possibility to expand their use in motorcycles up to two cylinders and volumetric capacity up to 600 cm³. This feature makes the system able to control 88% of motorcycles sold in the Brazilian market.

This systems were designed and built by PWP Lab and are called *Pwjetronic*[®]. In the tests presented in this paper, the PW 600 series was used to control the motorcycle engine. The Figure 4 presents a schematic diagram of *PW 600 Electronic Management System*.

Table 3. Hardware specifications.

<i>Hardware of Control Engine</i>	
Driver for ignition coils	02 TSI ⁴)
Driver for fuel injectors	02 (port injection)
Sequential indirect injection	Yes
Driver for Idle Air Control (IAC)	02 “H” bridge
Measure of exhaust O ₂ concentration (HEGO)	01 (<i>Narrow band Sensor</i>)
Measure of crankshaft position and angular speed (CKP)	01 (VR ⁵)
Measure of Intake air temperature (ACT)	01 (NTC ⁶)
Measure of Intake engine temperature (ECT)	01 (NTC)
Measure of absolute intake air pressure (MAP)	Transducer
Measure of throttle position (TPS)	Linear potentiometer
Failure detection of actuators (self-diagnostic)	Yes
Detection, storage and failure communication	Yes
IP Class (Case + connector)	>55
Fuel pump switch	01
K-Line for diagnostic	01 (RxTx ⁷)
External Dimensions	140 x 80 x 30 mm

⁴ Transistorized Ignition for inductive coil.

⁵ Variable Reluctance Sensor.

⁶ Negative Temperature Coefficient.

⁷ RxTx: Communication Serial Protocol.

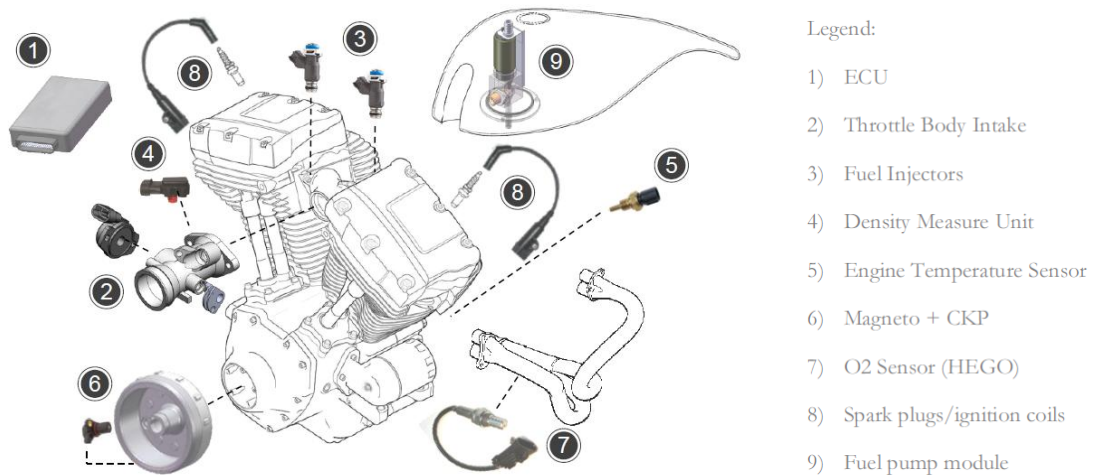

Figure 4. PW 600 Electronic Management System schematic diagram.

The ECU hardware consists of power drives for the actuators (coils, fuel injectors for example), power supply, reference circuits, interface for communications modules and external memory. The TMS28027 Digital Signal Processor (DSP) adoption made possible to reduce costs, physical size and hardware simplification, since many features are implemented by the integrated peripheral component. The Figure 5 shows a block diagram of the ECU hardware and peripherals of the Digital Signal Processor (DSP) used.

Defined the specifications of the hardware were made circuit design, the definition of components and board layout. An important feature to note is the external dimensional circuit restriction due to limited physical space to boarding ECU on motorcycle.

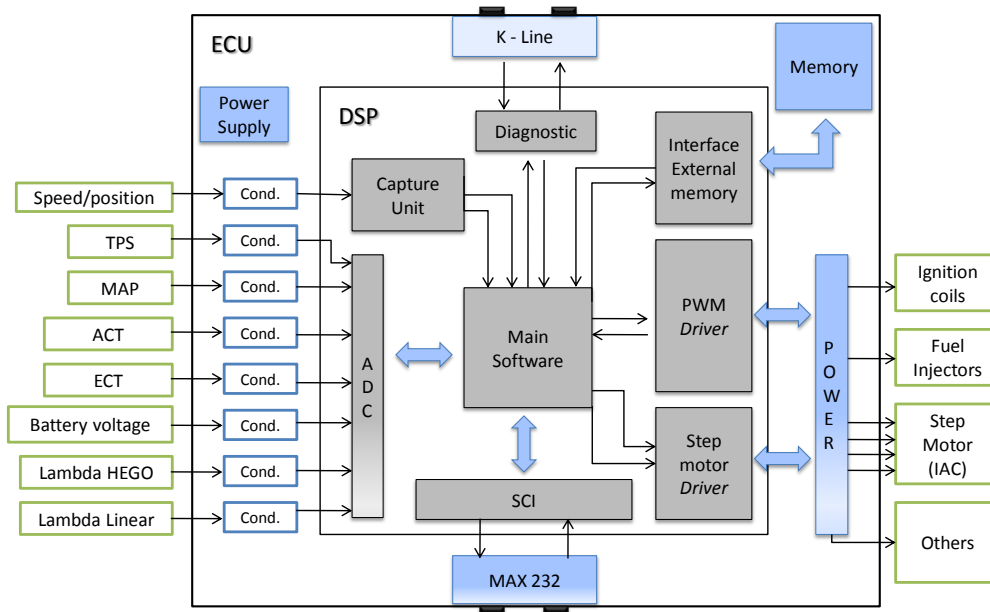

Figure 5. Block Diagram of ECU hardware.

Completed the schematic circuits design were defined the dimensions of the circuit board and the number of layers. The Printed Circuit Board (PCB) was developed by PWP Lab staff in partnership with others, through service development layout circuit board. Were defined the allocation connector, width of source and pads, ground and supply layers. Electromagnetic compatibility (EMC) studies to determine the position of electronic components. Through this study has been possible to develop a board layout optimized for size, with specific regions for each type of signal, in agreement with standards of EMC. Due to the high density of components and the PCB tracks, a 4 layers solution were choose. Figure 6 shows 3D model of ECU board (Figure 6-a) and the 3D model of case ECU (Figure 6-b).

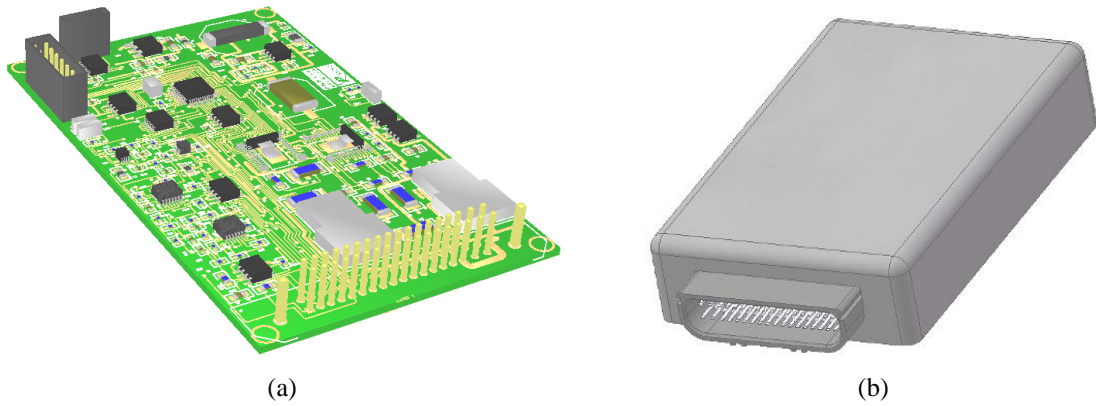

Figure 6. ECU board (a) 3D board model and (b) 3D ECU model.

3. RESULTS AND DISCUSSION

The conclusion of design enabled the construction of these components, whose purpose was to perform functional tests of systems and subsystems designed. The first change was the replacement of conventional carburetor by Throttle Body Intake manifold with fuel injector integrated. Figure 7 presents the Throttle Body Intake manifold design (Figure 7-a) the new magneto rotor with reference teethes (Figure 7-b) and the electrical fuel pump module (Figure 7-c).

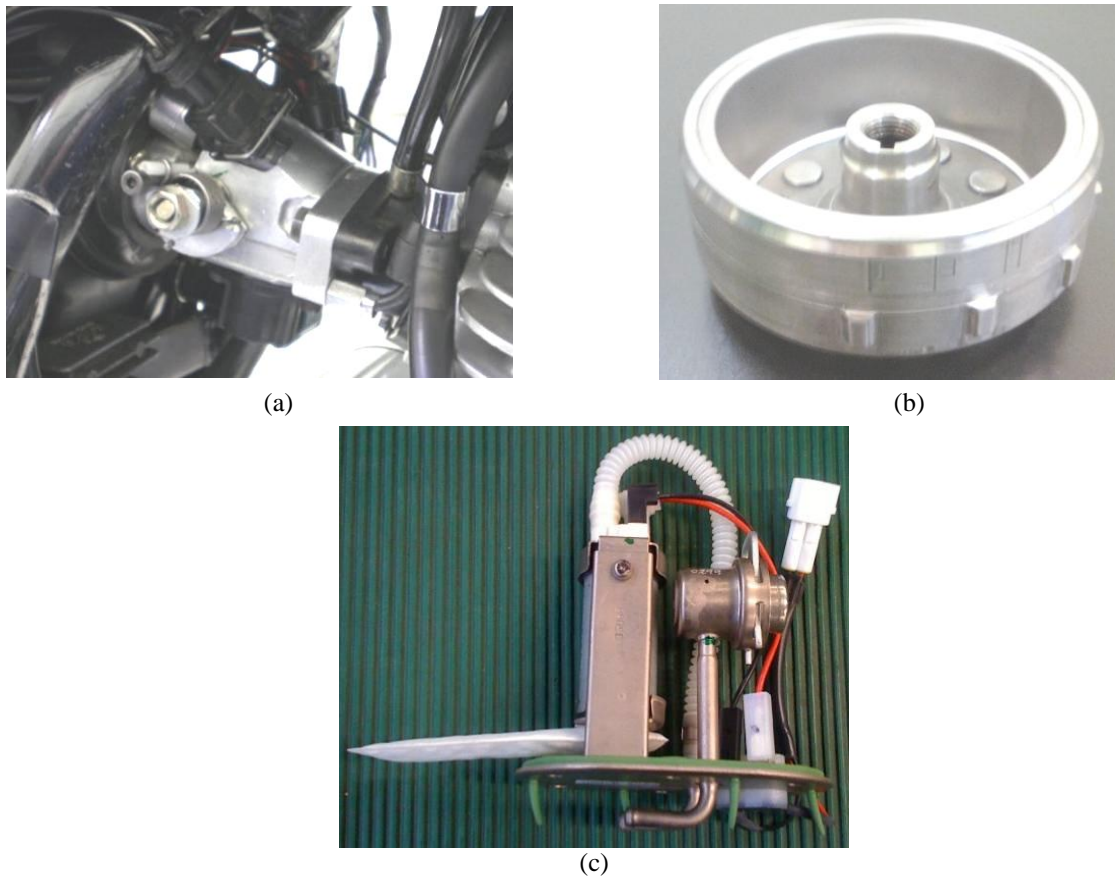

Figure 7. Mechanical components (a) Throttle Body Intake manifold, (b) new magneto rotor and (c) Fuel pump module used in tests.

The main advantage of this solution is compatibility with the carburetor assembly location, having identical dimensions of the flanges. The Throttle Body Intake has a series of electronic and mechanical components that control and monitor the intake system, connecting it to the ECU, which: throttle valve, idle air control, fuel injector, throttle position sensor and air flow characteristics. This TBI prototype made possible to test the electronic system (ECU) and begin developing solutions for serial large scale production. The Figure 8 presents the ECU real board assembly with connector and components (Figure 8-a) and the pre-series ECU used in the tests (Figure 8-b).

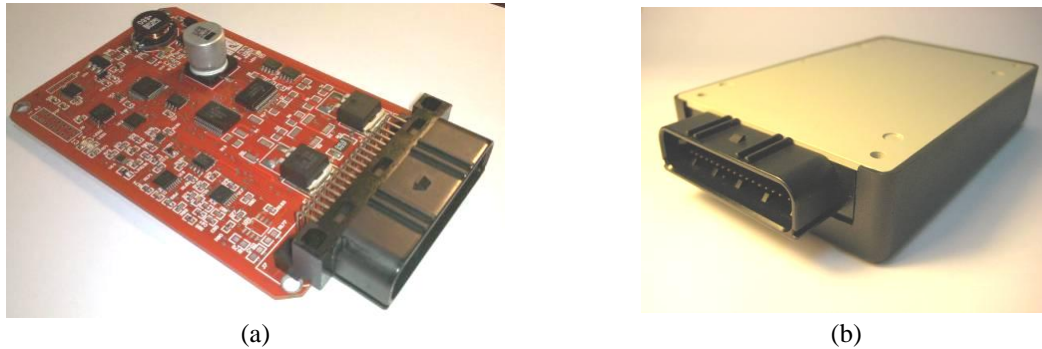

Figure 8. (a) ECU board assembly and (b) pre-series ECU used in the tests.

Similar to hardware specifications, software requirements of engine management specifications were defined and implemented for hardware instructions. The Table 4 shows the specifications of the software developed for application in motorcycles.

Table 4. Software requirements.

Engine Management Control requires	
Air/Fuel mixture control	Closed Loop
Spark timing ignition control	Open Loop
Idle Speed control	Closed Loop
Injection time control	By software
Cold start strategies	Yes
Enrichment acceleration strategies	Yes
Knock detection	No
Multi fuel strategies (Ethanol and Gasoline)	Yes
Diagnostic of sensor and actuators	Yes
Interface (IHM) for development	RS-232/PC
Interface for diagnostic by commercial tools	K-Line Protocol

The application of this system also features dedicated to the calibration maps driving (comfort and drivability), consisting of filters of spark time ignition an air/fuel mixture during the gear shifting and enrichment acceleration throttle response. The onboard software engine control involves input modules of information processing and control of different actuators by table-based functions. These modules are responsible by the engine control and works together with others less priority, as diagnostics and communication functions. The objectives of onboard software are:

- Basic strategies to start single or twin cylinders motorcycle engines;
- Software description as a model to value the modular interfaces and synchronize events;
- Strategies to self-diagnostics and communication;
- Comfort and Drivability strategies;
- Strategies for emission control;
- Strategies for multi-fuel applications.

The complex dynamics of internal combustion engines during operation involves highly non-linear relationships derived from chemical reactions, dynamics of sensors, different friction and losses, fluid dynamics, transport phenomena and more. Their point of operation includes different conditions of speed, load, pressure, temperature and fuels. To control this type of system is necessary to perform nonlinear maps between the variables, including closed-

loop controllers to correct variations in time, and adjust these control loops and the maps for different operating conditions. In the electronic management system developed in this project were used following control strategies:

- Stead-state machine which receives the measured data and determines the operational status;
- Monitoring of the output variables (control actuators) according to the measurements;
- PI controllers for adjust for close-loop control;
- Additional strategies for specific states of control.

The control system developed and implemented in software can be divided into modules: Measurement, Actuation/Control (spark timing ignition control, fuel injection control, idle speed control, actuation of peripheral systems), Communication interface and Data logger. The Measurement and Actuation/Control modules are critical because they are in system control loop.

The Measurement module consists of the elements that interface with the driver for Analog to Digital Converter - ADC, variables calibration, diagnostic and digital filtering. The information obtained is transmitted to the Actuation/Control modules, which calculate and send the commands to be applied in the actuators. The Communication interface and Data logger modules works together (exchanging and sharing data) with main modules.

The emissions tests carried on the motorcycle in your original configuration (air/fuel mixture controlled by conventional carburetor + Capacitive Discharge Ignition – CDI) showed the necessity of reduction emission levels by 50% CO, HC and NO_x by 15% to 30% for the motorcycle reach the limits by PROMOT III, in force since January 2009. It is important that reduction is even greater because the emission levels should be maintained up to 36.000 km. The test is based on the standard cycle defined by the Directive No. 97/24/EC of the European Community.

4. CONCLUSION

This paper presents the development of an electronic management system for small motorcycles engines, able control the actuators of the engine from the information measured by the sensors. The complete system involves the ECU unit, sensors, actuators, wires, connectors and fuel pump module. The tests show that the Electronic Management System developed by PWP Lab, with support from FAPEMIG, is able to control the small engines, since it designed to support the minimum conditions required for combustion.

The implementation of Electronic Management System (EMS) developed by PWP Lab is able to control small motorcycle engines and present a significant reduction in emissions of pollutants, making the motorcycle approved in respect to PROMOT III limits. It's also necessary a durability tests with the design system, but the results obtained until now, could concluded the viability of implementation of *PWjetronic* systems to control motorcycle engines.

The tests show a great potential for the system developed, encouraging more with your conclusion that all the research developed to become a product able to provide a benefit to the environment and society. This market is still in need of the solution presented, showing a great interest in short period of time. At present, an EMS represented an additional characteristic but, for the next years, may become a requirement of market.

5. ACKNOWLEDGEMENTS

The authors would like to thanks FAPEMIG and PWP Lab for financial and technical support.

6. REFERENCES

ABNT. "Associação Brasileira de Normas Técnicas". NBR-1585: Veículos rodoviários, Código de potência de motores, Potência líquida efetiva. Rio de Janeiro: 1996. 26 p.

Braga, G. T., "Desenvolvimento de sistemas de gerenciamento eletrônico de motores de combustão interna aplicados a motocicletas". Relatório de Atividades de bolsista Modalidade da Bolsa: BDTI-III – Projeto PAPPE APQ 0225.6.01/08. Belo Horizonte, agosto de 2010.

Braga, G.T., Uma Contribuição ao Controle de Motores de Combustão Interna de Ignição por Centelha na Condição de Marcha Lenta, Dissertação de Mestrado, Universidade Federal de Minas Gerais, Centro de Pesquisa e Desenvolvimento em Engenharia Elétrica - CPDEE, Julho 2007.

Companhia Ambiental do Estado de São Paulo - Secretaria de Estado de Meio Ambiente.
<http://www.cetesb.sp.gov.br/Ar/emissoes/promot2.asp>

Directive No. 97/24/EEC of the European Parliament and of the Council on certain components and characteristics of two or three-wheel motor vehicles.

Freescale Semiconductor, Automotive Engine Control IC – 33810, Document Number: MC33810, Rev. 8.0, 07/2010.

Freescale Semiconductor, Configurable Octal Serial Switch with Open Load Detect Current Disable – 33879, Document Number: MC33879, Ver 8.0, 10/2009.

Freescale Semiconductor, ISO K Line Serial Link Interface 33290, Document Number: MC33290, Ver. 8.0, 08/2008.

Ganesan, V., “Internal combustion engines”. 1. ed. New York: McGraw-Hill, Inc., 1995. 540 p.

Heywood, John B., “Internal combustion engine fundamentals”. 1 ed. New York McGraw-Hill, Inc., 1995. 930 p.

Nagashima, M.; Levine, W. S. Development of an engine idle speed and emission controller, IEEE American Control Conference, Junho 2006.

Pujatti, F. J. P., Desenvolvimento de um sistema de gerenciamento eletrônico para pesquisa em motores de ignição por centelha, Tese de Doutorado. Programa de Pós-graduação em Engenharia Mecânica - UFMG. Belo Horizonte - MG. 215 p., agosto 2007.

RESOLUÇÃO CONAMA n. 297. Programa de Controle da Poluição do Ar por motocicletas e Veículos Similares – PROMOT, fevereiro de 2002.

Semenchenko, A., “Desenvolvimento de sistemas de gerenciamento eletrônico de motores de combustão interna aplicados a motocicletas”. Relatório de Atividades de bolsista Modalidade da Bolsa: BDTI-III – Projeto PAPPE APQ 0225.6.01/08. Belo Horizonte, agosto de 2010.

Scillieri, J. J.; Buckland, J. H.; Freudenberg, J. S. Reference Feedforward in the Idle Speed Control of a Direct-Injection Spark-Ignition Engine. IEEE Transactions on Vehicular Technology, vol 54, N° 1, janeiro 2005

Texas Instruments, Piccolo Microcontrollers Data Sheet - SPRS523E –TMS320F28027 Nov 2008 – Revised April 2010, <http://focus.ti.com/lit/ds/sprs523e/sprs523e.pdf>

Texas Instruments, Serial Peripheral Interface, Reference Guide - SPRU566I, June 2003-Revised May2009, <http://focus.ti.com/lit/ug/spru566i/spru566i.pdf>

Vinti, M. N. W., “Desenvolvimento de sistemas de gerenciamento eletrônico de motores de combustão interna aplicados a motocicletas”. Relatório de Atividades de bolsista Modalidade da Bolsa: BAT-III – Projeto PAPPE APQ 0225.6.01/08. Belo Horizonte, agosto de 2010.

7. RESPONSIBILITY NOTICE

The authors are the only responsible for the printed material included in this paper.