

ADAPTIVE CONTROL APPLIED TO TWO LINKS OF A CARTESIAN ELECTROPNEUMATIC MANIPULATOR ROBOT OF THREE DEGREES OF FREEDOM

Oldineia Batista de Souza, oldineia@gmail.com

José Antônio Riul, riul@ct.ufpb.br

Anrafel Silva Meira, anrafel_meira@hotmail.com

Paulo Henrique de Miranda Montenegro, paulo@ct.ufpb.br

Universidade Federal da Paraíba (UFPB) – Cidade Universitária – João Pessoa – PB – Brasil – CEP: 58051-900

Abstract. *The objective of this work is to control in real-time two links of a Cartesian electro-pneumatic manipulator robot with three degrees of freedom (3DOF). The manipulator robot basically consists of three proportional electro-pneumatic valves and three pneumatic cylinders, and their parameters are identified in real-time by the Recursive Least Squares (RLS) method. Self-tuning controllers of Dahlin Minimum Variance (DMV) are designed with the identified and implemented parameters. Finally, experimental results are presented to verify the performance of the manipulator robot's links.*

Keywords: *robotics, identification, self-tuning controller*

1. INTRODUCTION

The objective of this work is to design adaptive controllers for two links of a electro-pneumatic manipulator robot of three degrees of freedom (3 GDL) Cartesian. The robot consists of three prismatic links, which are three pneumatic cylinders, parallel to the axes: X, Y and Z in a Cartesian reference system, and are driven by electro-pneumatic proportional valves. The links are called X, Y and Z, since they move parallel to the axes X, Y and Z Cartesian reference system. A mathematical model of a system can be obtained by physical laws, known as white box model or by parametric identification techniques, known as black box models that rely on system's real data.

The parametric identification technique is used in real time to obtain the parameters of the links X and Z, analyzed in this paper. This type of mathematical modeling is widely used in the design of explicit adaptive controllers, since the update of the parameters of the links to each sampling period incorporates real features and dynamic variations of the system.

To obtain the data for identification, electro-pneumatic proportional valves that drive the X and Z links of the manipulator, are excited in an open loop, by a step function, and the responses of these links, are picked up by potentiometric rules. The links of the manipulator robot are identified in real time by the Recursive Least Squares (RLS) method, from a predefined structure for each link and the parameters obtained are used in the designs of adaptive controllers. Two DMV (Dahlin minimum variance) controllers are designed and implemented with change, so the system meets the performance specifications required, considering a reference for each link of the robot.

2. SYSTEM DESCRIPTION

The electro-pneumatic manipulator robot with three degrees of freedom (3DOF), as shown in Fig.(1) is composed by three robot links parallel to axes: X, Y and Z from the reference system. This robot is Cartesian and has three prismatic joints, resulting in a three translations movement, whose axes of motion are coincident with a Cartesian reference system, thus models of the links are uncoupled.

The links are three pneumatic cylinders. As Figure (1) the link Z carries the links X and Y. In this work, the links X and Z will have their positions tracked while the Y link will remain in a fixed position.

The manipulator robot works this way: the compressor supplies compressed air to 24 VDC proportional electro-pneumatic valves (5) and 0-5 VDC analogic signals, that set the double-action and simple rod pneumatic cylinders (1) in motion, carrying out the effector organ. A input-output board is used to excite the valves and to pick up the signals measured by the potentiometric rulers.

The Figure (1) presents an overview of the system, composed of the following components:

- Three pneumatic cylinders with double acting and single rod, CWEA 03273310-03273310-X0400 and X0200 CWEA of Werk-Schott. The X and Z links, both with 400 mm of course, and the link Y, with 200mm of course;
- Three electro-pneumatic proportional valves, MPYE-5-1/8-HF-010-B from Festo, which are powered with 24 VDC and analog from 0 to 5 VDC, which powers the cylinders;
- Three potentiometric rulers, MLO-POT-TLF-500 from Festo, which measures the positions of the rods of pneumatic cylinders;

A PC computer is used to send actuation of valves command and receive signals from potentiometric rules. The communication between the robot and the computer is accomplished through two input and output data cards, NI USB-6009 and LabView and Matlab softwares.

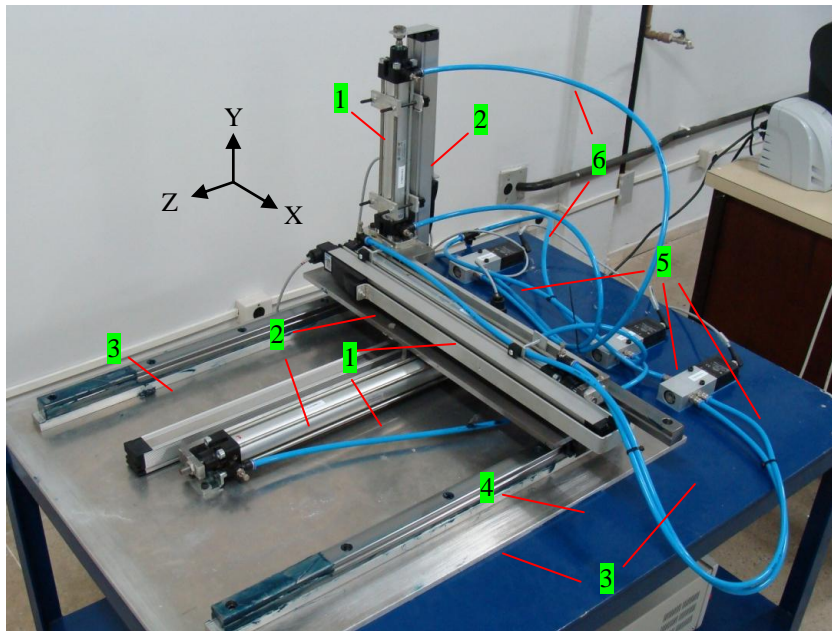

Figure 1- Electro-pneumatic manipulator robot of 3 DOF Cartesian, formed by: 1-pneumatic cylinders; 2-potentiometric rulers; 3-linear guides; 4-roller bearings; 5- three proportional electropneumatic valves; 6-ducts for conducting air flows.

3. MATHEMATICAL MODELING OF THE SYSTEM

Mathematical modeling of a system can be obtained by physical laws, known as white box identification or white box modeling, by parametric identification techniques, known as black box identification or black box modeling that rely on real data from system, or gray box identification (Aguirre, 2007b), a technique that tries to combine the advantages of both above identifications. The parametric identification is used obtaining the system parameters. Parametric mathematical modeling of systems is widely used in the design of explicit adaptive controllers, since the update parameters for each sampling period aims adequacy of the system characteristics and changes in its dynamics.

For a physical system of one input and one output (SISO) and a disturbance, the difference equation (Aguirre, 2007b; Coelho and Coelho, 2004; Aström and Wittenmark, 1995 and Ljung, 1999) is of the form:

$$\rho(t) = \varphi^T(t)\theta(t) + e(t) \quad (1)$$

Of witch:

$$\varphi^T(t) = [-\rho(t-1) - \rho(t-2) \dots - \rho(t-na) u(t-k) u(t-k-1) \dots u(t-k-nb)] \quad (2)$$

$$\theta(t) = [a_1 a_2 \dots a_{na} b_0 b_1 \dots b_{nb}] \quad (3)$$

Where:

$\varphi^T(t)$ - vector of measurements; $\theta(t)$ - vector of parameters; $u(t)$ - system input; $\rho(t)$ - system output; $e(t)$ - filtered white noise; a_i - poles of the system, $1 \leq i \leq na$; b_j - zeros of the system, $1 \leq j \leq nb$; na - number of poles of the system; nb - number of zeros in the system e k - transport delay.

The estimation algorithm of Recursive least squares (RLQ) is implemented with a forgetting factor which aims to increase the sensitivity of the estimator in the presence of variations in system parameters. The set of equations is given by (Aguirre, 2007b):

$$K(t+1) = \frac{P'(t)\varphi(t+1)}{\lambda + \varphi^T(t+1)P'(t)\varphi(t+1)} \quad (4)$$

$$P(t+1) = \frac{1}{\lambda} \left\{ P(t) - \frac{P(t)\varphi(t+1)\varphi^T(t+1)P(t)}{\lambda + \varphi^T(t+1)P(t)\varphi(t+1)} \right\} \quad (5)$$

Where:

$K(t+1)$ - gain of the RLS estimator with forgetting factor.

$P(t)$ - covariance matrix of the RLS estimator with forgetting factor.

4. ADAPTIVE CONTROLLER

Aström and Wittenmark (1995) and Isermann *et al* (1992) define an adaptive controller as a controller with adjustable parameters and an adjustment mechanism. Different approaches are presented in the literature for adaptive controller, however the most used are (Aguirre, 2007) The Gain Scheduling (GS), Model-Reference Adaptive Control (MRAC) and Self-Tuning Regulator (STR). This work used a STR controller as the technique of self-adjusting Dahlin Minimum Variance (DMV).

The control strategy of the DMV, initially proposed by Khalil, (1992), aimed to combine the strategies of Dahlin and minimum variance, resulting in a robust controller, flexible and with competitive performance. This combination guaranteed zero error in steady state between process output and the reference, but had difficulty controlling systems of non-minimum phase. This problem was solved by Al-Chalabi and Khalil (1994), proposing a change in control law to circumvent the limitation. For this strategy was used the autoregressive model of moving average and exogenous inputs Autoregressive moving average with exogenous inputs (ARMAX) given by equation (6):

$$A(Z^{-1})\rho(t) = Z^{-k}B(Z^{-1})u(t) + C(Z^{-1})e(t) \quad (6)$$

Where: $u(t)$ is the control variable, $\rho(t)$ is the system output, $e(t)$ represents a filtered white noise incident on the system and $A(Z^{-1})$, $B(Z^{-1})$ e $C(Z^{-1})$ are polynomials in Z^{-1} , given as follows:

$$\begin{aligned} A(Z^{-1}) &= 1 + a_1Z^{-1} + \dots + a_{na}Z^{-na} \\ B(Z^{-1}) &= b_0 + b_1Z^{-1} + \dots + b_{nb}Z^{-nb}, b_0 \neq 0 \\ C(Z^{-1}) &= 1 + c_1Z^{-1} + \dots + c_{nc}Z^{-nc} \end{aligned} \quad (7)$$

Given a reference signal, the transfer function of closed loop from strategy of minimum variance based in a cost function minimization for this model, is given by:

$$\rho(t) = Z^{-k} \frac{B(Z^{-1})}{A(Z^{-1})} [w(t) - \frac{G(Z^{-1})}{B(Z^{-1})F(Z^{-1})} \rho(t)] + \frac{C(Z^{-1})}{A(Z^{-1})} e(t) \quad (8)$$

Where:

$$\begin{aligned} F(Z^{-1}) &= 1 + f_1Z^{-1} + \dots + F_{k-1}Z^{-(k-1)} \\ G(Z^{-1}) &= g_0 + g_1Z^{-1} + \dots + g_{ng}Z^{-ng} \\ n_g &= \max(n_a - 1, n_c - k) \end{aligned} \quad (9)$$

The parameters f_i e g_j of polynomials $F(Z^{-1})$ e $G(Z^{-1})$ are obtained from the following polynomial identity:

$$\frac{C(Z^{-1})}{A(Z^{-1})} = F(Z^{-1}) + Z^{-k} \frac{G(Z^{-1})}{A(Z^{-1})} \quad (10)$$

The criterion of Dahlin for the dynamics of the closed loop system can be expressed by transfer function given by Eq. (11):

$$G_{MF} = \frac{(1-p)Z^{-k}}{1-pZ^{-1}} \tag{11}$$

Where: $p = e^{-\lambda T_s}$, $\lambda = \frac{1}{\tau}$, λ is the Dahlin tuning parameter, τ is the time constant of the system T_s is the sampling period. When λ tends to a very high value, p approaches zero and the control is faster. For small λ values, p tends to 1 and the control is slower. For this fact, the parameter p is defined as the Dahlin adjust, by having a limited range values. Thus the parameter p can be adjusted to obtain desired response speed.

The equation of synthesis in open loop equivalent to the Dahlin controller is (Zafirou and Morari, 1985):

$$D_0 = \frac{1}{G_0} \frac{(1-p)Z^{-k}}{1-pZ^{-1}} \tag{12}$$

Where: G_0 is the transfer function of the system being controlled.

The combination of Dahlin's controller with the minimum variance strategy consists in placing Dahlin's controller in series with the closed loop system of minimum variance strategy, given by Eq. (8). Simplifying Eq.(8) with Eq.(10) and neglecting the disturbance, arrives that:

$$G_0(Z^{-1}) = Z^{-k} \frac{B(Z^{-1})F(Z^{-1})}{C(Z^{-1})} \tag{13}$$

Replacing Eq.(13) in Eq.(12), has:

$$D_0(Z^{-1}) = \frac{C(Z^{-1})X(Z^{-1})}{B(Z^{-1})F(Z^{-1})} \tag{14}$$

And,

$$X(Z^{-1}) = \frac{(1-p)}{(1-pZ^{-1})} \tag{15}$$

The Figure 2 shows the DMV controller structure and the plan, through the block diagram. The DMV control law is given by Eq. (16):

$$u(t) = \frac{C(Z^{-1})X(Z^{-1})}{B(Z^{-1})F(Z^{-1})} \left[w(t) - \frac{G(Z^{-1})}{C(Z^{-1})X(Z^{-1})} \rho(t) \right] \tag{16}$$

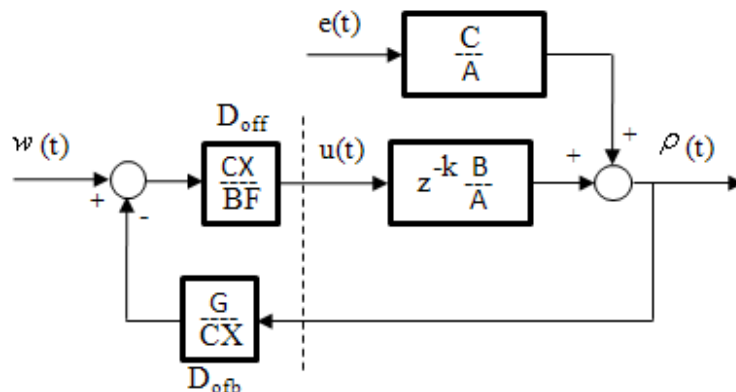

Figure 2- Structure of the DMV controller and the plan

The disadvantage of this structure is the inability to control systems of non-minimum phase. Al-Chalabi and Khalil (1994) get around this limitation with an amendment, which consisted of adding a portion $C(Z^{-1})Q(Z^{-1})$ block on the denominator of the controller directly. Thus Equation (14), becomes:

$$D_{off}(Z^{-1}) = \frac{C(Z^{-1})X(Z^{-1})}{B(Z^{-1})F(Z^{-1}) + C(Z^{-1})Q(Z^{-1})} \quad (17)$$

And the new control law changed to deal with non-minimum phase systems is given by:

$$u(t) = \frac{C(Z^{-1})X(Z^{-1})}{B(Z^{-1})F(Z^{-1}) + C(Z^{-1})Q(Z^{-1})} (Z^{-1}) \left[w(t) - \frac{G(Z^{-1})}{C(Z^{-1})X(Z^{-1})} \rho(t) \right] \quad (18)$$

The additional transfer function, Eq (19), was introduced in the control structure as shown in the block diagram of Fig (3) to counteract such change.

$$G_s(Z^{-1}) = Z^{-k} \frac{C(Z^{-1})Q(Z^{-1}) / F(Z^{-1})}{A(Z^{-1})} \quad (19)$$

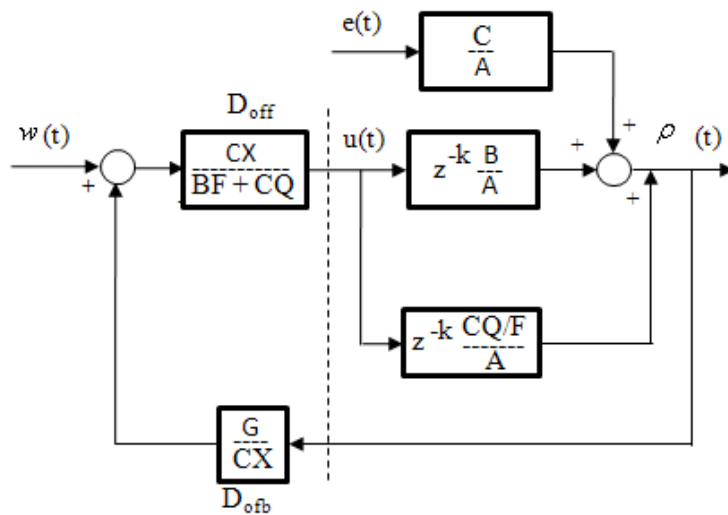

Figure 3 - Structure of the controller and plan change with DMV.

5. PROCEDURES FOR THE DESIGN OF DMV CONTROLLER WITH AMENDMENT

To obtain the control laws of the links X and Z of the manipulator robot to be implemented in Labview and Matlab computer program, was initially defined the structure of the plant obtained by the ARX model with two poles, one zero and a delay of transportation, as Eq (20). The following shows the equations used in the controller with a sub-index ρ which is equal to x for the direction of the X link and z for the direction of Z link. The structure defined for the plant.

$$\frac{\rho}{U} = Z^{-k} \frac{B(Z^{-1})}{A(Z^{-1})} = \frac{Z^{-1}(b_{0\rho} + b_{1\rho}Z^{-1})}{(1 + a_{1\rho}Z^{-1} + a_{2\rho}Z^{-2})} \quad (20)$$

From Eq. (20) we have:

$$\frac{\rho}{U} = \frac{b_{1\rho}Z^{-1} + b_{2\rho}Z^{-2}}{1 + a_{1\rho}Z^{-1} + a_{2\rho}Z^{-2}} \quad (21)$$

Considering the structure of the model defined for each manipulator robot link, it follows that:

$$C_p(Z^{-1}) = 1 ; n_{c_p} = 0 \tag{22}$$

$$A_p(Z^{-1}) = 1 + a_{1p}Z^{-1} + a_{2p}Z^{-2} \tag{23}$$

$$B_p(Z^{-1}) = b_{0p} + b_{1p}Z^{-1} \tag{24}$$

$$F_p(Z^{-1}) = 1 \tag{25}$$

$$G_p(Z^{-1}) = g_{0p} + g_{1p}Z^{-1} \tag{26}$$

Replacing the equations (22), (25) and (26) in (10), it follows that:

$$g_{0p} = -a_{1p} \tag{27}$$

$$g_{1p} = -a_{2p} \tag{28}$$

Replacing the equations (22), (24), (25) e (26) in (16), you get the DMV control law according to Eq.(29).

$$u_p(t) = \frac{1-p_p}{1-p_pZ^{-1}} \left[\frac{w(t) - \frac{g_{0p} + g_{1p}pZ^{-1}}{1-p_p} \rho(t)}{1-p_pZ^{-1}} \right] \tag{29}$$

Considering now the polynomial $Q(Z^{-1})$, of the project as given below:

$$Q = q_{0p} + q_{1p}Z^{-1} \tag{30}$$

To choose the Q parameter, it was considered a study proposed by Vaz (1999). He mentions that the controller in Al-Chalabi and Khalil (1994) presents shortcomings related to the guarantee of null error in steady regime, between the output of the original process and the reference, when it assigns a constant, to the Q parameter. For the controller design under study, the deficiency was verified and for this reason, a first-order Q polynomial was adopted. For the tuning of the Q parameters of the project, the P parameters where pre-set and varied all the possible feasibilities for Q.

And, replacing the equations (22), (24), (25), (26) and (30) in (18), we obtain the control law of the DMV controller with amendment, as shown on Eq. (31).

$$u_p(t) = \frac{1-p_p}{(b_{0p} + b_{1p}Z^{-1}) + (q_{0p} + q_{1p}Z^{-1})} \left[\frac{w(t) - \frac{g_{0p} + g_{1p}Z^{-1}}{1-p_p} \rho(t)}{1-p_pZ^{-1}} \right] \tag{31}$$

In the first moments of the computer program operation, proportional controllers with gains $k_{p_x} = k_{p_z} = 0,4$ where used in order to partly estimate the plant and avoid an inadequate action of adaptive control since the parameters have values equal to zero. After this initial time was automatically activated adaptive controllers with weighting polynomials given in Tab.1, according to the laws given by Eq. (31).

Table 1- Represents the ponderation polynomials used in the adaptive controllers of the robot.

	LINK X	LINK Z
p	0,7	0,7
q_0	0,9	0,95
q_1	-0,1	-0,1

6. RESULTS

In the experiment we used a sampling time $T_s = 200$ ms, was considered: as a reference, three pulse sequences, zero initial values for the vectors of the parameters of the two links, forgetting factor $\lambda = 0,97$. As a performance specification for the two links of the manipulator robot, was fixed on a maximum overshoot of 15%, settling time of 10s and error in procedure $\pm 5\%$.

Figures 4 and 5 show the references and links in the responses of X and Z, respectively.

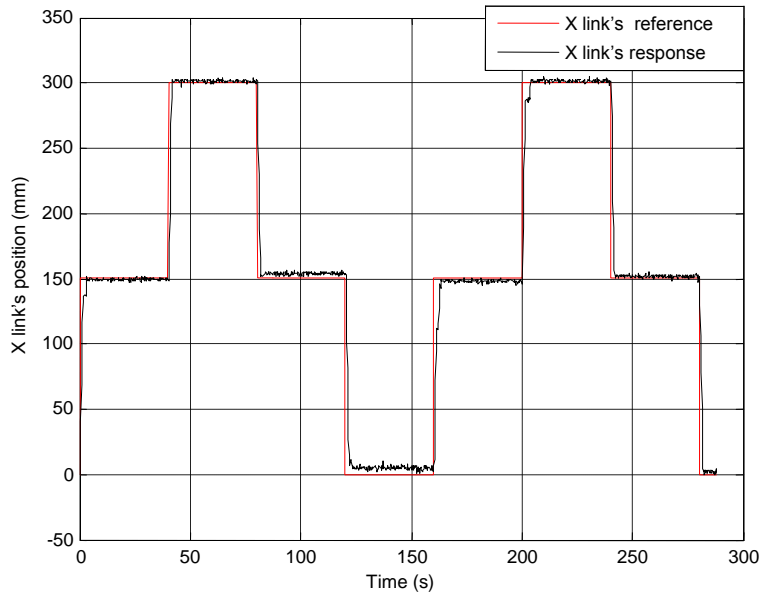

Figure 4 – Reference and response of the X manipulator robot's link, under the action of the DMV controller with change

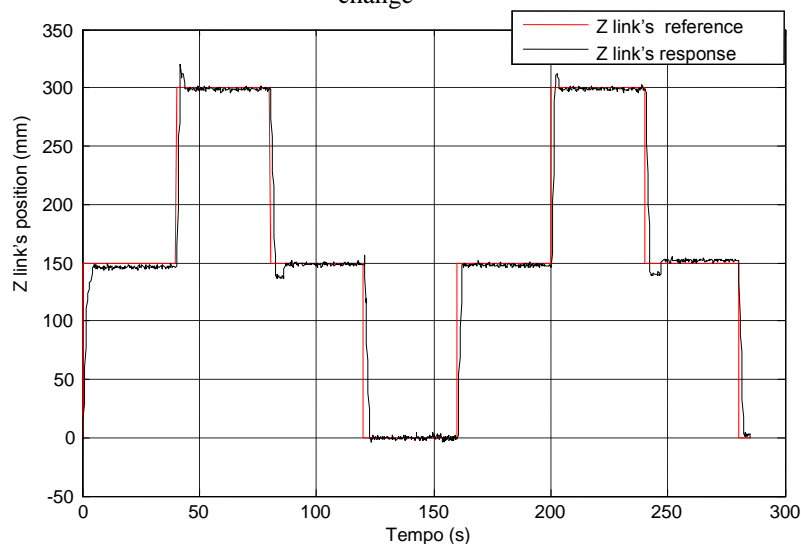

Figure 5 – Reference and response of the manipulator robot's Z link, under the action of DMV controller with change.

Table 2 and Table 3 show the performance of the links X and Z, under the action of the DMV controller, with change, following the references shown in Fig. 4 and Fig. 5, in the time intervals: from 0 to 40 s, 40 to 80 s, 80 to 120 s, 120 to 160 s, 200 to 240 s, 240 to 280 s and 280 to 285 s.

Table 2 – Represents the X link performance of the manipulator robot, related to the established performance specifications.

Time (s)	Reference (mm)	Error in Regime (%)	Settling Time (s)	Maximum Overshoot (%)
0-40	150	$\cong 2,00$	$\cong 3,0$	*
40-80	300	$\cong 2,66$	2,0	$\cong 1,6$
80-120	150	$\cong 4,00$	2,0	*
120-160	0	$\cong 5,00$	$\cong 3,5$	*
160-200	150	$\cong 4,00$	4	*
200-240	300	$\cong 3,33$	4	*
240-280	150	$\cong 3,33$	2	*
280-285	0	$\cong 2,73$	2	*

Table 3 – Shows the Z link performance of the manipulator robot, related to the established performance specifications

Time (s)	Reference (mm)	Error in Regime (%)	Settling Time (s)	Maximum Overshoot (%)
0-40	150	$\cong 4,00$	5	*
40-80	300	$\cong 2,66$	4	$\cong 13,3$
80-120	150	$\cong 3,33$	6	$\cong 9,33$
120-160	0	$\cong 2,66$	$\cong 3,0$	$\cong 2,66$
160-200	150	$\cong 2,66$	2	*
200-240	300	$\cong 3,33$	$\cong 4,0$	$\cong 7,33$
240-280	150	$\cong 2,00$	7	$\cong 8,00$
280-285	0	$\cong 2,66$	2	*

*Without overshoot

In Table 2 and Table 3, it is possible to verify that, in all the analyzed time intervals, the performance specifications imposed to the project, were respected.

The two valves of the electro-pneumatic manipulator have saturation in the ± 5 V points, with zero being in the midpoint. Figures (6) and (7) show the control variables of the links in the directions X and Z. It appears that there was no saturation of the control variables.

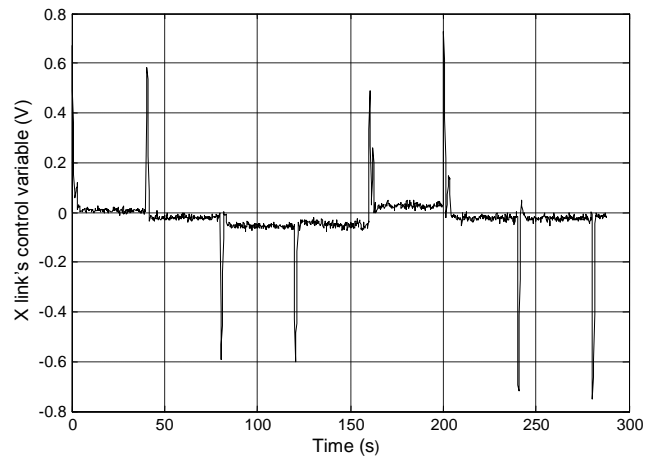

Figure 6– Control variable of manipulator robot's X link.

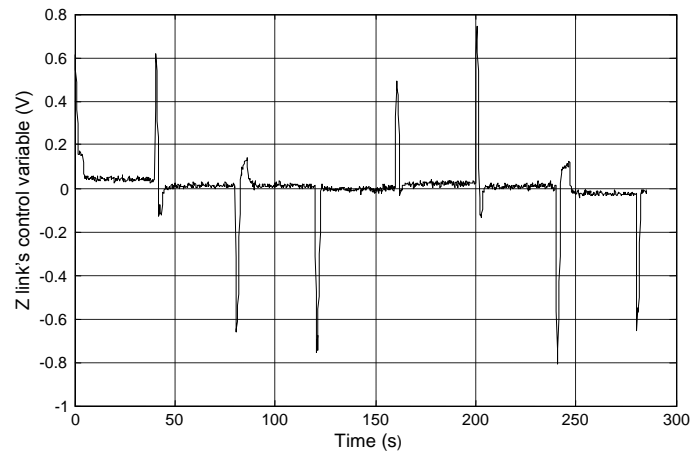

Figure 7 – Control variable of manipulator robot's Z link.

The Figures 8 and 9 shows a parameter evolution estimated in X and Z links.

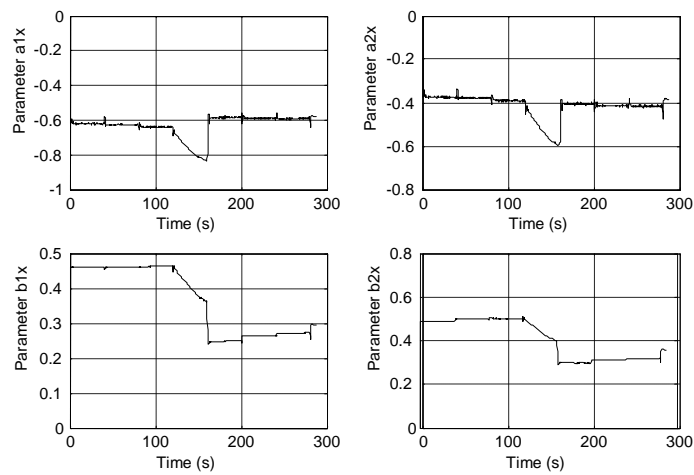

Figure 8 – Estimated parameters a_x and b_x , from X link of manipulator robot

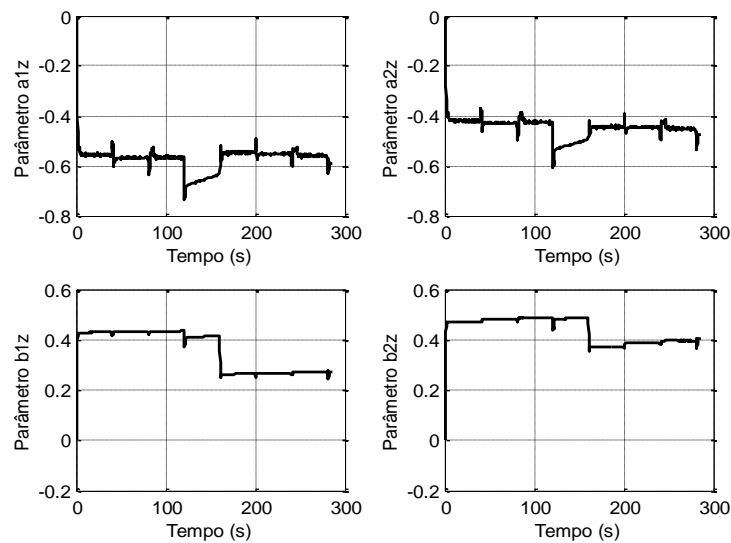

Figure 9 – Estimated parameters a_z and b_z , from Z link of manipulator robot

6. CONCLUDING REMARKS

This paper presented the design and implementation of DMV controllers in two links of a manipulator robot of three Cartesian DOF, driven by electro-pneumatic systems. The experimental results met the performance specifications imposed on the system, in other words, there was no overshoot above 15%, or error in procedure above 5%, just as there was no settling time greater than 10 s, which shows that the designed adaptive controllers were satisfactory for the monitoring references.

7. REFERENCES

- Aguirre, L. A., 2007a, *Enciclopédia de Automática: Controle & Automação*, volume II, 1º edição, Ed. Blucher, São-Paulo, Brasil.
- Aguirre, L.A., 2007b, *Introdução à Identificação de Sistemas: Técnicas lineares e não lineares aplicadas a sistemas reais*, 3º edição. Editora UFMG, Belo Horizonte/MG.
- Al-Chalabi, L.A.;Khalil, F.F.; 1994,*Dahlin Minimum Variance Self-Tuning Controller*, Int.J.of Control, 60(5).
- Aström, K. J. & Wittenmark, B., 1995, *Adaptive Control*. Ed. Addison Wesley Publishing, Segunda Edição.
- Coelho, A. A. R., Coelho, L. S., 2004, *Identificação de Sistemas Dinâmicos Lineares*, Editora da UFSC, Brasil.
- Isermann, R., Lachman, K. H., Matko, D., 1992, *Adaptive Control Systems*. U.S.A.: Prentice Hall.
- Khalil, F.F. 1992; *Dahlin Minimum Variance Self-Tuning Controller*.M.Sc.Thesis, University of Thecnology, Iraq.
- Ljung, L., 1999, *System Identification. Theory for the User., second edn*, Prentice Hall, Inc, Upper Saddle River, New Jersey.
- Vaz,G.L.F.,1999,*Controladores Adaptativos de Variância Mínima e Dahlin:Uma revisão e novas concepções de projeto*. Dissertação M.Sc.,UFSC,Florianópolis, SC,Brasil.
- Zafirov, E., Morari, M., Digital Controllers for SISO Systems: a Review and a New Algorithm. International Journal of Control, 42(4), 1985.