

COMPARISON OF ROBUST CONTROL TECHNIQUES FOR USE IN ACTIVE SUSPENSION SYSTEMS

Fábio Luis Marques dos Santos, fsantos@ita.br

Jorge Augusto de Bonfim Gripp, jorge.gripp@gmail.com

Alberto Adade Filho, adade@ita.br

Luiz Carlos Sandoval Góes, goes@ita.br

Instituto Tecnológico de Aeronáutica

Abstract. In this paper three robust control techniques are addressed - LQG/LTR control, H -infinity mixed sensitivity control and μ -synthesis control. These were designed to be used in an automotive active suspension system. The main goal is to obtain robust stability performance, in order to minimize the sprung mass (chassis) acceleration and to ensure road-holding characteristics. A nonlinear model a hydraulic actuator, in a half-car model, was used to verify the performance of each control technique. Comparison is then made, by means of numerical simulation, two types of road profiles.

Keywords: active suspension, robust control, LQG/LTR, μ synthesis, H -infinity

1. INTRODUCTION

The design of robust controllers for use in an active suspension system of a half-car is studied in this paper. The automotive suspension has a main goal of isolating the passengers inside the car, from road irregularities and other forces and disturbances such as those from cornering, accelerating and braking. At the same time, the suspension system is also expected to guarantee good road-handling performance for the vehicle. For long there have been studies on both industry and academia, to improve the suspension system performance. These studies have led to the active suspension systems. To better explain these systems, it can be easier to first introduce the so called passive systems.

Passive suspension systems are uncontrolled systems, built with only springs and dampers with unchangeable characteristics. This means that their parameters must be chosen adequately at project level to provide comfort and road handling while under different road conditions. This leads to a trade-off between road-handling and comfort, where improving one parameter can lead to the degradation of the other. This is a great motivation on the study of active suspension systems.

The active suspension systems normally use hydraulic actuators (see for example Fischer and Isermann (2004), Engelman and Rizzoni (2009), Williams (1997b) and Williams (1997a)), that can act directly on the vertical dynamics of the suspension, thus improving its performance.

This paper focuses on the design and comparison of robust control techniques applied to the active suspension problem. This sort of problem has been very well studied in the literature, see Palkovics *et al.* (2009) and Herrnberger *et al.* (2008). Three main robust control techniques are addressed in this work - LQG/LTR control, Mixed-sensitivity \mathcal{H}_∞ control and μ -synthesis control (for some practical examples, see Taghirad and Esmailzadeh (1998), Du *et al.* (2005) and Lauwerys *et al.* (2005)). A comparison is then made, by using singular values, structured singular values and temporal impulse response. Finally, the μ -synthesis technique is simulated using a non-linear actuator, and its performance is compared to that of a passive suspension system.

2. PROBLEM FORMULATION

The most commonly used models for the suspension control design is the quarter-car and the half-car models (see D. Karnopp (1974), Hrovat (1993) and all other references). In this paper, the half-car model was used and was taken from Canale *et al.* (2006); Milanese and Novara (2007). The half-car system (Figure 1) consists of an upper sprung mass M_s , with inertia J , that has two degrees-of-freedom (DOF), the pitch rotation θ and the vertical translation z . The sprung mass is connected to the front and rear suspension systems, that are modeled as a spring-damper system, with constant values $K_{f,r}$ and $\beta_{f,r}$ - the subscripts f and r shall be used therein to represent the front and rear parts of the system, respectively. The tires are modeled as a mass-spring system with stiffness K_w and mass M_w , adding another two DOF's to the system, zw_f and zw_r , representing the vertical movement of the tires. All the modeled masses in the system are considered plainly rigid, for sake of simplicity. The force inputs u_f and u_r represent the force exerted by the hydraulic actuators. The inputs zr_f and zr_r represent the road disturbance due to road irregularities and holes, V_h represents the vehicle horizontal traveling velocity, which is assumed constant for this model. Also, the parameters l_f and l_r represent the distance from the center of gravity (C.G.) to the front and rear suspensions, respectively. From the force equilibrium equations (see also Hrovat (1993); Krtolica and Hrovat (1992) for further details), the equations of

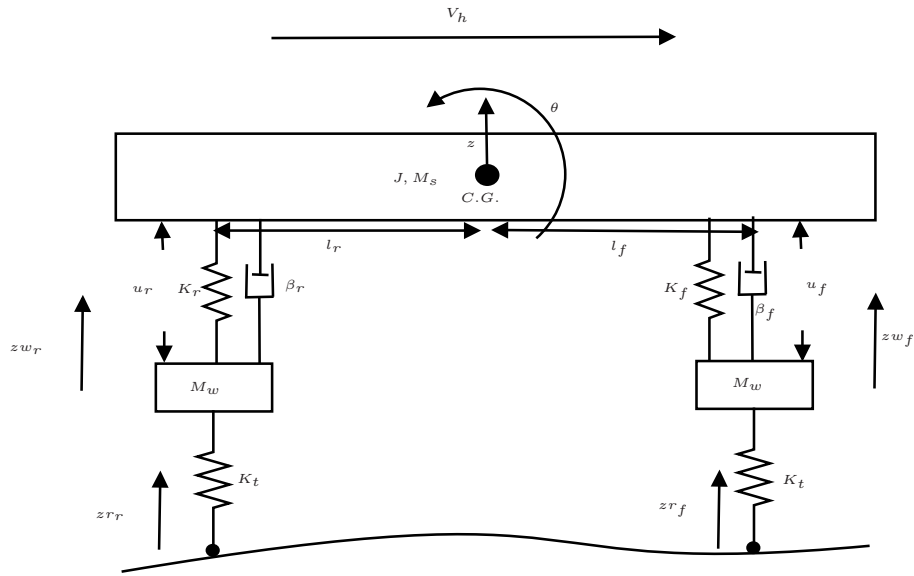

Figure 1. Half-car system schematics

motion describing the vertical dynamics of the half-car can be obtained (1), (2), (3) and (4).

$$\ddot{z} = -\frac{(K_f + K_r)}{M_s}z - \frac{(\beta_f + \beta_r)}{M_s}\dot{z} - \frac{(K_f l_f - K_r l_r)}{M_s}\theta - \frac{(\beta_f l_f - \beta_r l_r)}{M_s}\dot{\theta} + \frac{K_f}{M_s}z w_f + \frac{\beta_f}{M_s}\dot{z} w_f + \frac{K_r}{M_s}z w_r + \frac{\beta_r}{M_s}\dot{z} w_r + \frac{u_f}{M_s} + \frac{u_r}{M_s} \quad (1)$$

$$\ddot{\theta} = -\frac{(K_f l_f - K_r l_r)}{J}z - \frac{(\beta_f l_f - \beta_r l_r)}{J}\dot{z} - \frac{(K_f l_f^2 + K_r l_r^2)}{J}\theta - \frac{(\beta_f l_f^2 + \beta_r l_r^2)}{J}\dot{\theta} + \frac{K_f l_f}{J}z w_f + \frac{\beta_f l_f}{J}\dot{z} w_f - \frac{K_r l_r}{J}z w_r - \frac{\beta_r l_r}{J}\dot{z} w_r + \frac{l_f u_f}{J} - \frac{l_r u_r}{J} \quad (2)$$

$$z \ddot{w}_f = \frac{(K_f)}{M_w}z + \frac{(\beta_f)}{M_w}\dot{z} + \frac{(K_f l_f)}{M_w}\theta + \frac{\beta_f l_f}{M_w}\dot{\theta} - \frac{K_f + K_w}{M_w}z w_f - \frac{\beta_f}{M_w}\dot{z} w_f - \frac{u_f}{M_w} + z r_f \frac{K_w}{M_w} \quad (3)$$

$$z \ddot{w}_r = \frac{(K_r)}{M_w}z + \frac{(\beta_r)}{M_w}\dot{z} - \frac{(K_r l_r)}{M_w}\theta - \frac{\beta_r l_r}{M_w}\dot{\theta} - \frac{K_r + K_w}{M_w}z w_r - \frac{\beta_r}{M_w}\dot{z} w_r - \frac{u_r}{M_w} + z r_r \frac{K_w}{M_w} \quad (4)$$

The hydraulic actuator is also modeled to be incorporated into the half-car system and is described thoroughly in Engelman and Rizzoni (2009). It is a hydraulic actuator that uses a spool servo valve to control the oil flow to the piston. The actuator schematics can be seen on Figure 2. The flows Q_a and Q_b are considered to be equal, but on opposite directions, A_p is the piston area and P_s and P_r are the pressure from the pump and from the reservoir, respectively, and x_v is the spool valve displacement.

The linear actuator model also includes an electric model, used to move the spool valve up and down - acting directly

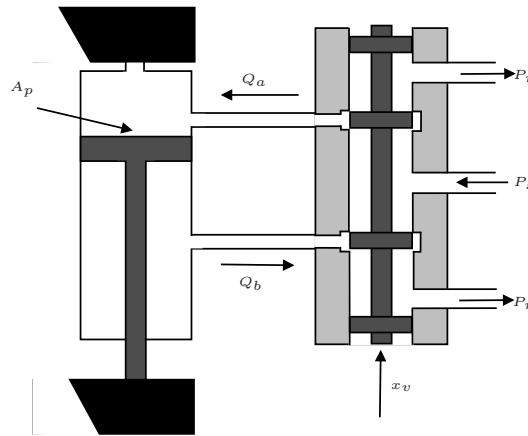

Figure 2. Hydraulic actuator schematics - piston and spool valve

on x_v .

$$\dot{P}_{Lf} = -\frac{4A_p\beta_e}{V_t}\dot{z} - \frac{A_p4\beta_e l_f}{V_t}\dot{\theta} + \frac{A_p4\beta_e}{V_t}z\dot{w}_f - K_c\frac{K_q4\beta_e}{V_t}x_v f \quad (5)$$

$$\dot{x}_v f = -\frac{1}{\tau_2}x_v f + \frac{\tau_1}{\tau_2}i_f \quad (6)$$

$$\dot{P}_{Lr} = -\frac{4A_p\beta_e}{V_t}\dot{z} + \frac{A_p4\beta_e l_r}{V_t}\dot{\theta} + \frac{A_p4\beta_e}{V_t}z\dot{w}_r - K_c\frac{K_q4\beta_e}{V_t}x_v r \quad (7)$$

$$\dot{x}_v r = -\frac{1}{\tau_2}x_v r + \frac{\tau_1}{\tau_2}i_r \quad (8)$$

Where $P_{Lf,r}$ is the load pressure, such that $A_p \cdot P_L$ equals to the force exerted by the actuator. The bulk modulus of the fluid is represented by β_e , the total fluid volume is V_t , K_q is the flow gain, K_c is the flow-pressure coefficient and τ_1 and τ_2 are the spool valve's gain and time constant, respectively.

3. CONTROL STRATEGIES

3.1 LQG/LTR Control

The LQG/LTR controller (Kwakernaak (1969), Skogestad and Postlethwaite (1996)), or Linear Quadratic Gaussian control with Loop Transfer Recovery, is a control design method that uses a classic LQG controller, and then applies a procedure to increase its robustness.

The classic LQG control problem consists on finding the optimal control input, $u(t)$, which minimizes (9).

$$J = E \left\{ \lim_{T \rightarrow \infty} \frac{1}{T} \int_0^T [x^T Q x + u^T R u] dt \right\} \quad (9)$$

where Q and R are the chosen constant weighting matrices. The solution to this problem is achieved by calculating the optimal controller by solving the Linear Quadratic Regulator Problem, and then designing a Kalman Filter that optimally estimates the system's states. Although both LQR and Kalman filter solutions yield good robustness properties to the controlled system, when used together on the LQG control, they do not guarantee any robustness properties. To recover the robustness properties inherent to the LQR system, a Loop Transfer Recovery procedure is carried. This procedure, which is thoroughly explained in Stein and Athans (1987), uses $Q = C^T C$ and $R = \rho I$ to obtain the controller, and as ρ tends to zero, the LQG loop transfer function tends to that of the LQR controller. On the other hand, as ρ gets smaller, high controller gains are introduced, which may cause problems with unmodelled dynamics, so the best solution is achieved on an iterative procedure, so that the gains are kept low.

3.2 Mixed-sensitivity \mathcal{H}_∞ Control

The Mixed-sensitivity \mathcal{H}_∞ control design consists of the design of the \mathcal{H}_∞ optimal controller while shaping the sensitivity function S , the closed loop transfer function KS and the complementary sensitivity function, T . The \mathcal{H}_∞ controller problem has the objective of minimizing the \mathcal{H}_∞ norm of the system, for a given performance vector. On the mixed sensitivity problem, this vector is composed of the sensitivity, complementary sensitivity and closed loop transfer function, multiplied by weights that are used to try to shape these functions as desired. The sensitivity function, $S(s)$ and the complementary sensitivity function, $T(s)$, of a given system plant $G(s)$ and its feedback controller $K(s)$, are represented in (10) and (11):

$$S = (I + G(s)K(s))^{-1} \tag{10}$$

$$T = (I + G(s)K(s))^{-1}G(s)K(s) \tag{11}$$

And the objective is to obtain a cost function given the weights W_P , W_U and W_T that shape S , KS and T respectively, while minimizing the system's \mathcal{H}_∞ norm (12).

$$\text{Minimize } \|T_{zw}\|_\infty = \begin{bmatrix} W_P S(s) \\ W_U K(s)S(s) \\ W_T T(s) \end{bmatrix} \tag{12}$$

3.3 μ -synthesis Control

The μ -synthesis controller (Skogestad and Postlethwaite (1996)) uses the $D - K$ iteration method (Gu *et al.* (2005)). The objective is to find a controller $K(s)$ such that the structured singular value of the system is minimized, where the structured singular value of a closed-loop system transfer matrix $M(s)$, with uncertainty Δ and singular values σ , is defined in equation (13).

$$\|M\|_\mu = \mu_\Delta^{-1}(M) := \min_{\Delta \in \Delta} \{\bar{\sigma}(\Delta) : \det(I - M\Delta) = 0\} \tag{13}$$

Given the closed-loop transfer matrix $M(s)$, represented by the system plant $G(s)$, uncertainty block $\Delta(s)$ and controller $K(s)$, as in Figure 3. Robust stability is achieved by guaranteeing $\|M_{dv}\|_\mu < 1$ and robust performance is achieved by guaranteeing $\|M\|_\mu < 1$.

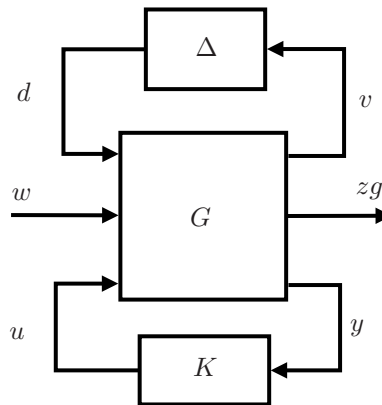

Figure 3. Block diagram representing system with controller and uncertainties

Usually, the design of robust controllers such as the μ -synthesis controller yield a very high order system (over 100 states), which is practically unfeasible on a real system. To make up for this problem, a model order reduction procedure is usually carried.

3.4 Performance Indexes

For the active suspension system in this paper, performance indexes are chosen such that the overall half-car dynamics are optimized. The performance vector zg , represented on (14) was chosen in a way to minimize vertical center of gravity displacement and velocity, as well as pitch angle and pitch velocity.

$$zg = [z \dot{z} \theta \dot{\theta}]^T \tag{14}$$

Table 1. Half car parameters

Parameter	Value
L_f	1.18 m
L_r	1.52 m
M_w	40 Kg
M_s	792.5 Kg
J	1328 Kg m^2
$K_{f,r}$	17200 N/m
$\beta_{f,r}$	2000 Ns/m
K_w	200000 N/m

The disturbance vector $w = [zr_f zr_r]^T$ represents the road irregularities and the control measurements and inputs were $y = [\ddot{z} \dot{\theta} P_{L_f} P_{L_r} z w_f z w_r]^T$ and $u = [i_f i_r]^T$, respectively.

3.5 Uncertainty Modeling and Robustness Analysis

To ensure the active system is stable and has reasonable robust performance, the half-car system was modeled with parametric uncertainty. These also represent possible system variations, such as vehicle load changes, tire pressure variations and wear and tear. The parameter G_a represents a gain uncertainty on the control input, as a way to make the system more robust to the non-linearities of the actuator.

$$M_s = \overline{M}_s(1 + \delta_{M_s}), \delta_{M_s} = 0.2 \quad (15)$$

$$J = \overline{J}(1 + \delta_J), \delta_J = 0.05 \quad (16)$$

$$K_f = \overline{K}_f(1 + \delta_{K_f}), \delta_{K_f} = 0.1 \quad (17)$$

$$K_r = \overline{K}_r(1 + \delta_{K_r}), \delta_{K_r} = 0.1 \quad (18)$$

$$K_w = \overline{K}_w(1 + \delta_{K_w}), \delta_{K_w} = 0.15 \quad (19)$$

$$G_a = \overline{1}(1 + \delta_{G_a}), \delta_{G_a} = 0.15 \quad (20)$$

To verify the robust stability due to the uncertainties, structured singular value analysis (or μ analysis) will be used. The μ analysis can be very useful to determine system robustness when dealing with parametric uncertainties. Given a diagonal set of uncertainties $\Delta = \text{diag} \{ \Delta_1, \dots, \Delta_n \}$, the structured singular value can be defined as (21):

$$\mu_{\Delta}^{-1} = \min_{\Delta \in \Delta} \{ \overline{\sigma}(\Delta) : \det(I - \Delta M) = 0 \} \quad (21)$$

Where M is a transfer matrix and $\overline{\sigma}$ is its upper singular value. Considering a feedback system $M(s)$, the robust stability conditions is that $\mu_{\Delta} \leq 1$. This means that, to obtain robust stability to the structured uncertainty Δ , the SSV of the closed loop system must be smaller than one for all frequencies. The robust stability problem can be turned into a robust performance problem by the introduction of an artificial uncertainty block Δ_p , related to the performance vector z , creating thus, a new uncertainty set $\hat{\Delta} = \text{diag} \{ \Delta_1, \dots, \Delta_n, \Delta_p \}$. If μ_{Δ, Δ_p} is less than one for all frequencies, than the system has robust performance.

4. SIMULATION AND RESULTS

The the half-car system was modeled and the 3 controllers, LQG/LTR, Mixed-sensitivity \mathcal{H}_{∞} and μ synthesis, were designed using MATLAB. The numerical values for the half-car system and hydraulic piston can be seen on Tables 1 and 2. One important aspect of the system concerns its response in relation to the road disturbances. On Figure 4, the singular values of the plant with the uncertainties are shown, using only the disturbance as inputs.

Table 2. Hydraulic piston parameters

Parameter	Value
K_q	0.923 m ² /s
τ_1	1.73 m/A
τ_2	0.03 s
β_e	1.6 · 10 ⁶ N/m ²
K_c	0
C_t	0
P_s	10000000
Piston area	0.0011 m ²
V_t	1.1 · 10 ⁻⁴ m ³

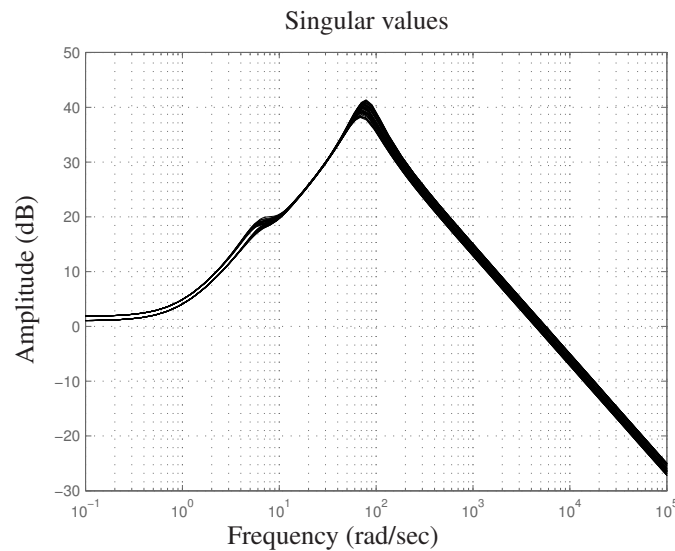

Figure 4. Singular values of the plant with the only the disturbance (road) inputs

4.1 Performance parameters

There are many alternatives to evaluate the performance of an active suspension system (see Savaresi *et al.* (2003) and Karnopp (1995)). For this paper, the structured singular value analysis (Doyle (1985)) will be used to determine robust stability and performance of the systems, then a time-based simulation using a non-linear model of the actuator will be carried with the most efficient control strategy, and 4 system states will be visualized (θ , $\dot{\theta}$, z and \dot{z}).

4.2 Controller design

The LQG/LTR control was carried using the `lqr` function from MATLAB. This function aids in the recovery of the robustness of the LQG system, by allowing different values of ρ to be used and compared with the LQR system. By using the function, the value of $\rho = 10^{-6}$ was chosen as the most suitable, meaning that the singular values of the LQG/LTR system were close enough to those of the LQR system, and also ρ was not too small as to produce unsatisfactory high gains.

The Mixed-sensitivity \mathcal{H}_∞ controller was designed using weighting functions to give the system disturbance rejection and robust stability. Two weighting functions, W_P and W_T were used, and the performance requirements for the controller are shown in (22).

$$\|T_{zw}\|_\infty = \left\| \begin{bmatrix} W_P S(s) \\ W_T T(s) \end{bmatrix} \right\|_\infty \tag{22}$$

Where $\|T_{zw}\|_\infty$ is the closed-loop transfer function from the road disturbances to the performance output, $S(s)$ is the sensitivity function and $T(s)$ is the complementary sensitivity function. The weighting functions used are shown in (23) and (24).

$$W_P = \frac{6.25 \cdot 10^{-7} (s + 112.5)^4}{(s + 0.05623)^4} \cdot [1, 1, 1, 1, 1, 1, 1, 1, 0, 0] \quad (23)$$

$$W_T = 10000 \frac{(s + 0.0001)^4}{(s + 3.162)^4} \cdot [1, 1, 1, 1, 1, 1, 1, 1, 0, 0] \quad (24)$$

The μ synthesis controller was designed using a D-K iteration algorithm provided by MATLAB. The algorithm uses the system plant modeled with parametric uncertainty. The algorithm is slow and does not guarantee convergence, specially in the case of large MIMO systems. Also, this method usually yields high order controllers, so a order reducing method was applied afterwards, to reduce the order of the system. The final controller referred hereafter as the μ synthesis controller is a reduced order controller, of 12^{th} order (24 states).

The 3 controllers were designed and simulated using the linear half-car plant with the actuator, including the parametric uncertainties. The singular values for the 3 systems were plotted on Figure 5

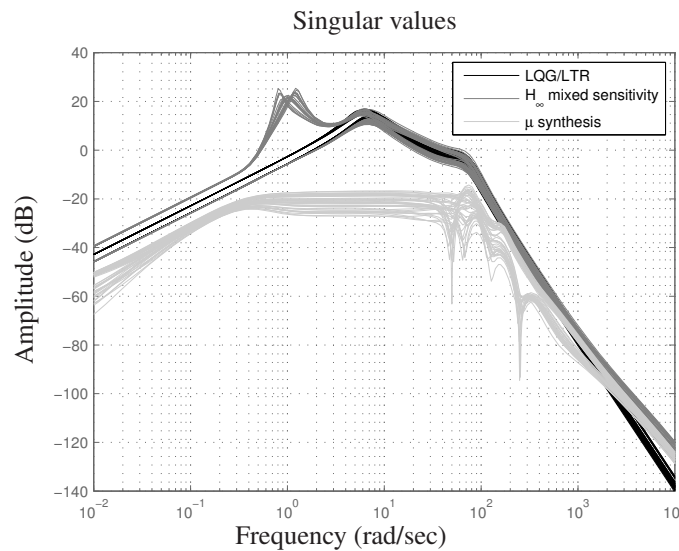

Figure 5. Singular values of the closed loop system for the 3 control techniques with uncertainties

The structured singular values for the three systems, regarding the structured uncertainty described in Section 3.5, were obtained and plotted on Figure 6. These values help determining the robust stability of the systems. It can be seen that the robust stability conditions ($\mu_{\Delta} \leq 1$ (0dB)) is satisfied for all systems and for the whole frequency range.

To verify the robust performance of the systems, an artificial uncertainty block Δ_p related to the performance vector z is added, thus creating a larger set of uncertainties. The structured singular values of the system for this new set (μ_{Δ, Δ_p}) was also calculated, and is shown on Figure 7. In this case, the only system that satisfies robust performance is the μ synthesis controller system.

Finally, a non-linear model of the actuator, obtained in Engelman and Rizzoni (2009) was implemented using Simulink, and the μ synthesis control was tested using the non-linear actuator and compared with an uncontrolled (passive) system. An impulsive road profile was used, with an amplitude of 0.1 meters and a horizontal velocity of 60 Km/h is assumed, and the simulation was carried for 9 seconds. The responses for θ , $\dot{\theta}$, z and \dot{z} are shown on Figures 8(a), 8(b), 9(a) and 9(b), respectively. On Figure 10, the front and rear actuator forces and driving currents are shown.

5. CONCLUSION AND RESULTS ANALYSIS

Three robust control techniques, LQG/LTR, Mixed-sensitivity \mathcal{H}_{∞} and μ synthesis, were investigated and designed for use in an automotive active suspension system, represented using a half-car model and a hydraulic actuator model.

The LQG/LTR control was the simplest controller designed. Its design is basically straight forward, with few parameters to be chosen. However, this simplicity also means that there is less improvement margin for the controller - not much can be done if it does not satisfy the robustness requirements.

On the other hand, the Mixed-sensitivity \mathcal{H}_{∞} was the most complex to be designed. The choice of the weighting functions is a very complex and delicate procedure, specially in a MIMO system with so many inputs and outputs. The

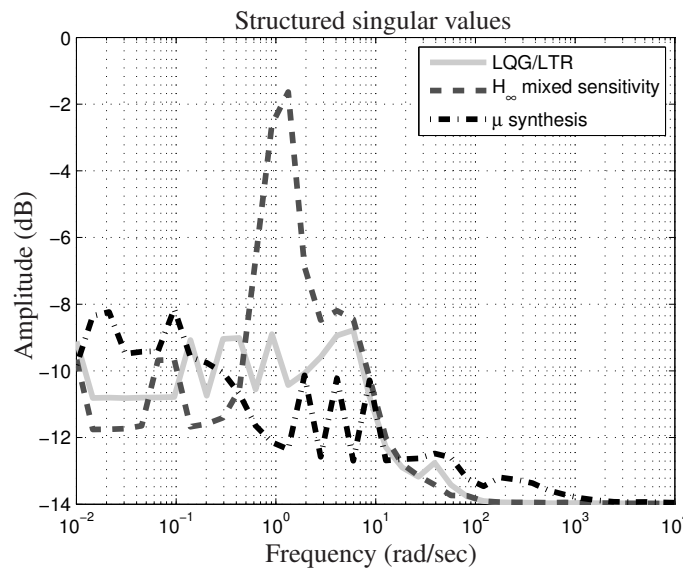

Figure 6. Structured singular values for the 3 controlled systems

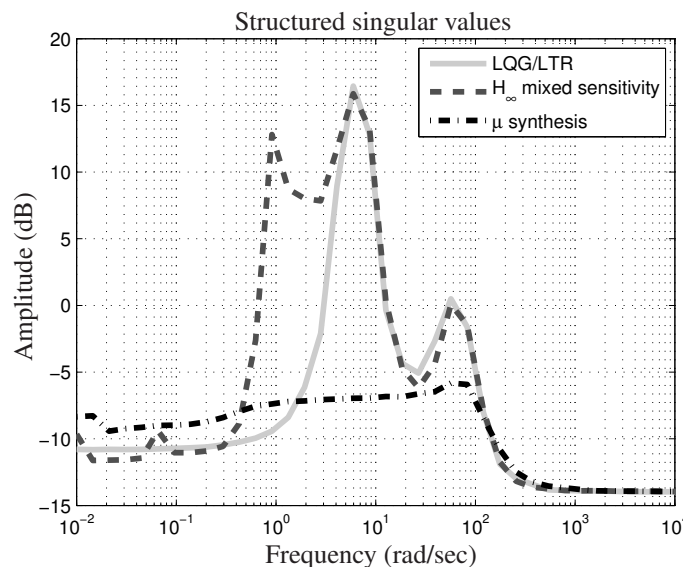

Figure 7. Structured singular values for the 3 controlled systems including artificial uncertainty block

choice of the weights can easily lead to low performance or unfeasible controllers. This also means that there is great margin for improvement, by changing the weighting functions.

The μ synthesis controller had the best performance overall. The feedback system achieved robust stability and performance, and the controller worked well when used with the non-linear system. Its performance was improved when compared to a passive (uncontrolled) system, with much reduced amplitudes and stabilization times. It is also important to note that even though the actuator forces and piloting currents were not chosen to be minimized, they were kept at relatively low levels at all times.

The D-K iteration method for finding μ synthesis controller takes a great deal of calculation time, specially for high order systems, and it does not guarantee that a feasible controller is found. Also, the resulting controller is usually of very high order, requiring a order reduction technique to render it usable. The μ synthesis controller design also allows the use of weighting functions, to help achieve more specific performance requirements. This procedure was not used in this work, as the use of the weight functions can greatly increase the order of the system, which would then lead to even higher calculation times and even higher order controllers.

6. ACKNOWLEDGEMENTS

The authors would like to thank the CAPES and CNPq agencies for promoting and supporting this research.

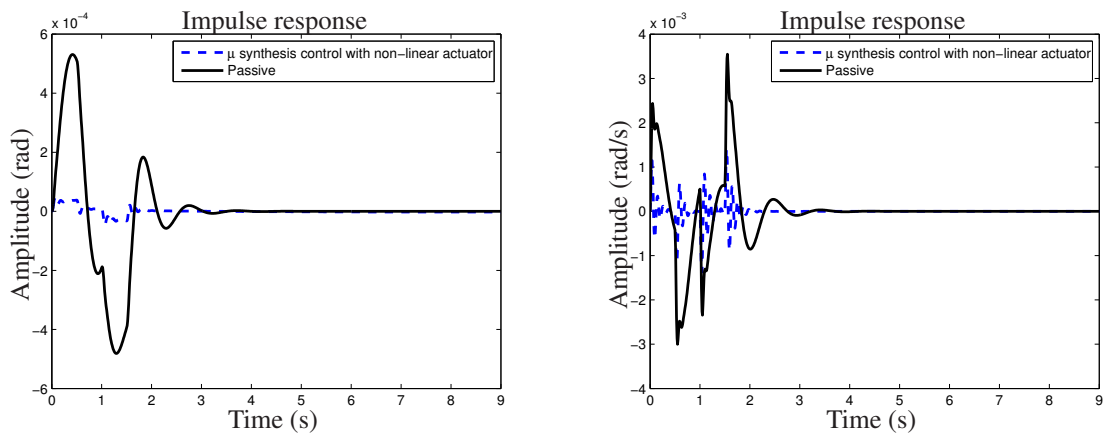

(a) Impulse response of the pitch angle θ - comparison between μ synthesis control using non-linear actuator and passive system (b) Impulse response of the pitch velocity $\dot{\theta}$ - comparison between μ synthesis control using non-linear actuator and passive system

Figure 8. Impulse response of the pitch angle and velocity for active and passive systems

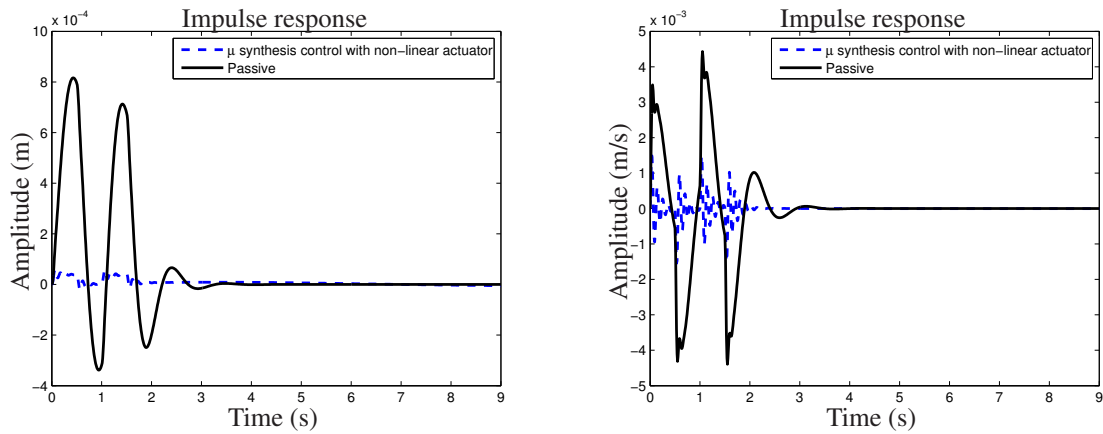

(a) Impulse response of the C.G vertical displacement z - comparison between μ synthesis control using non-linear actuator and passive system (b) Impulse response of the C.G vertical velocity \dot{z} - comparison between μ synthesis control using non-linear actuator and passive system

Figure 9. Impulse response of the center of gravity displacement and velocity for the active and passive systems

7. REFERENCES

Canale, M., Milanese, M. and Novara, C., 2006. "Semi-active suspension control using fast model-predictive techniques". *Control Systems Technology, IEEE Transactions on*, Vol. 14, No. 6, pp. 1034–1046.

D. Karnopp, M.J. Crosby, R.H., 1974. "Vibration control using semi-active force generators". *ASME - Journal of Engineering for Industry*.

Doyle, J., 1985. "Structured uncertainty in control system design". In *Decision and Control, 1985 24th IEEE Conference on*. IEEE, Vol. 24, pp. 260–265.

Du, H., Sze, K.Y. and Lam, J., 2005. "Semi-active h-infinity control of vehicle suspension with magneto-rheological dampers". *Journal of Sound and Vibration*, Vol. 283, No. 3-5, pp. 981–996.

Engelman, G. and Rizzoni, G., 2009. "Including the force generation process in active suspension control formulation". In *American Control Conference, 1993*. IEEE, pp. 701–705.

Fischer, D. and Isermann, R., 2004. "Mechatronic semi-active and active vehicle suspensions". *Control Engineering Practice*, Vol. 12, No. 11, pp. 1353–1367.

Gu, D., Petkov, P. and Konstantinov, M., 2005. *Robust control design with MATLAB*. Springer Verlag.

Herrnberger, M., Mader, D. and Lohmann, B., 2008. "Linear Robust Control for a Nonlinear Active Suspension Model Considering Variable Payload". *Proceedings of the 17th IFAC World Congress (WC), Seoul, South Korea*.

Hrovat, D., 1993. "Applications of Optimal-control to Advanced Automotive Suspension Design". *Journal of Dynamic Systems Measurement and Control-Transactions of the ASME*, Vol. 115, No. 2B, pp. 328–342. ISSN 0022-0434.

Karnopp, D., 1995. "Active and Semiactive Vibration Isolation". *Journal of Mechanical Design*, Vol. 117, No. Sp. Iss. B,

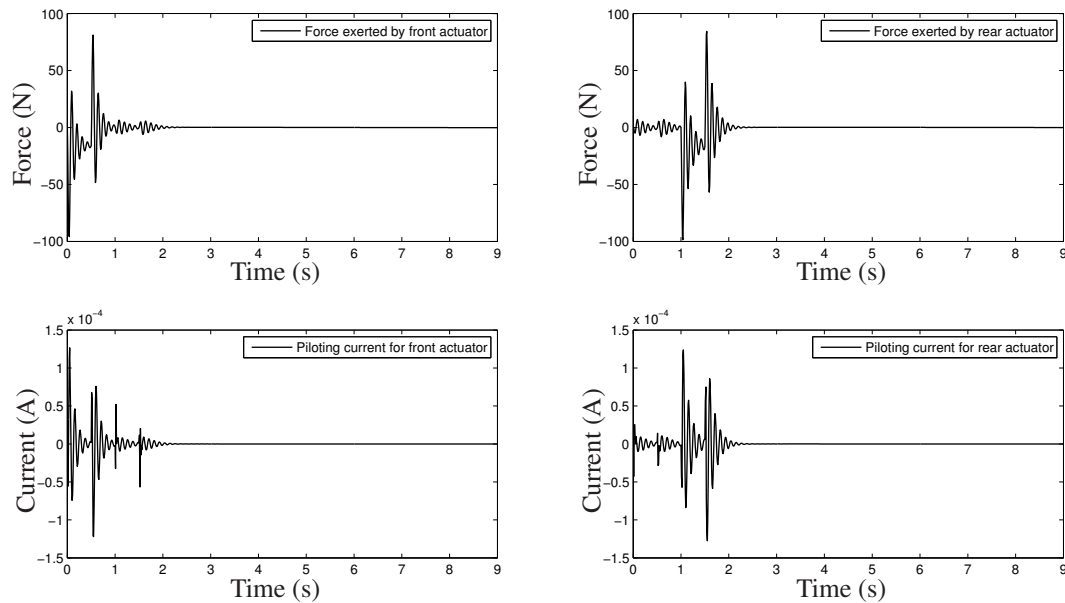

Figure 10. Front and rear actuator forces and driving currents

pp. 177–185. ISSN 1050-0472.

Krtolica, R. and Hrovat, D., 1992. “Optimal active suspension control based on a half-car model: an analytical solution”. *Automatic Control, IEEE Transactions on*, Vol. 37, No. 4, pp. 528–532.

Kwakernaak, H., 1969. “Optimal low-sensitivity linear feedback systems”. *Automatica*, Vol. 5, No. 3, pp. 279–285. ISSN 0005-1098.

Lauwerys, C., Swevers, J. and Sas, P., 2005. “Robust linear control of an active suspension on a quarter car test-rig”. *Control Engineering Practice*, Vol. 13, No. 5, pp. 577–586.

Milanese, M. and Novara, C., 2007. “Structured Set Membership identification of nonlinear systems with application to vehicles with controlled suspension”. *Control Engineering Practice*, Vol. 15, No. 1, pp. 1–16.

Palkovics, L., Gaspar, P. and Bokor, J., 2009. “Design of active suspension system in the presence of physical parametric uncertainties”. In *American Control Conference, 1993*. IEEE, pp. 696–700. ISBN 0780308603.

Savaresi, S., Silani, E., Bittanti, S. and Porciani, N., 2003. “On performance evaluation methods and control strategies for semi-active suspension systems”. *Decision and Control, 2003. Proceedings. 42nd IEEE Conference on*, Vol. 3, pp. 2264–2269 Vol.3.

Skogestad, S. and Postlethwaite, I., 1996. *Multivariable feedback control: analysis and design*. Wiley New York.

Stein, G. and Athans, M., 1987. “The LQG/LTR procedure for multivariable feedback control design”. *Automatic Control, IEEE Transactions on*, Vol. 32, No. 2, pp. 105–114. ISSN 0018-9286.

Taghirad, H. and Esmailzadeh, E., 1998. “Automobile passenger comfort assured through LQG/LQR active suspension”. *Journal of Vibration and Control*, Vol. 4, No. 5, pp. 603–618. ISSN 1077-5463.

Williams, R.A., 1997a. “Automotive active suspensions part 1: Basic principles”. *IMechE Proc. Part D*, vol. 211, pp. 415-426.

Williams, R.A., 1997b. “Automotive active suspensions part 2: Practical considerations”. *IMechE Proc. Part D*, vol. 211, pp. 427-444.

8. Responsibility notice

The author(s) is (are) the only responsible for the printed material included in this paper