

INTERDIGITATED CAPACITIVE SENSOR TO VERIFY THE QUALITY OF ETHANOL AUTOMOTIVE FUEL

Lucas Gonçalves Dias Mendonça

Department of Mechatronic and Mechanical Systems Engineering, Polytechnic School, University of Sao Paulo, Av. Prof. Mello Moraes 2231, CEP 05508-900, Sao Paulo – SP, Brazil.
lucas.mendonca@poli.usp.br

Delson Torikai

Department of Mechatronic and Mechanical Systems Engineering, Polytechnic School, University of Sao Paulo, Av. Prof. Mello Moraes 2231, CEP 05508-900, Sao Paulo – SP, Brazil.
delson.torikai@poli.usp.br

Ricardo Cury Ibrahim

Department of Mechatronic and Mechanical Systems Engineering, Polytechnic School, University of Sao Paulo, Av. Prof. Mello Moraes 2231, CEP 05508-900, Sao Paulo – SP, Brazil.
rci@usp.br

Eliphias Wagner Simoes

Laboratory of Integrated Systems, Polytechnic School - University of Sao Paulo, Av. Prof. Luciano Gualberto Trav.3 N.158, CEP 05508-900, Sao Paulo – SP, Brazil.
eliphias@lsi.usp.br

Nilton Itiro Morimoto

Laboratory of Integrated Systems, Polytechnic School - University of Sao Paulo, Av. Prof. Luciano Gualberto Trav.3 N.158, CEP 05508-900, Sao Paulo – SP, Brazil.
morimoto@lsi.usp.br

Abstract. *Ethanol obtained from sugar cane (Saccharum) has been used as automotive fuel in Brazil for decades. In spite of its undoubted success, several dishonest dealers sell fake mixtures that can cause serious damages to engines. Regular water (without any treatment) is the main additive used to adulterate the ethanol fuel sold at gas stations throughout Brazil. In a previous work we have demonstrated that interdigitated capacitive microsensors were able to distinguish different types of fuels based on the difference of their dielectric properties. The present work is focused on the use of improved versions of our microsensors for testing the quality of ethanol automotive fuel. This new generation of microsensors was designed to measure not only the capacitance; they can also promote some electrochemical reactions and are able to detect some physicochemical modifications that occur in the presence of alcohol, water and other solvents. Several samples have been prepared using conventional microfabrication techniques. Substrates of alumina and glass were utilized, while interdigitated structures were made of electroplated nickel or silver or nickel covered with gold. The interdigitated electrodes form hundreds of capacitors in parallel connection. The width of the grown electrodes is around 50µm, and the gap between electrodes is usually from 50µm to 100µm wide. The thickness of the interdigitated electrodes varies from 5µm to 30µm, depending on the metal used. Several characterizations were performed using an impedance analyzer, and the sensors were able to distinguish several types of adulterations.*

Keywords: *capacitive sensor, interdigitated, microsensor, IDT*

1. INTRODUCTION

Ethanol (ethyl alcohol), $\text{CH}_3\text{CH}_2\text{OH}$, is largely used in Brazil as an automotive biofuel since the 1970s and as a gasoline additive in an attempt at reducing petrol imports. In Brazil, it is obtained basically from the fermentation and subsequent distillation of sugar cane, and its production is regulated by a governmental agency, ANP (Brazilian National Agency of Petrol, Natural Gas and Biofuels). Hydrated ethanol (approximately 7% water volume) is obtained from distillation process and can be used directly on engines specially adapted for ethanol or in dual-fuel (flex-fuel) engines, which can use both ethanol and gasoline. On the other hand, anhydrous ethanol, obtained from further dehydration of distilled ethanol, is blended (roughly 20% in volume) to all gasoline fuel sold in Brazil.

Unfortunately, several dishonest dealers sell fake mixtures in disagreement with the regulations, which can cause serious damages to engines. The most common adulteration is to add extra water to hydrated ethanol; or the add extra anhydrous ethanol to the gasoline. In case of gasoline, other organic solvents have also been used for adulteration; some of them produces carcinogenic vapours.

Car manufacturers also suffer from this problem since they provide a minimum one-year warranty. So far, car manufacturers do not have the means to prove an engine damage was caused by adulterated fuel.

There are several techniques that can be used to verify the composition of both ethanol and gasoline. The Brazilian agency ANP elaborates and discloses several official methods used to inspect the quality of fuels sold at gas stations. These include measurement of density, infrared absorption spectrum, and physical chemistry analyses. However, most of the techniques are expensive, not portable and slow (Lima et al 2004, Santos et al 2003, Beckmann et al 1997, e Wang et al 2002).

In a previous work we have demonstrated that interdigitated capacitive microsensors were able to distinguish different types of fuels based on the difference of their dielectric properties (Mendonça and Ibrahim 2006).

This work presents an improved version of our relatively simple and inexpensive microsensor that evaluates the quality of both anhydrous and hydrated ethanol. The sensor is based on interdigitated structures serving as electrodes for a capacitor, with liquid ethanol as the dielectric. In addition, the sensor can also detect some chemical reactions based on the variation of the resistivity of the electrode. The configuration of the sensor can be seen in figure 1. The pair of pads A-B or B-C can be used to measure the impedance (or capacitance, or phase angle, or resistance) of the dielectric, while pair A-C can be used to measure the resistance between the extreme points of the same electrode. Nickel was chosen as the electrode material since it absorbs several types of atoms and molecules involved in the measurement. In addition, nickel is inexpensive and can be easily grown by an electroplating process.

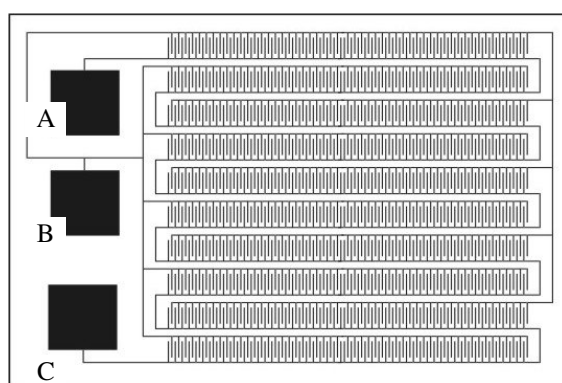

Figure 1. Layout of the sensor electrodes.

2. EXPERIMENTAL

2.1. Sensor Fabrication

Several prototypes were processed at the Microfabrication Laboratory of the Brazilian Synchrotron Light Laboratory (LNLS). The fabrication process needs only one mask since the electrodes are completely anchored to the substrate. Alumina square plates (2½") or glass square plates (5cm) were chosen as the substrates, Fig. 2(a).

The first step was the growth of a thin layer of titanium-gold film, deposited by sputtering, to be used as electrode for the subsequent electroplating process, Fig. 2(b). In the next step, the substrate was covered with photoresist SU-8 25 or AZ-4620 prior to the UV photolithography process, Fig. 2(c). The choice of the photoresist was adequate to mold the relatively high aspect ratio electrode structures. The mask pattern was transferred by UV exposure using a Karl Suss MJB3UV 300 equipment. Then, the samples were developed, figure 2(d), and prepared for the electroplating process.

Nickel was electroplated using an electrolyte solution consisting of 300g/l NiSO₄ + 60g/l NiCl₂ + 45 g/l H₃BO₃. A current density of 45mA/cm² was applied. Nickel electrodes as thick as 30µm, with gaps of 80µm or 100µm, with length of 800µm and width of 80µm could be obtained, Fig. 2(e). Then, the photoresist mold was removed using adequate solvent, Fig. 2(f). Finally, the bottom layer of titanium-gold film was removed from the exposed sites, Fig. 2(g) to avoid short-circuit.

2.2. Characterization

A Fluke PM6306 RCL meter with an accessory to measure DC resistance was used for the characterization of the samples, figure 3. Such instrument has a frequency range from 50Hz to 1MHz. The instrument was controlled using several computer programs. One of the programs was used to vary the amplitude and frequency of the AC applied measurement signal while measuring capacitance, phase angle and resistance between electrodes A-B or B-C (figure 1) at selected time periods. Another program could apply a DC bias while measuring the capacitance, phase angle and resistance. And another program could measure the DC resistance of a nickel electrode by connecting terminals A-C (Fig. 1) to the instrument.

The following materials were used:

- Anhydrous Ethanol P.A., 99.3° INPM - NBR 5991/97, from Synth
- De-ionized water

Samples were immersed in the following mixtures: a) anhydrous ethanol, b) ethanol + de-ionized water. Before the measurements, it was allowed a period of at least 15min for the mixture to homogenize.

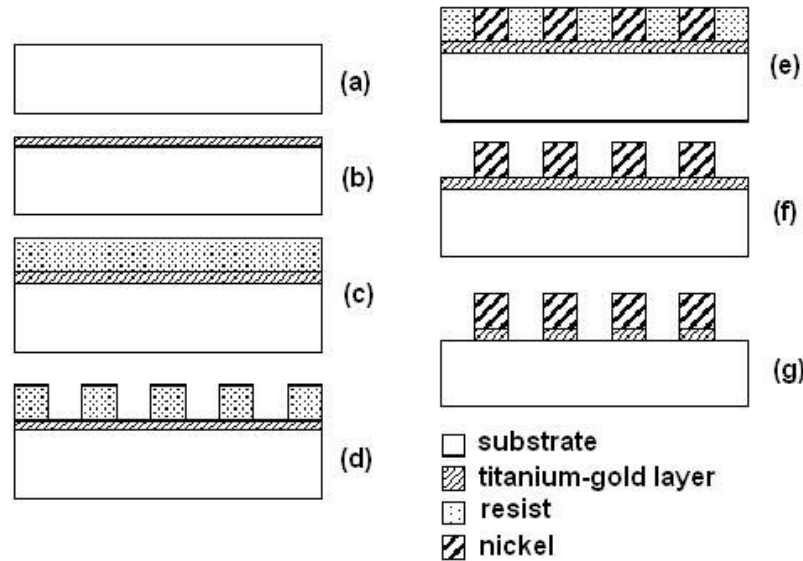

Figure 2. Microfabrication steps of the microsensor.

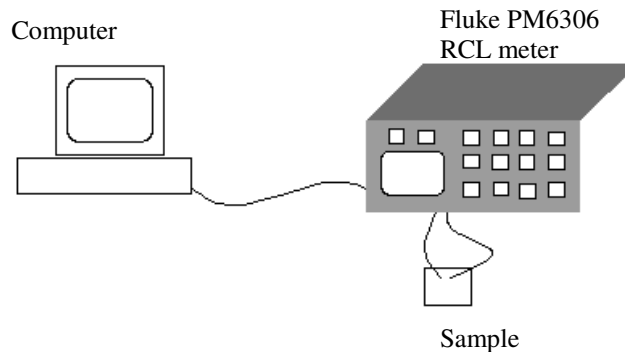

Figure 3. Configuration of the characterization procedure.

3. RESULTS AND DISCUSSIONS

Initially, the capacitance was measured for several mixtures of anhydrous ethanol + de-ionized water. The measurement was performed at uniform time intervals in order to observe possible variations. The results applying a measuring AC signal of 300mV at a frequency of 500kHz are shown in Fig. 4(a) for capacitance and in Fig. 4(b) for phase angle. It can be seen that different concentrations of de-ionized water are easily distinguished. Water has a dielectric constant higher than ethanol; therefore, an increase in water content also increases the measured capacitance of the mixture.

On the other hand, as the amount of water increases, the conductivity also increases because water usually contains dissociated ionic impurities or other types of particles (Gallagher 1975). Such increase in conductivity could be observed as a decrease in the resistance measured throughout the liquid mixtures using the electrodes A-B (Fig. 1). Figure 5(a) shows such behaviour for the mixtures considered here. Comparing the results of capacitance and resistance measurements, it can be concluded that both can be used to evaluate the amount of water in ethanol if the mixture contains only water and ethanol. However, it may be possible to elaborate another mixture with similar behaviour in order to cheat the sensor. Therefore, the measurement of an additional property is necessary.

Nickel and other elements of its group in the Periodic Table (palladium and platinum) are well known to absorb huge amounts of hydrogen atom in their crystalline structure, Lee 1996. Hence, it is possible to use nickel electrodes of our sensors to measure the amount of hydrogen in the mixture. The resistivity of nickel decreases with an increase of hydrogen atoms inside its structure.

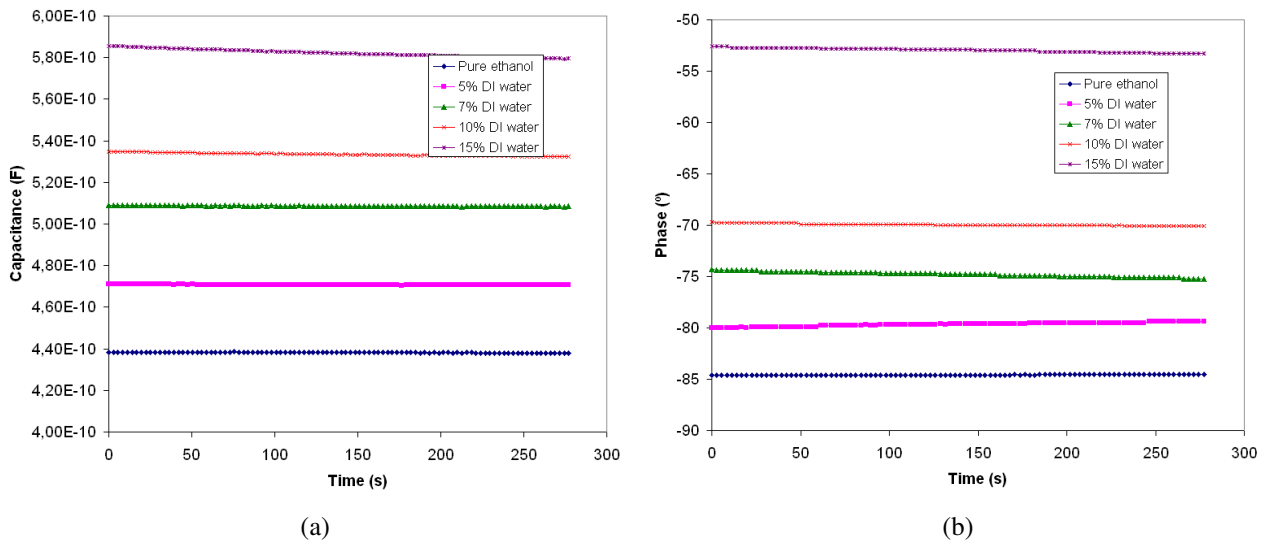

Figure 4. Capacitance (a) and phase angle (b) for different mixtures without applying DC bias.

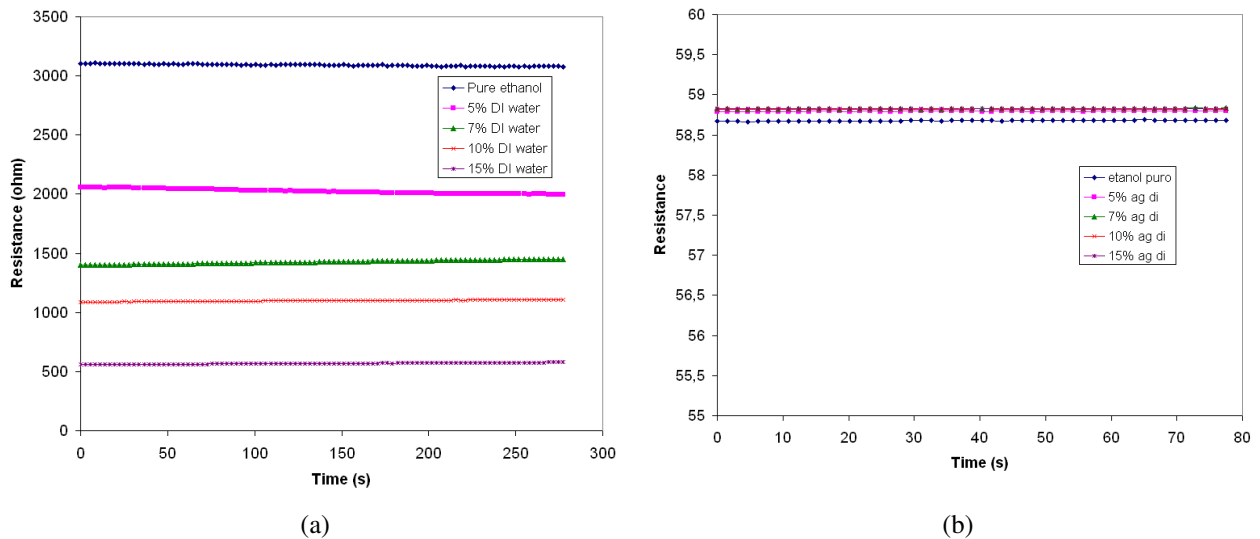

Figure 5. Resistance of the liquid dielectric (a), and resistance throughout a nickel electrode (b), without previous application of DC bias.

The hydrogen contained in water can be converted into hydrogen gas (H_2) by applying an electric voltage to force the electrolysis of water. Such electrochemical reaction can easily occur in our sensor by applying a DC bias since the gap between electrodes is just $100\mu m$. Such hydrogen can be absorbed by the electrode serving as the cathode.



In this way, application of a DC bias of 5V during the measurements of mixtures containing water was enough to produce H_2 to change the resistivity of the nickel electrode serving as the cathode. Figures 6(a) and (b) show, respectively, the capacitance and the phase angle variation with time for several mixtures measured at 500kHz, AC signal of 300mV, and DC bias of 5V.

Figure 7(a) shows that the resistance of the liquid contained between the electrodes kept the values measured before without bias (Fig. 5a). However, the resistance of the nickel electrode used as cathode (Fig. 7b) decreased considerably when compared to previous measurement without bias (Fig. 5b). Those results indicate that this improved version of our sensor cannot be easily cheated.

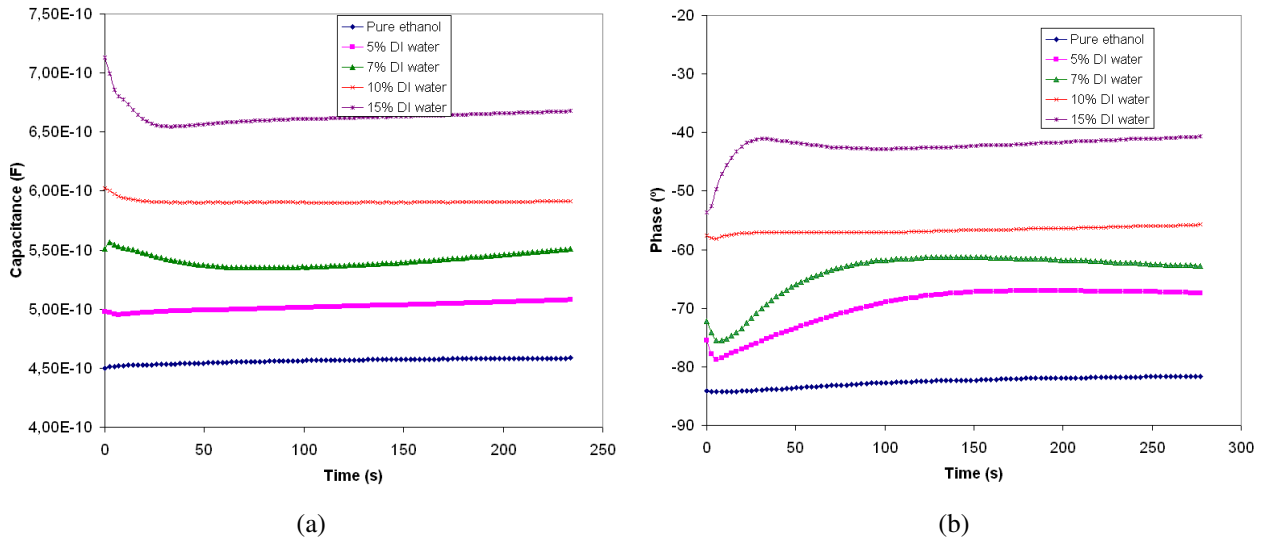

Figure 6. Capacitance (a) and phase angle (b) for different mixtures applying DC bias of 5V.

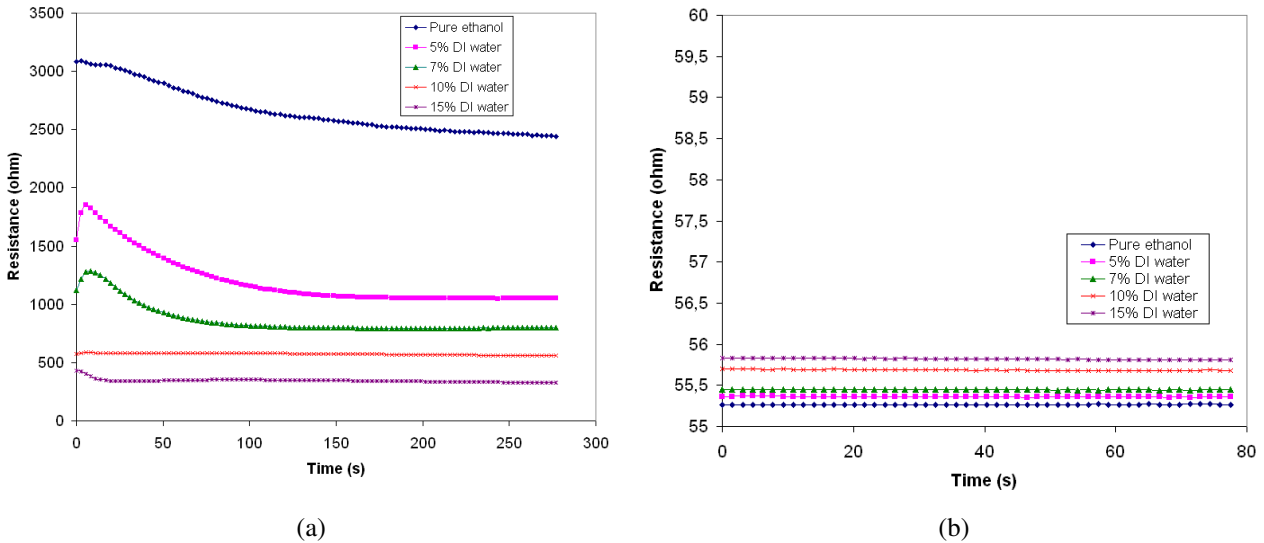

Figure 7. Resistance of the liquid dielectric (a), and resistance throughout a nickel electrode (b), after previous application of a DC bias of 5V.

4. CONCLUSIONS

These results show that our sensor can be very adequate to evaluate the quality of the fuel available at gas stations. The sensor can be placed near the entrance of fuel tank in order to quickly ascertain whether the fuel being filled is adequate or not.

Impedance bridge circuits to measure both capacitance and resistance are well known and can be easily miniaturized and integrated with an amplifier and a microprocessor unit to evaluate and save data for long periods.

5. ACKNOWLEDGEMENTS

Research supported by CNPq/CT-Petro 550467/2005-0 grants. LNLS – Brazilian Synchrotron Light Laboratory/LMF -Microfabrication Laboratory, where most prototypes were fabricated. LSI-EPUSP, fabrication and characterization laboratories.

6. REFERENCES

- Beckmann, F., et al, 1997, "Analysis of complex impedances in CMOS technology for chemical sensor applications", *Sensor and Actuators A* 62, pp 734-738.
- Gallagher, T. J., 1975, "Simple Dielectric Liquids", Clarendon Press – Oxford, London, UK.
- Lee, J. D., 1996, "Concise inorganic chemistry", Chapman & Hall, London, UK.
- Lima, J. A. P., et al, 2004, "Photothermal Detection of Adulterants in Automotive Fuels", *Anal. Chem.*, Vol. 76, pp. 114-119.
- Mendonça, L.G.D., Ibrahim, R.C., 2006, "Microsensor for the Measurement of Concentration of Liquid Solutions", *ECS Transactions*, Vol. 4 (1), The Electrochemical Society, USA, pp. 149-158.
- Santos, E. J., 2003, "Determination of ethanol content in gasoline: theory and experiment", *Proceedings SBMO/IEEE MTT-S IMOC*, pp. 349-353.
- Wang, Y. D., et al, 2002, "Mesostructured Tin Oxide as Sensitive Material for C₂H₅OH Sensor", *Talanta*, Vol. 57, pp. 875-882.