

RELIABILITY OF ELECTRO-HYDRAULIC EQUIPMENT: SYSTEMATIZATION AND ANALYSIS

Gilson S. Porciúncula

Universidade Federal de Santa Catarina – EMC - LASHIP
gilson@emc.ufsc.br

Victor J. De Negri

Universidade Federal de Santa Catarina – EMC - LASHIP
victor@emc.ufsc.br

Acires Dias

Universidade Federal de Santa Catarina - EMC - NEDIP
acires@emc.ufsc.br

Abstract. *This paper presents a process of systematization and analysis of the reliability parameters of a proportional hydraulic platform that aims to study position control using hydraulic systems.*

Currently the positioning systems using hydraulic circuits include mechanical and electronic components and software. These automatic systems involve diverse and complex technologies, for which reason the reliability analysis is difficult. Moreover, the failure modes which can occur in each item can produce distinct effects, increasing the complexity of this analysis.

The control of all parameters involved becomes very difficult for the design agents, with consequences for the other phases of the life cycle. In this regard a methodology to systemize the information necessary to obtain a product with reliability is proposed. In this process, hierarchic FTA and FMEA diagrams are used as tools for the systematization of the reliability parameters, and Petri Nets are used to represent the states and behavior of the automatic systems. The objective is to obtain the reliability parameters in a systematic and hierarchic form and their effects in system functions, facilitating their use by hydraulic system designers.

Keywords: *position control; reliability analysis; hydraulic systems.*

1. Introduction

Electro-Hydraulic Systems for Position Control (EHSPC) are used in some areas of application where it is necessary to modify an environment through controlled performance of the components or systems. These systems are a combination of mechanical and electronic components and, generally, they are controlled by software. The design of these kinds of automatic systems requires information from several areas of engineering. Consequently, it is very difficult to make decisions regarding the design tasks.

Adequate systematization of the knowledge used during the design phases of these systems can facilitate these tasks. Moreover, the complexity of these systems creates a very favorable environment for failure, which can reduce the reliability of the product during its life cycle.

The reliability of hydraulic systems should guarantee their primary functions, such as, force, speed, torsion, etc. It should also guarantee the secondary aspects, such as low operational and maintenance cost, accuracy and stability. It should further guarantee low risk, including personal safety, integrity of the environment and safety of the equipment and installations.

This paper presents a process of systematization and analysis of the reliability parameters for use during the design phase of automatic systems. We applied a case study of equipment called the Proportional Hydraulic Platform (PHP) - Demonstration Module.

This study is presented in 5 sections: firstly, some concepts of the EHSPC are defined; secondly, some tools of systematization for automatic systems and reliability analysis are presented; thirdly, a systematization proposal is presented; fourthly, the PHP - Demonstration Module is discussed; and fifthly, the results and conclusions of this study are related.

2. Electro-Hydraulic Systems for Position Control (EHSPC)

The EHSPC are used widely mainly in agricultural and industrial, aeronautical and hydroelectric installations, due to some advantages such as the versatility of their configuration, precision in their control of mechanical devices heavy and commanded by signals with low energy consumption.

The EHSPC are composed of a hydraulic circuit and a control loop, including a proportional directional valve, cylinder, position sensor and a controller.

Figure 1 shows the basic configuration of an EHSPC that has the following components:

- ⇒ V1 - proportional directional valve
- ⇒ A1- hydraulic cylinder
- ⇒ E1 – electronic processing (controller (Z1) and position sensor (S1))

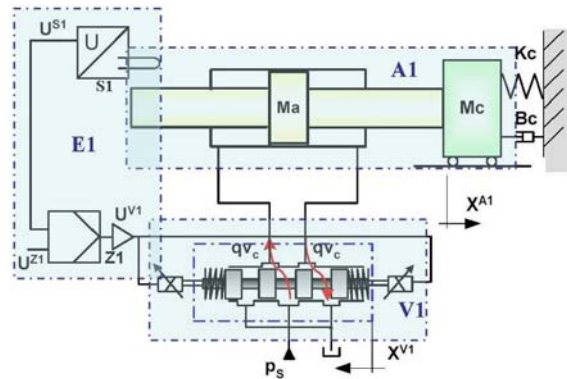

Figure 1 - Hydraulic system for position control

In accordance with De Negri (2001), the desired position for the cylinder is established by the reference voltage (U^{Z1}) which, through the controller, generates a command voltage (U^{V1}) in the proportional directional valve, producing the spool displacement. This provokes a flow through the valve and promotes a variation in the pressure in the cylinder chambers resulting in the movement of the mass (M) that is measured through the position sensor (S1) producing a voltage (U^{S1}). This voltage (U^{S1}), with a sign opposite to that of the reference voltage (U^{Z1}), provides the feedback on the position. On reaching the desired position, the command voltage of the valve (U^{V1}) will be annulled indicating that the position of the piston (X^{A1}) corresponds accurately to the desired position.

However, for this system to reach a desired position with accuracy and precision it is necessary to attend to some design requirements, such as, to keep a constant pressure in the feeding of the valve and to adequately compensate for the position error. In this case, besides the system being well sized, it needs to be monitored during its operation. Any external interference or wear of some item can cause the system to fail, provoking errors, such as instability, oscillations, slow reply, and others.

3. Systematization of the knowledge

In this section some tools used in the systematization of automatic systems and in the failure analysis are presented. The use of these tools aims to gather information about the product that is being developed in a systematic and hierarchic form, to assist in the decisions during the product life cycle, leading to a more reliable and safe product.

3.1. Automatic systems

The analysis of automatic systems design is not a very simple task, since the activities occur in different technological domains with the involvement of diverse experts. Questions regarding the designer's knowledge and experience and the availability of analysis and design tools are crucial to finding the best solution to the problem.

Automatic systems represent an adequate combination of the three areas: mechanics, software and electronics, conferring the following characteristics to a design, SOUZA (2005):

- ⇒ Simplification of the mechanical system;
- ⇒ Reduction development of time and cost;
- ⇒ Facilities to introduce modifications or new capacities;
- ⇒ Flexibility to receive future modifications or it receives new functionalities.

Automatic systems manipulate the information, energy and matter flow in a specific process with the intention of provoking a change in an environment, external to the system. In this context, De Negri (1996) has presented a system model using a Channel/Instance Petri Net (C/I Net), Fig. 2a. This modeling of an automatic system defines design parameters in a functional and structural form, which shows a structural vision of the system from the initial design phases.

The functional approach to automatic systems is defined by the different states of the system that the model can detect, according to the achievement degree of its functions. The structural approach is defined by the arrangement of its components and subsystems, during the process. This method also has the advantage of system modularization, which facilitates some aspects in terms of manufacture, assembly and maintenance. With the model deployment it is possible to have a better vision of the information energy and matter flow in the system. Fig. 5 shows this model for the proportional hydraulic platform.

The notation in C/I Net, argued in Heuser (1990 cited in De Negri, 1996) is a diagrammatic representation that uses

two basic elements: the active functional units (Instances), represented by rectangles, and the passive functional units (channel), represented by circles, where these two elements are linked through directed arcs.

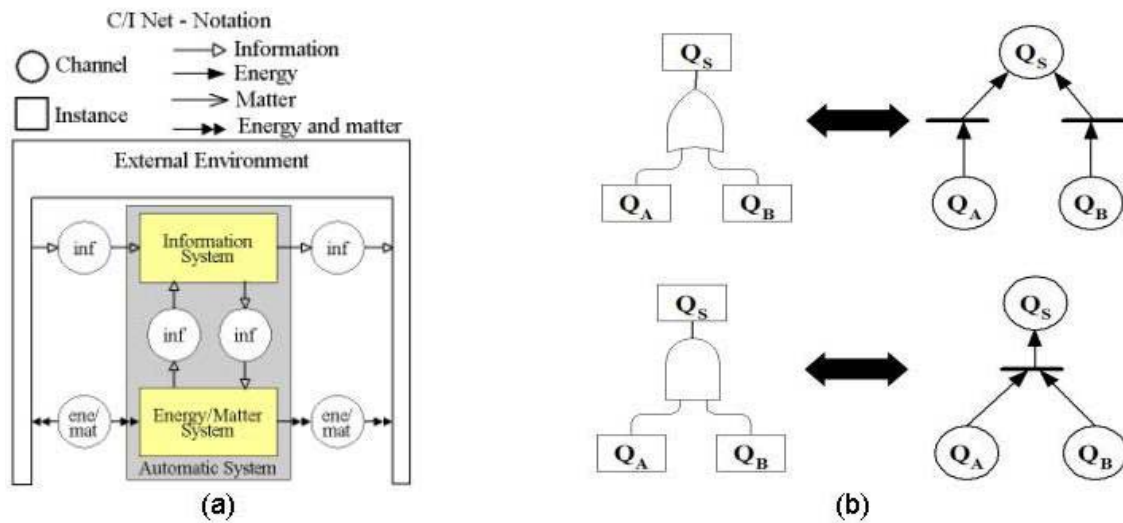

Figure 2 – (a) Model automatic system, DE NEGRI (1996); (b) FTA and Petri net

3.2. Failure analysis

The objective of the failure analysis methods is to add reliability and maintainability to the product. Reliability is the capacity of an item to execute a function under specified conditions, within a given time period. Maintainability is the capacity of an item to be retained in or restored to a condition needed to execute its required functions, under specified conditions, when the maintenance is executed under defined conditions and by means of procedures and prescribed methods, Dias (1997, cited in Sakurada (2001)).

According to Jingyi *et al.* (2001), the hydraulic components have a complex structure, and the study of their reliability is important for the analysis of all systems. Moreover, the use of electronic processing in hydraulic systems demands that greater attention be given to the reliability analysis of these systems. Therefore, systematization in the failure modes and the transmission relations of the failures to the rest of the system, among others aspects, can help in the design criteria, management and diagnostic of the failures in hydraulic systems.

FMEA (Failure Modes and Effect Analysis) and FTA (Fault Tree Analysis) are tools that assist in the analysis of system reliability. One of the parameters most used in system reliability analysis is the failure rate (λ). The failure rate represents the ratio between the failure occurrence and a determined time period. The variation in the failure rate during the life cycle depends on its characteristics; however, the failure rate curve, also known as the bathtub curve was idealized presenting three distinct periods during the life cycle.

The failure rate curve is represented by three characteristic periods: youth failures, which include, predominantly, design, transport and assembly failures; utilities failures where the failure rate is constant and the failures are random and happen due the overloads and; discarding failures that are due to wear and fatigue, where the failure rate tends to increase until the system is discarded. Good management of the reliability parameters in the design phase of the system would reduce the length of and the variation in the system youth phase, as would good management of the hydraulic system maintenance through monitoring its operational conditions, which can extend the period of utility, increasing the useful life of the system.

3.3. Petri Nets

The Petri net is another tool that has been used in system failures analysis. The Petri net is a graphical and mathematical tool that adapts well to a great number of applications where a knowledge of events and simultaneous evolution are important Cardoso and Valet (1997). Moreover, it presents a formalism that enables the analysis, evaluation and computational implementation of the system in the same model. In 2003, Riasco presented a methodology for failure analysis and treatment in automatic machines, using Petri nets, where only a structure model, a detention and treatment failure net and the normal machine process were developed.

Liu (1997) and Knezevic (2001), have proposed failure analysis methods based on Petri net models, which are being used in reliability analysis of complex systems and aiding in the computational implementation of systems. This tool has been shown to be adequate for the fault tree representations of automatic systems, for reliability calculation, definition of the reliability model and the minimal cut set for the system.

Figure 2b shows the basic relations between the fault tree and Petri net, where the probability for a S event to occur is calculate by Eq. (1) and Eq. (2) for the logic gates OR and AND. In the case of Eq. (1), the items are considered as

independent and not mutually exclusive, a characteristic prevailing in this paper.

$$Q_S = Q_A + Q_B - Q_A \cdot Q_B \quad (1)$$

$$Q_S = Q_A \cdot Q_B \quad (2)$$

where, Q_i is the probability for a i event to occur

4. Hydraulic systems failure analysis systematization

Reliability analysis of complex systems with multiple components must be carried out through modules, which facilitates the identification of the reliability parameters and their relations within the system. This modularization, according to Blischke and Murthy (2000), can be structuralized through levels and modules where each level can present many modules. In the case of hydraulic systems it is possible to observe this structure in the modeling as an automatic system, presented in Fig. 2a, where the first level of decomposition is found, which includes the Energy/Matter (hydraulic circuit) and Information subsystems.

The hydraulic circuit can still be divided in two modules, acting circuit and power unit, and the control system can supply the other system module. Depending on the complexity of the system under study the amount of subsystems and modules can be expanded until more adequate components, their reliability parameters and their relationships within the operational flow of the system are identified. The modeling of each separate module is not necessary since this is naturally achieved during the deployment of C/I Net model.

The achievement of function of each module, defines that the global function of the system was reached. The identification of the function fulfillment is an important factor to be defined; therefore this parameter can be presented in several forms and with different perceptions. This can be obtained through a range of acceptable values, some effect in the environment or another subsystem.

If a module does not attend the desired function, this means that some item is not fulfilling its elementary function, or is still inducing other items to enter into a failure state. The deployment of each module will assist in the identification of the potential item that is provoking some anomaly in the system. This deployment can be carried out through C/I Net concepts and be modeled to a fault tree in a Petri net, where the top event would be the non attended partial function.

The reliability of each module could be calculated from the Eq. (3), through the failure rate values of each item and their relationship structuralized by the fault tree of the module.

$$R(x) = e^{-\sum_{i=1}^n \lambda_i} \quad (3)$$

The system reliability will be calculated through Eq. (4). Where F_{Mi} is the unreliability of a Module, and the Eq. (5), where $R_S(x)$ is the system reliability. In accordance with the fault tree composed by the system modules and the unreliability of each module.

$$F_{(MA \cup MB)} = F_{MA} + F_{MB} - F_{MA} \cdot F_{MB} \quad (4)$$

$$R_S(x) = 1 - F_S(x) \quad (5)$$

The reliability can also be guaranteed from the analysis of the component and system failure modes. Diagram FMEA is used in the systematization of these data, this diagram together with the FTA can improve the system reliability. The failure modes distribution analysis of an item can also assist in the effect cause relation analysis of the system.

Table 1 briefly presents the tasks and tools required in use of this approach to analyzing automatic system reliability. In the next section these will be used in the case study of EHSPC.

5. Case Study - Proportional Hydraulic Platform - Demonstration module

The PHP - Demonstration module objective is to demonstrate the efficiency of the position control with a proportional hydraulic system, making it possible to confirm, in practice, some theoretical concepts of these hydraulic systems. The intention of the module is to capture spheres launched from an approximate height of 870 mm, from three different positions, through a basket that is connected to a cylinder rod. The spheres are set free by the action of solenoids that are in each magazine, and a cylinder should advance to a position that captures the falling sphere, Fig 3.

This module is constituted by an actuator hydraulic circuit, a control loop and a spheres module, whose function is to liberate the spheres from the magazine. The hydraulic circuit of this system is presented in Fig. 3.

Table 1 - Tasks and tools of automatic systems analysis

Stage	Task	Tool	Description
1	Design specifications	Design information	To define design specifications, such as product life cycle, global function, and input and output variables
2	System modeling	Channel/Instance Net	Structural and hierarchic functional modeling of the system
3	System modules	Channel/Instance Net and Petri nets	To define the modules and the structure and relation of these in the system
4	System module analysis	Petri nets	To define items of each module
5	Definition of failure rates	Petri net and database	To define the failure rate values for items of each module
6	Module reliability	Petri nets and reliability equations	Module Reliability calculation based on the failure rate of each item
7	System reliability	Petri nets and reliability equations	System Reliability calculation based on the unreliability of each module.
8	Failure mode identification	Database	Failure mode identification of each item.
9	Failure mode analysis	FMEA and database	Failure mode analysis and systematization and determination of its effect through the FMEA
10	Failure mode distribution	Database	To analyze the failure mode distribution of each item of system.

Figure 3a shows the electro-hydraulic circuit and positions P1, P2 and P3 of the spheres store. In this system, the user establishes the desired position of the sphere launching and the control system locates the cylinder piston in the capture position with accuracy, in accordance with the behavior described in section 2.

Figure 3b shows the user interface. The acquisition and handling of analogue and digital data used in the computer based digital controller, were carried out with a VXibus system and LabVIEW Software.

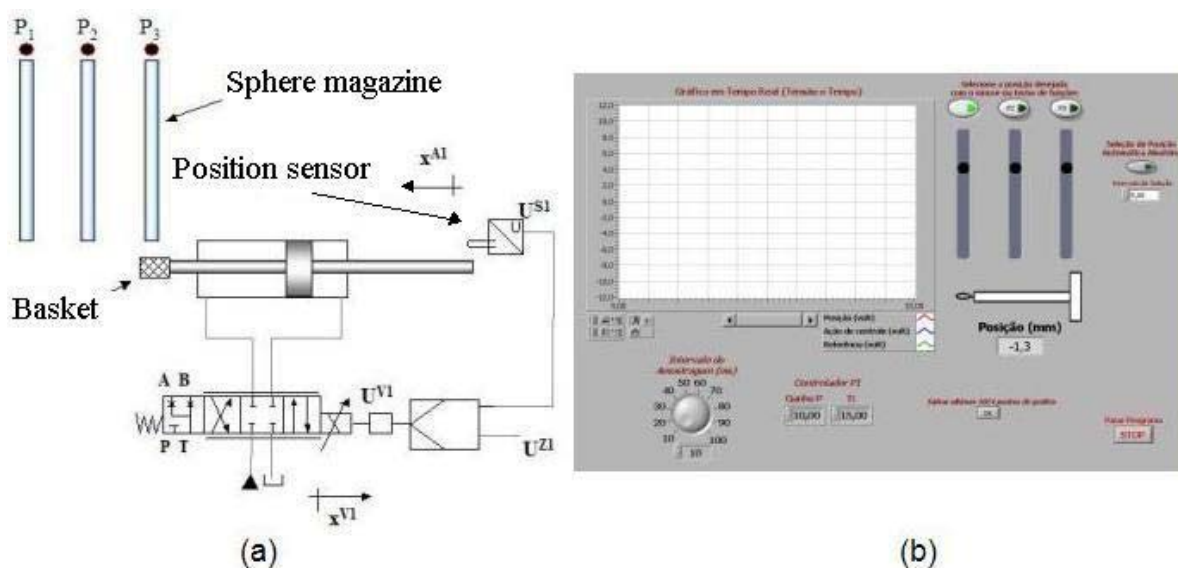

Figure 3 - PHP- Demonstration module Configurations: (a) Electro-hydraulic schema (b) user Interface

This system was developed in the Laboratory of Hydraulic and Pneumatic Systems- LASHIP of the Mechanical Engineering Department of Federal University Santa Catarina – UFSC, and is being used in the education of undergraduates and studies with graduate students, Fig. 4b.

Although this PHP - Demonstration module is a simple system composed of few items, it is complex enough to present items of different technological areas which are connected and communicating. Thus, the occurrence of a failure is inevitable during its useful life, and so this will be used as a case study for the approach proposed in this paper.

Firstly, the system was modeled with a C/I net, where it is possible to define the modules and the way they are related. The module architecture is presented in Fig. 5a. Figure 5b shows the information processing module deployed, identifying each item of this module. From this definition it is possible to treat each module separately, identifying and analyzing the reliability parameters of each one. In this paper an analysis of the power unit module will be presented. Figure 6b shows this module’s fault tree with the respective failure rates of each component.

The failure rates are expressed in accordance with Eq. (6), and these rates were taken from the RAC (Reliability Analysis Center, 1999) database. Thus, they are theoretical values, and do not take into account specific characteristics of each item and consequently will not be able to represent the true components and system reliability.

$$\lambda = \frac{Fault}{hours \times 1 \cdot 10^6} \tag{6}$$

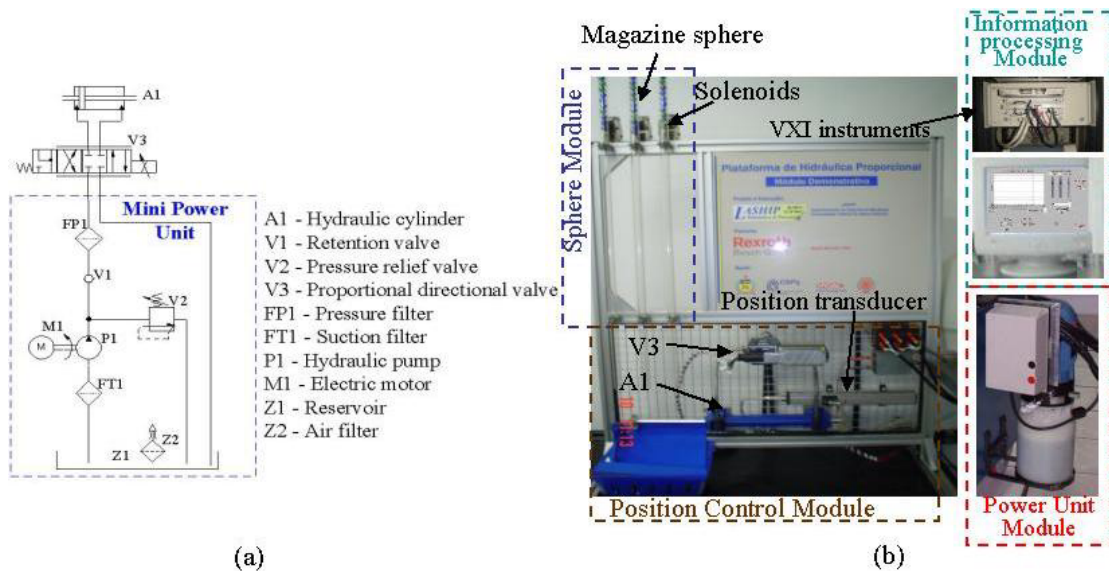

Figure 4 – (a) Hydraulic circuit (b) physical structure

The power unit fault tree indicates that all components are in series. Therefore, any component failure will put the system in a state which is not in accordance with its specification. The reliability estimate for this system was for 1 year, or 8760 working hours. Using Eq. (3), the power unit unreliability and reliability was calculated, as presented in Eq. (7), where $F(x)$ is the system unreliability.

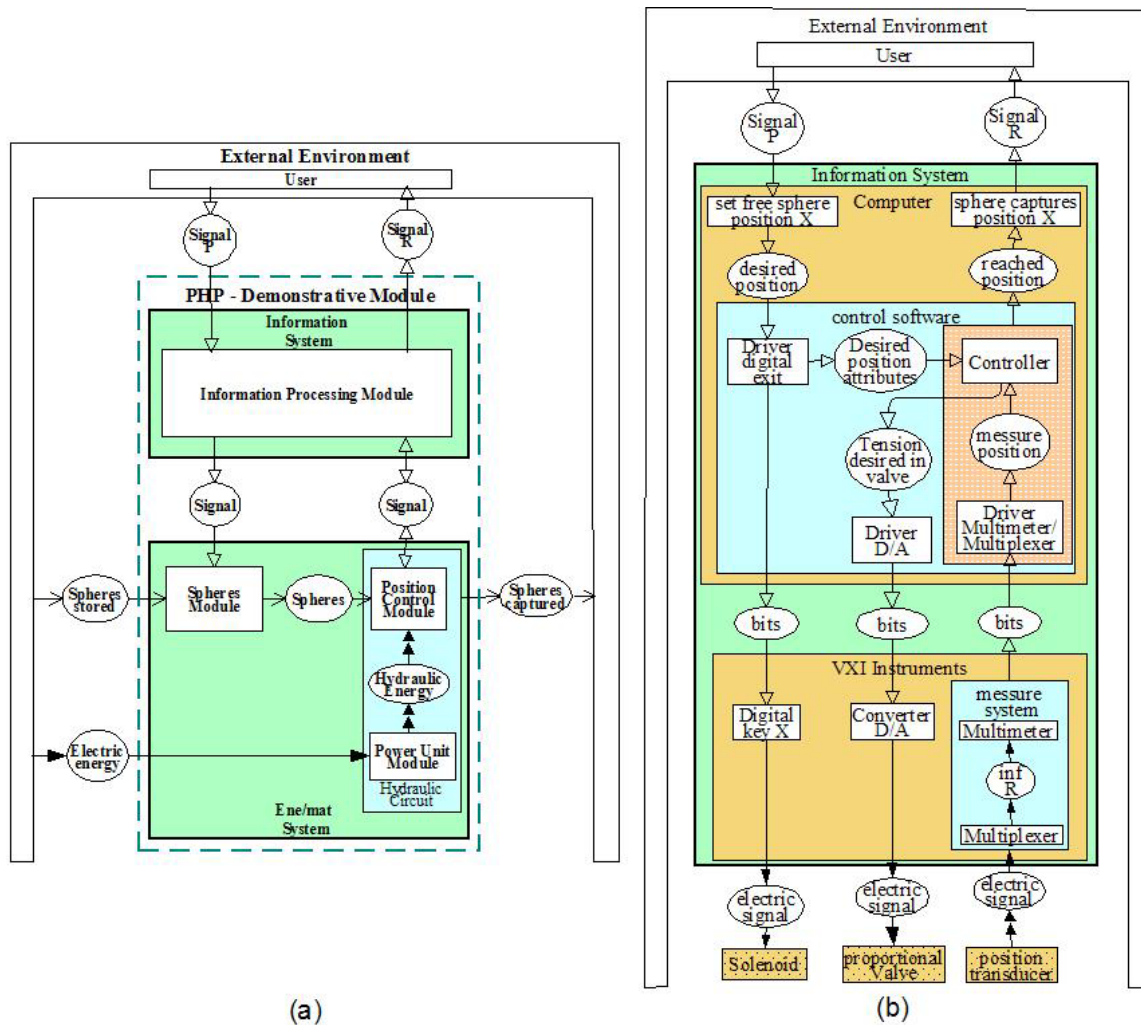

Figure 5 - (a) PHP – Demonstration module model (b) Information processing model

The calculations indicate an unreliability of 21.96%, considering the time of one year or 8760h. Thus, there is a 78.3% reliability that the system will work without any failure occurrence during this period.

$$R(x) = e^{-2.831E-05 \times 8760}$$

$$F(x) = 1 - (e^{-2.831E-05 \times 8760})$$

$$F(x) = 0.2196 \tag{7}$$

$$R(x) = 0.78034$$

Once the unreliability of each module had been calculated it was possible to obtain the total system reliability. For this a fault tree built from a Petri net was used, which facilitated the consideration of the interaction between these modules.

In Fig. 6a this tree is represented considering the unreliability of all modules, where:

- ⇒ M1 - Power Unit Module
- ⇒ M2 - Position Control Module
- ⇒ M3 - Information Processing Module (Computer + VXI Instruments)
- ⇒ M4 - Spheres Module

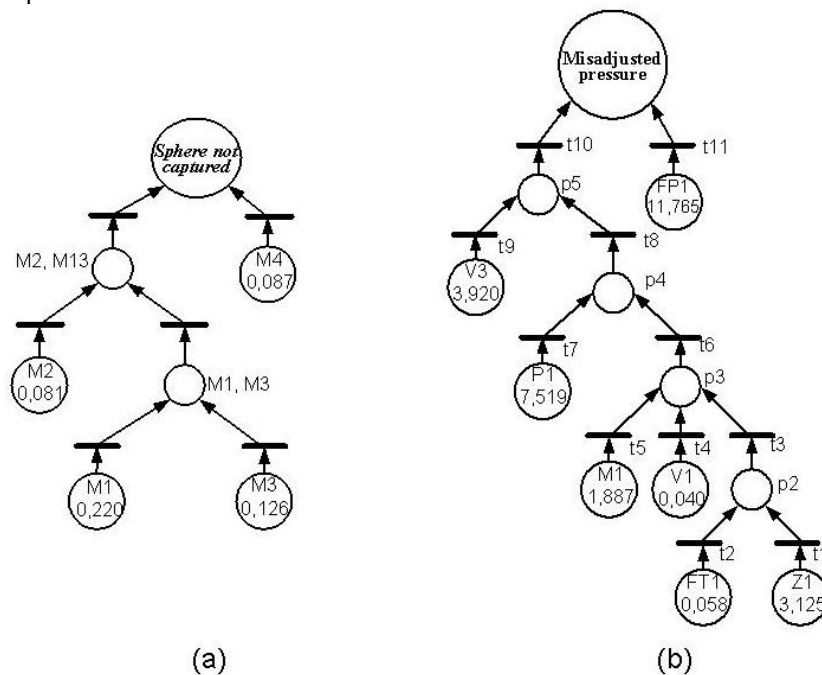

Figure 6 – (a) Fault tree of system modules (b) Fault tree of power unit module

For the calculation of the system unreliability Eq. (4) was used, and for the reliability of the system, Eq.(5).

$$F_{(MA \cup MB)} = F_{MA} + F_{MB} - F_{MA} \cdot F_{MB}$$

$$F_s = 0.4281 \tag{8}$$

$$R_s(x) = 1 - 0.4281$$

$$R_s(x) = 0.5719 \tag{9}$$

In this way it can be concluded that the Proportional Hydraulic Platform - Demonstration Module system has an unreliability of 42.81% for one year or 8760h and consequently a reliability of 57.19%.

Through the identification of system items and the definition of the relationships between them using fault tree analysis; it is possible to systemize the system components FMEA. In this case study only the structure of the FMEA of the system pressure filter is presented, as shown in Tab. 2.

As seen in this table, the failure mode of each system item can cause distinct effects in the system. On the other hand, an effect can be the consequence of distinct failure modes. Thus, the use of the FTA together with the FMEA helps, in a fundamental way, this type of analysis. The distribution of failure modes also can be considered in this analysis. This will assist in decision making in relation to the failure mode that has the highest probability of causing undesirable effects in the system.

Table 2 - FMEA - Failure Modes and Effect Analysis of hydraulic filter. Source VINADÉ (2003)

Component	Function	Failure modes	Effects	Causes
Filter	To reduce to an acceptable level the size and the concentration of contaminant particles, in order to protect the components against premature wear	1) Rupture of filter element	1.1) Binding or Clogging of mobile parts of components	1.1) Flow very high for selected filter
			1.2) Accumulation of dirt greater than cleaning tasks	1.2) High pressure which leads to the accumulation of dirt
		2) Inadequate filter element for system (in terms of the porosity of the filter)	2.1) Greater wear of system components	1.3) Degrading of paper of filter element
			2.2) Binding or Clogging of mobile parts of components	1.4) Wear of components of the filter element
			2.3) Accumulation of dirt greater than cleaning tasks (porosity too low)	2.1) Design error in the selection of porosity
		3) Clogging	3.1) Stop or slowly moving of actuators	3.1) Blockage of oil passing due to contamination of the fluid

6. Results and Conclusions

This study allowed an experiment to be carried out using tools that are being used in distinct applications. The use of a Petri net in the procedural representation of hydraulic systems, intermediated by fault trees for cause-effect relations analysis, elucidates relations of dependence and independence between items, even in the conceptual phase of system. In the same way, FMEA was used to gain perceptions in relation to the function of an item, its possible failure modes, its effect on the system as a whole, and correlations were drawn with the causes. This facilitated the acquiring of detailed knowledge regarding hydraulic systems.

This study offers the following contributions: 1) to education, for the use of some tools to provide knowledge on hydraulic system; and 2) to research, in the unraveling of functions, failure modes, effects, causes, etc., that provide a more systemized treatment of analysis. Finally, although carried as an academic exercise, the authors conclude that the paper presents a very fertile process of analysis, which will be further studied in greater depth.

7. References

- Blischke, W. R., Murthy, D. N. P. **Reliability: Modeling, Prediction, and Optimization**. New York: Ed. John Wiley & Sons, 2000. 817p.
- Cardoso, J., Valette, R. **Redes de Petri**. Florianópolis: Ed. Da UFSC, 1997. 212p.
- De Negri, V. J. **Estruturação da Modelagem de Sistemas Automáticos e sua Aplicação a um Banco de Testes para Sistemas Hidráulicos**. 1996. 180p. Tese (Doutorado em Engenharia Mecânica), Universidade Federal de Santa Catarina, Florianópolis.
- De Negri, V. J. **Sistemas Hidráulicos e Pneumáticos para Controle e Automação: Partes I, II e III**. Apostila (POSMEC) – Universidade Federal de Santa Catarina, Florianópolis, 2001.
- Jingyi, Z., Zhuoru, C., Yiqun, W., Baohai, M., Chengyu Y. The development and prospect of hydraulic reliability engineering. In: INTERNATIONAL CONFERENCE ON FLUID POWER TRANSMISSION AND CONTROL, 5, 2001, Hangzhou, China.
- Knezevic, J., Odoom E. R., Reliability modelling of repairable systems using Petri nets and fuzzy Lambda-Tau methodology. **Reability Engineering and System Safety**, 2001, v 73, p 1-17.
- Liu, T. S., Chiou, S. B., The application of Petri nets to failure analysis. **Reability Engineering and System Safety**, 1997, v 57, p129-142.
- RAC. Reliability Analysis Center, Automated Data book. Department of Defense (DoD). CD-ROM, New York, 1999.
- Riascos, L. A. M.; COZMAN, F. G. ; MIYAGI, P. E. . Detection and Treatment of Faults in Automated Machines Based on Petri Nets and Bayesian Networks. In: INTERNATIONAL SYMPOSIUM ON INDUSTRIAL ELECTRONICS, 2003, Rio de Janeiro.
- Sakurada, E. Y. **As técnicas de Análise dos Modos de Falhas e seus Efeitos e Análise da Árvore de Falhas no desenvolvimento e na avaliação de produtos** 2001. 131p. Dissertação (Mestrado em Engenharia Mecânica) - POSMEC, Universidade Federal de Santa Catarina, Florianópolis.
- SOUZA, A. D. C. **Desenvolvimento de um Sistema para Dimensionamento e Controle de Posicionadores hidráulicos**. 135 f. Dissertação (Mestrado em Engenharia Mecânica) – Universidade Federal de Santa Catarina, Florianópolis, 2005.
- Vinadé, C. A. C. **Sistematização do Processo de Projeto para Confiabilidade e Manutenibilidade Aplicado a Sistemas Hidráulicos e Implementação de um Sistema Especialista**. 2003. 217p. Tese (Doutorado em Engenharia Mecânica) - POSMEC, Universidade Federal de Santa Catarina, Florianópolis.

8. Responsibility notice

Only the authors are responsible for the printed material included in this paper.