

# INSPECTION ROBOT FOR HIGH-VOLTAGE TRANSMISSION LINES

## **Adinan de Souza**

Escola Politécnica da USP  
adinan@usp.br

## **Lucas Antonio Moscato**

Escola Politécnica da USP  
lamoscat@usp.br

## **Melquisedec Francisco dos Santos**

Escola Politécnica da USP  
melki@usp.br

## **Walter de Britto Vidal Filho**

Escola Politécnica da USP  
wbritto@usp.br

## **Gustavo André Nunes Ferreira**

Escola Politécnica da USP  
gandre@usp.br

## **Armindo Gustavo Ventrella**

CTEEP - Companhia de Transmissão de Energia Elétrica Paulista  
aventrella@ctEEP.com.br

*Abstract. The procedure used for inspection and verification of damages in cables is highly dependent on the experience of a skilled technician who, using binoculars, covers the transmission lines in a helicopter, and is able of visualizing points where seems to exist damaged spots in the wires and in insulators of the transmission lines. After this previous identification, teams are sent to verify, with greater detail, if the imperfection is relevant. To confirm the relevance of imperfections, the lines are de-energized and the repair or substitution can be carried out. With the objective of complementing the service of inspection in transmission lines and making it less dependent of the technician skill, the development of a system of services in lines of energy transmission that includes the automation as an auxiliary tool in the identification of imperfections and as a mechanism of diminishing the lines disconnection time. In this work, a mobile robot is presented as a tool to automate the operations of inspection. This robot, currently teleoperated, while travelling upon the wires, gathers cable images, through cameras, and sends them to an operations base.*

**Keywords.** Mobile robot, inspection, visual inspection, service robot.

## **1. Introduction**

The procedure used for inspection and verification of wires or cables of energy transmission lines is subject to the experience of one technician who, through binoculars, covers the lines of transmission in a helicopter and is able of visualize points where seems to exist damages. After this previous identification technical teams are sent to verify, with greater detail, if the imperfection configures a situation of maintenance; the maintenance is carried out in a deenergized line.

New approaches, developed to automated this process, take advantage of global positioning system (GPS) technology, sophisticated cameras and related data-recording equipment, aerial access to remote areas, and robotics (Rubin, 2000). It was known that there is great interest among the energy distribution companies of purchasing a system that allows remote inspection of power lines, particularly in remote areas, by a robotic vehicle.

In (Sawada et. al., 1991) is reported a development of a mobile robot for inspection in a guard cable through eddy current; this robot also presents a mechanism for tower transposition that provides autonomy; and in (Campos et. al., 2002) is developed a robot able to make a semi-automatic installation and removal of aircraft warning spheres. Other works can be found such as (Nakashima et. al., 1995; Yano et. al., 1995; Santamaria et. al., 1997; Peungsungwal et. al., 2000). This paper describes the project of a mobile robot able of carrying out visual inspection of transmission lines, reporting to the operator possible imperfections. This work is presented divided in mechanical system, mechanism for transposition of towers, base – robot operations communication architecture, development of the control system and development of the visual inspection system.

## **2. Mechanical System**

During the development of the robot mechanical system able of moving along a cable of a transmission line is needed the development of the locomotion and actuation subsystems and of a tower transposition mechanism. The methodology of development of the mechanical system included the study of wind effects on the robot. Depending on the results, the configuration of the robot could be changed, since it is foreseen, in this project, the visualization of the

conducting cable, also. Then, some possible configurations were studied to implement the project requirements and, finally the moving power was calculated, based on the robot mass forecast, and the pulleys of vehicle traction system.. Finally, several robot configurations were implemented to be evaluated in laboratory tests.

## 2.1. Wind effect

During the study of the wind effect on the robot, two hypotheses were considered: the robot was modeled as a simple pendulum or as a two opposing pendulums. The results pointed here are qualitative, but lead to conclusions about the influence of the shape and configuration in the reduction of the amplitude of oscillation and in the improvement of the stability of the system.

### 2.1.1. Simple pendulum model

The model of simple pendulum, serving as comparison with the model of opposing pendulums, emphasized the level of interference of the form on the oscillations. For this reason, cylindrical and parallelepipedal forms for the robot were studied. Figure 1 brings the studied geometric configurations.

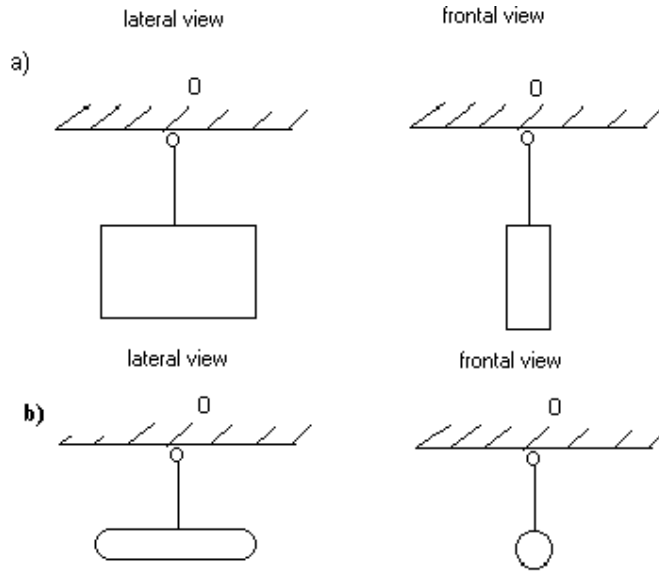

Figure 1. Geometric configurations. a) parallelepipedal. b) cylindrical.

The drag force due to the effect of the wind is:

$$FD = 0,5 * \rho * A * C_D * U^2 \quad (1)$$

Where  $\rho$  is the air density,  $A$  is the projected area of the transversal section in the direction of the fluid draining,  $C_D$  is the coefficient of hydrodynamic drag and  $U$  is the maximum speed of the wind.

The acting component of the wind is, for hypothesis, harmonic, close to the force of drag  $FD$ , or either,  $F(t) = FD \sin \omega t$ , where  $\omega$  it is the frequency of exciting component of the wind. The equation of motion for the robot of the Figure (1), is given by:

$$I_o (d^2\theta / dt^2) (t) + m * g * L * \theta (t) = FD \sin \omega t \quad (2)$$

where,  $I_o$  is the moment of inertia of mass calculated in relation to the point "O",  $(d^2\theta / dt^2) (t)$  is the angular acceleration of the system,  $m$  is the mass of the robot,  $g$  is the acceleration of the local gravity,  $L$  is the length of the connecting rod (with worthless mass) that supports the robot and it is the distance corresponds between the point "O" and the center of mass of the robot,  $\theta (t)$  is the angular displacement of the robot,  $FD$  is the drag force and  $\omega$  is the frequency of the wind component.

Figure 2 presents the amplitude of oscillations for the models of the robots (parallelepipedal and cylindrical shapes). Curves are plotted for transversal and frontal winds directions. It is observed that the cylindrical configuration presents a lower amplitude of oscillation, either for frontal and lateral winds. Thus, the conclusion is that the shape adopted for the robot gives a greater or minor influence for the wind on the amplitude of the oscillations that the robot have to bear when it travelling through high-voltage cables. It is necessary to observe also that the cross-

section area also influences the amplitude of the drag force of the wind, becoming noninteresting to increase this area to obtain an improvement in the hydrodynamic shape of the robot.

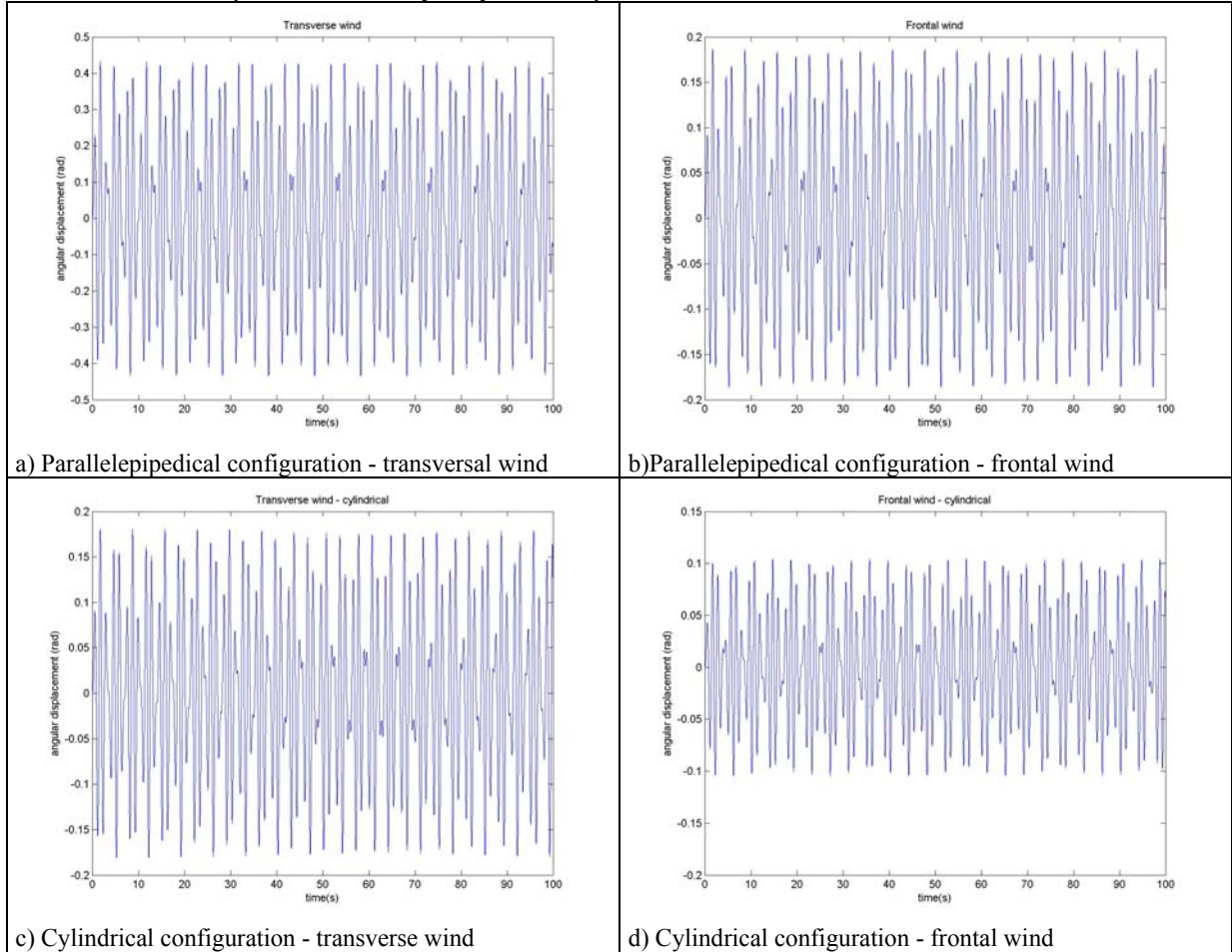

Figure 2. Curves of the action of the wind applied in transverse and frontal directions on the parallelepipedical and cylindrical robot.

### 2.1.2. Opposing pendulums model

A configuration that diminishes the amplitude of oscillation of the robot due to the effect of the wind is two cylinders, one above and other below the cable. In this case, preserving the input data of previous models, allowed a qualitative comparison. Figure (3) brings the schematic model of the opposing pendulums.

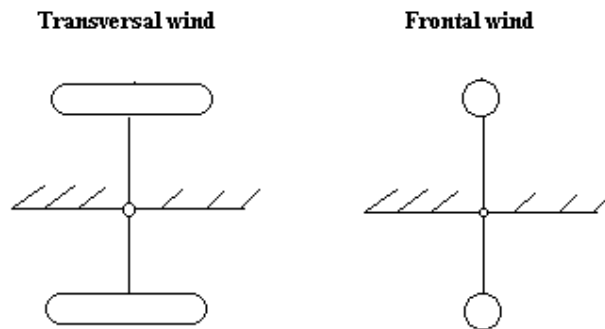

Figure 3. Schematic model of the opposing pendulums

The drag force due to the the wind is given in Eq. (1). The exciting component of the wind is considered to be harmonic. The equation of motion for the robot is given by:

$$(I_o + i_o) (d^2\theta / dt^2) (t) + (M * L - m * l) * \theta (t) = (F_D * L - F_d * l) \sin \omega t \quad (3)$$

where  $I_o$  is the moment of inertia of the mass of the lower cylinder calculated in relation to the point O,  $i_o$  is the moment of inertia of the mass of the upper cylinder calculated in relation to the point O,  $(d^2\theta / dt^2) (t)$  is the angular acceleration of the system,  $M$  is the mass of the lower cylinder,  $m$  is the mass of the upper cylinder,  $g$  is the acceleration of the local gravity,  $L$  is the length of the connecting rod (with worthless mass),  $l$  is the length of the connecting rod (with worthless mass) being the distance between point O and the center of mass of each cylinder,  $\theta(t)$  is the angular displacement,  $F_D$  is the amplitude of the drag force of the lower cylinder and  $F_d$  is the amplitude of the drag force of the upper cylinder and  $\omega$  it is the frequency of the wind. In Figure (4) the amplitude of oscillations for the opposing pendulums model considering wind acting in the transversal and frontal directions are presented.

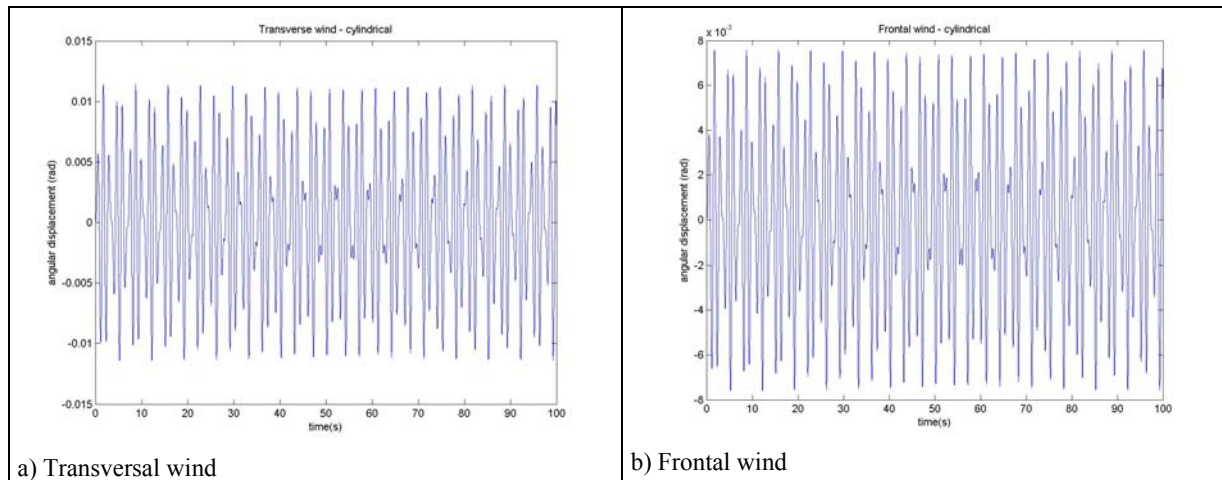

Figure 4. Amplitude of the oscillations for the opposing pendulums model.

The conclusions on the influence of the action of the wind on the robot oscillation, when moving along the cable are:

- ❑ In the model of simple pendulum was possible to show that the hydrodynamic shape is an important component on the amplitude of oscillation of the robot;
- ❑ Also in the model of simple pendulum was possible to directly show that the increase of the area caused an increase of the amplitude of oscillation.

From the model of opposing pendulums we conclude that:

- ❑ The proximity of the dimensions and geometry of the upper and lower bodies decreases the amplitude of oscillation;
- ❑ As the ratio between mass of the lower upper body increases the amplitude of oscillation decreases;
- ❑ If the two bodies have the same geometry and dimensions, the amplitude due to the wind effect is null (equal to the zero);
- ❑ When the mass of the upper body is bigger or equal to the lower, the system becomes unstable.

## 2.2 Mechanical model

During the development of the mechanical architecture for the inspection robot, beyond all the requirements related to the wind effect, the requirements to allow the robot transposition of tower cable connections were considered. An evolutive methodology was adopted to design the robot mechanical prototype. The design cycle was incremental and consists of develop a mechanical configuration, develop detailed mechanical project, build a test prototype and develop improvements. Several configurations for the transmission lines inspection robot were proposed and tested. Figure (5) shows all these configurations.

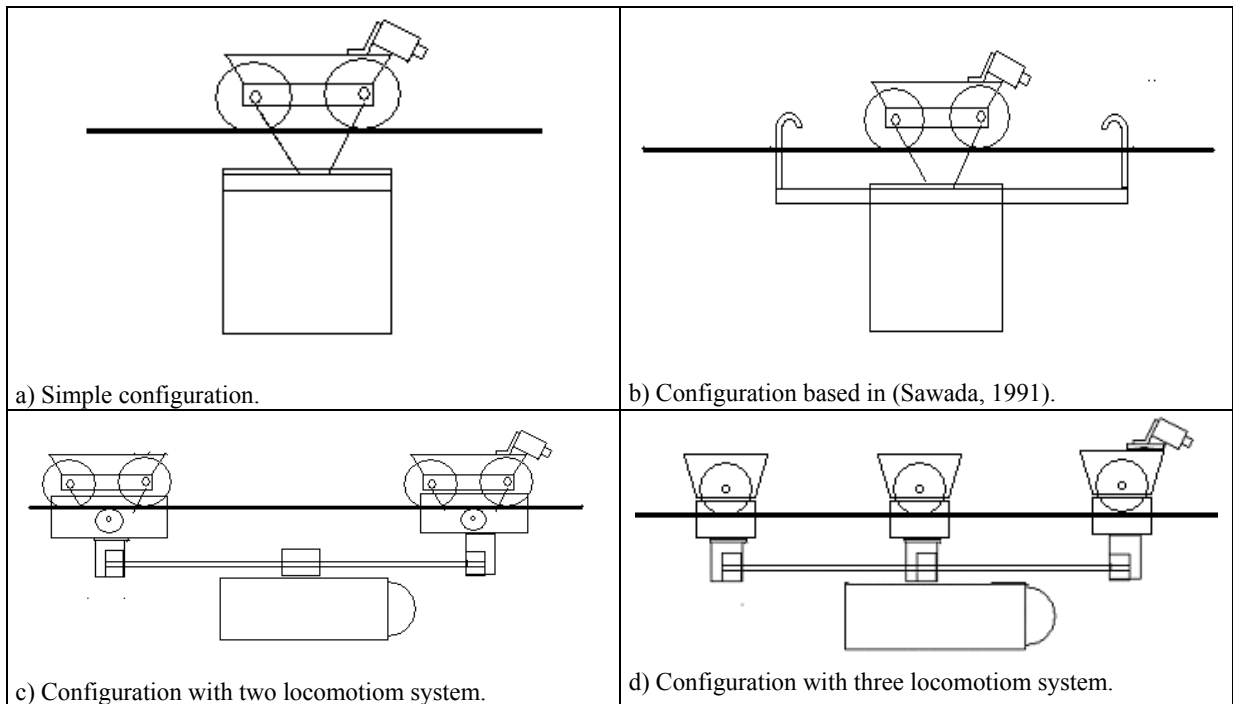

Figure 5. Mechanical configuration of the robots.

Configuration of Figure (5 a) corresponds to an initial model, without capability of towers transposition, but already able to inspect the cable. This configuration had a set of two wheels, to move the inspection vehicle along the cable and one actuator for traction.

Configuration in Figure (5 b) is an evolution and has one track that goes through the electronics box; Besides the electronics, inside the box there are a set of actuators for box movements and a set of batteries. There are two hooks, one at each end of the track. The development of this mechanism was based upon the configuration developed by Sawada (Sawada, 1991) as can be observed in Figure (6) and the procedure for tower cable connection transposition occurs as follows: the hook touches the cramp that supports the cable, transposes the cable and the vehicle stops, the first hook grabbing the cable beyond the obstacle; then a control procedure triggers a mechanism actuation which raises the wheels, fixes the hooks in the cable (one at each side of the cramp obstacle) and bends the box; the box is moved along its track until it approaches the forward hook; then, it hangs again from the cable and the track moves back to its original position.

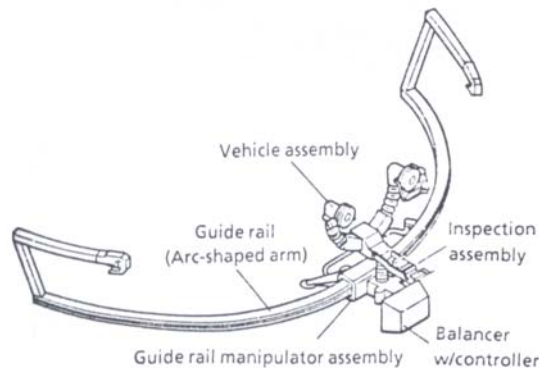

Figure 6. Robot configuration (Sawada, 1991).

The configuration in Figure (5 c) has two sets of three wheels to move the robot along the cable. The transposition of towers occurs in a similar way showed in figure 7 as follows: the first set of wheels touches the cramp that holds the cable, the box moves back along the track, as visualized in Figure (7)); at this moment the forward set of wheels bends and the backward set of wheels is moved until it surpasses holding cramp; then the forward set of wheels comes back to the cable, the box is moved forward until being under it, and the backward set of wheels

bends; the robot moves until the backward set of wheels surpasses the holding cramp. The configuration in Figure (5 d) is equivalent but it is not necessary to move the box along the track.

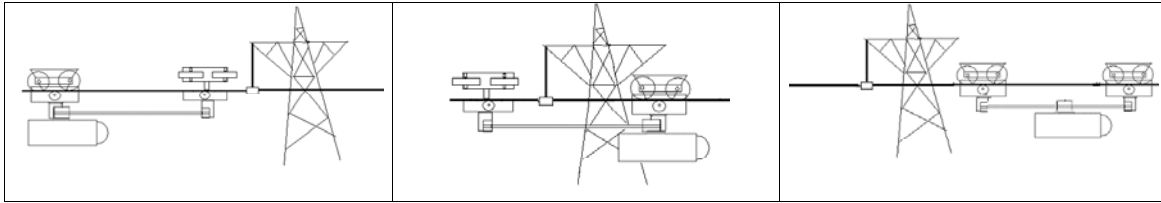

Figure 7. Representation of the robot in the transposition of towers

### 3. Communication and control architecture

Figure 8 shows a simplified diagram containing the circuits (drives of power, switches, circuits and processing units) and devices (motors, servomotors, video-cameras, modems, transmitters and receivers of radio frequency) to be embarked in the robot, as well as the communication between these devices.

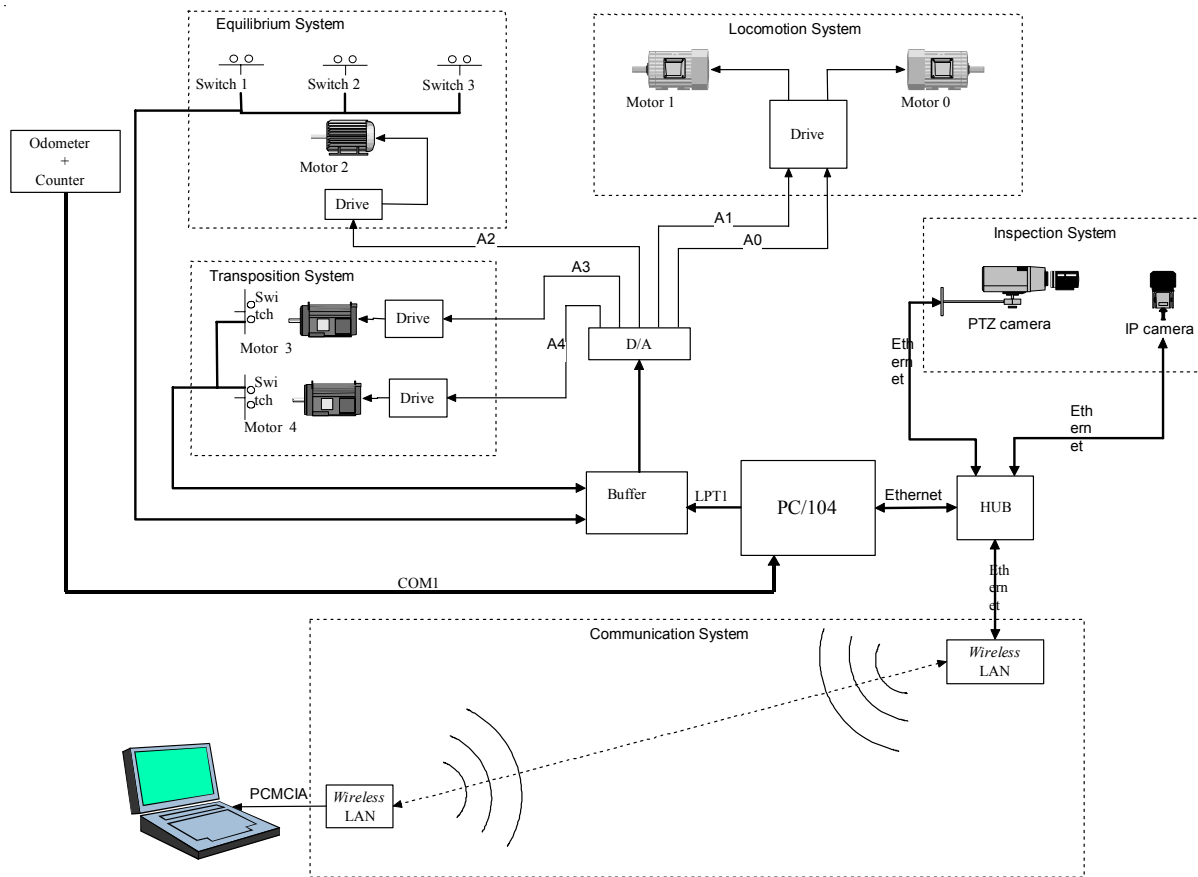

Figure 8. Logical view of the system.

In the logical architecture of the control system shown in the Figure (8), there are one radio at the robot for sending both the commands and images. In this architecture another radio was installed in the Ethernet port of the base computer. The robot was connected via hub to a PC104 ;at the same hub were connected , also, 2 IP cameras and the radio. This architecture was efficient and simpler for testing, since the images were received with good quality and the response time to commands was coherent with requirements.

#### 4. Conclusions

In this work, a tool to automate the inspection of transmission lines was developed, decreasing the time interval of line disconnection and increasing the safety of the maintenance procedures. This mobile robot can be used as basis for future developments, generating a more complete system for energy transmission lines services. Among future developments the implementation of a tool to place and remove aircraft warning spheres is foreseen, as well as tools to carry out repair in damaged cables; and, finally, a system to execute autonomous inspection through the recognition of damages in the ground cables.

#### 5. Acknowledgement

The authors gratefully acknowledges CTEEP and FDTE for their sponsorship.

#### 6. References

- Campos, M. F. M.; Pereira, G. A. S.; Vale, S. R. C.; Bracarense, A. Q.; Oliveira, M. P. and Pinheiro, G. A., 2002. "A mobile manipulator for installation and removal of aircraft warning spheres on aerial power transmission lines". In Proceedings of the IEEE Conference on Robotics and Automation, IEEE Conference on Robotics and Automation, Washington, DC, 2002, 3559-3564.
- Davison, A. J.; Kita, N. 2002. "Active Visual Localization For Multiple Inspection Robots". Advanced Robotics.
- Dixon, W. E.; Dawson, D. M.; Zergeroglu, E.; Behal, A., 2001. "Adaptive Tracking Control Of A Wheeled Mobile Robot Via An Uncalibrated Camera System". IEEE Transactions On Systems Man And Cybernetics Part B- Cybernetics.
- Gundimeda, D. P.; Veluvali, S.K. 1991. "An Automated Vision Based Approach For High-Voltage Insulator Testing". Electric Power Systems Research.
- Jones, D.I.; Earp, G.K., 2001 "Camera sightline pointing requirements for aerial inspection of overhead power lines" Electric Power Systems Research 57, pp. 73-82.
- Nakashima, M.; Yano, K.; Maruyama, Y.; Yakabe, H., 1995 "A hot line work robot system "Phase II" and its human-robot interface "MOS" ". Proceedings of the IEEE/RSJ International Conference on Intelligent Robots and Systems, vol.2, pp. 116-123.
- Peungsungwal, S.; Pungsiri, B.; Chammongthai, K.; Okuda, M., 2001. "Autonomous robot for a power transmission line inspection". Proceedings of the IEEE International Symposium on Circuits and Systems, vol. 3, pp. 121-124.
- Rubin, Lew, 2000. "The future of power line inspection". Electrical World T&D September/October.
- Santamaria, A.; Aracil, R.; Tuduri, A.; Martinez, P.; Val, F.; Penin, L. F.; Ferre, M.; Pinto, E.; Barrientos, A. 1997. "Teleoperated robots for live power lines maintenance (ROBTET)". Proceedings of the 14<sup>th</sup> International Conference and Exhibition on Electricity Distribution. Part 1: Contributions, vol. 3.
- Sawada, J.; Kusumoto, K.; Maikawa, Y.; Munakata, T. and Ishikawa, Y., 1991, "A mobile robot for inspection of power transmission lines". IEEE Transactions on Power Delivery, vol. 6, pp 309-315, Jan.
- Yano, K.; Maruyama, Y.; Morita, K.; Nakashima, M. 1995. "Development of the semi-automatic hot line work robot system "Phase II"". Proceedings of the 7<sup>th</sup> International Conference on Transmission and Distribution Construction and Live Line Maintenance, pp. 212-218.

#### 7. Copyright Notice

The author is the only responsible for the printed material included in his paper.