

APPLICATION OF AN ALTERNATIVE THERMOECONOMIC APPROACH TO TWO BENCHMARK REFRIGERATION CYCLES

Atilio Barbosa Lourenço, atiliobl@gmail.com

José Joaquim Conceição Soares Santos, jjessantos@yahoo.com.br

João Luiz Marcon Donatelli, donatelliufes@gmail.com

Federal University of Espírito Santo – 514 Fernando Ferrari Avenue, Campus of Goiabeiras, Vitória, ES, Brazil

Abstract. *In any energy system, in the same manner that there are productive components, there also exist dissipative components. Although there has been an advance in the development of thermoeconomic criteria for dissipative components allocation, this problem is still open. The introduction of the negentropy in thermoeconomics represented a great advance, since this magnitude allows quantifying the condenser product. However, negentropy itself does not allow defining the product of valves. To overcome such a limitation, the UFS Model was proposed. This approach is based on the disaggregation of the physical exergy into three terms, namely, internal energy, flow work and syntropy. In this paper, the UFS Model is applied to the Carnot refrigeration cycle and also to the simple vapor compression refrigeration cycle. The application to the former cycle is done to show the consistency of the UFS Model and the application to the latter one is done as a case study. Results show that the exergetic unit costs of productive flows are greater than or equal to one and product-resource ratio of each productive unit are less than or equal to one, depending on the situation, i.e., when considering the simple vapor compression cycle or the Carnot cycle, respectively.*

Keywords: *Exergy Disaggregation, Refrigeration Cycle, Thermoeconomics, Valves Isolation.*

1. INTRODUCTION

Thermoeconomics can be considered a new science which, by connecting Thermodynamics and Economics, provides tools to solve problems in complex energy systems that can hardly or not be solved using conventional energy analysis techniques based on First Law of Thermodynamics (mass and energy balance), as for instance a rational price assessment to the products of a plant based on physical criteria (Erlach et al., 1999).

In any energy system, in the same manner that there are productive components, there also exist dissipative components. An energy system has a defined productive structure, but also dissipative ones and both structures are not independent. Although there has been an advance in the development of criteria for the cost allocation of residues, this problem is still open (Torres et al., 2008).

One of the thermoeconomic methodologies challenges is to define the productive structure of thermal systems that allows allocating rationally the cost of dissipative components to final products. The way in which we define the productive structure is a key point of the thermoeconomic modeling (Lozano and Valero, 1993). Different thermoeconomic methodologies can provide different cost values when they define different productive structures. Cost validation is a key issue in thermoeconomics which has not been properly solved yet. However, one considers that cost validation can be designed using the physical behavior of the plant together with Thermodynamics, because irreversibility is the physical magnitude generating the cost (Valero et al., 2006).

According to Torres et al. (1996), depending on the type of analysis, different levels of accuracy of the results are required. Sometimes, under a thermoeconomic analysis point of view, it is necessary to consider a component as a group of subsystem (made up of a group of subsystem) or a mass or an energy flow rate consisting of several components, for example thermal, mechanical or chemical exergy, as proposed by Tsatsaronis (1987), or even to include fictitious flow stream (negentropy) without a physical existence in the flow sheet of the plant, as proposed by Frangopoulos (1987).

The negentropy flow was applied in thermoeconomics joined up with exergy flow (Frangopoulos, 1987). Negentropy was defined as the negative variation of entropy multiplied by the temperature of the environment. This application represented a great advance in the discipline, since it allowed one to quantify the condenser product, which was not possible before because the condenser is a dissipative component, whose product cannot be expressed in terms of exergy. The concept of negentropy was also used in order to define the productive structure of a gas turbine cogeneration system by Lozano and Valero (1993) and by von Spakovsky (1994).

However, when negentropy is applied as a fictitious flow (joined up with exergy flow), it is not possible to obtain an efficiency based on the Second Law of Thermodynamics (product-resource ratio), since the product of dissipative units might be higher than its resource, yielding unit costs lesser than one for some flows. This happens because exergy loss is considered as fuel (in this work also called resource) and negentropy (in this work also called syntropy) as product. To overcome this problem, the H&S Model was developed to allocate wastes of dissipative component (the condenser) in the thermoeconomic analysis of energy systems (Santos et al., 2009). The basis of this method is the

breakup of exergy into enthalpy and negentropy. Enthalpy flows replace exergy flows and negentropy flows are used as a component of exergy. Therefore, the productive structure is defined using enthalpy and negentropy flows.

The disaggregation of exergy in thermal and mechanical components does not allow defining the product of the condenser. On the other hand, this goal is achieved when negentropy is used both as a fictitious flow (Frangopoulos, 1987) and as an exergy component flow (Santos et al., 2009). But none of them allows defining the product of valves (for instance, in a refrigeration cycle). Thus, this paper presents an application of the so-called UFS Model, which is based on disaggregation of physical exergy into internal energy ($U-U_0$), flow work ($pV-p_0V_0$) and the here called syntropy ($T_0S-T_0S_0$). This disaggregation of the physical exergy allows the isolation of valves in the productive structure, so defining their resources and products, without generating any problems (Lourenço et al., 2011).

2. PHYSICAL MODELS

Figure 1 represents the physical structure of the Carnot cycle, which is defined as having four units: the compressor (cmp), the turbine (trb), the evaporator (evp) and the condenser (cnd) and the physical structure of the simple cycle, which is defined as also having four units: the compressor (cmp), the expansion valve (vlv), the evaporator (evp) and the condenser (cnd).

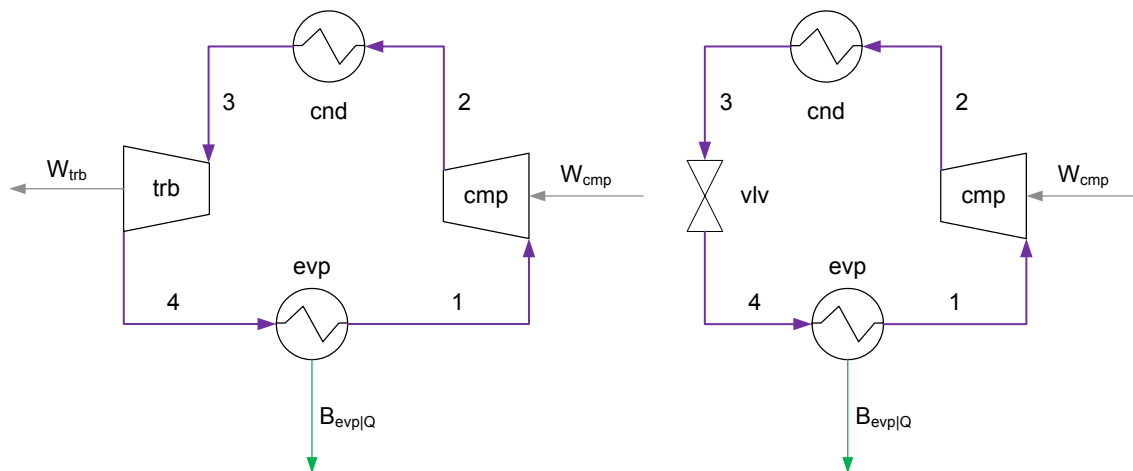

Figure 1. Physical structures of the Carnot cycle and the simple cycle, respectively.

Assumptions made for the modeling are: Equipments are analyzed as control volumes at steady state and are adiabatic; The exergy provided by the evaporator to the cold region is modeled as an exergy flow associated with the heat transfer; There is no pressure drop for flow through heat exchangers (only for the simple cycle); Kinetic and potential energy effects are negligible.

3. THERMOECONOMIC MODELING

In order to carry out a thermoeconomic analysis, the UFS Model defines the productive purpose of the subsystems (resources and products), as well as the distribution of the external resources and internal products throughout the system. The productive structure could be represented by means of a functional diagram. In this section, basic concepts of the cost formation are shown. After that, the UFS Model is applied to generate the productive structure of the studied refrigeration cycles.

3.1 Productive Structure and Costs Formation

The productive structure represents the cost formation process of the cycle. The external resource consumed by the cycles is the mechanical power demanded by the compressor (W_{cmp}). The functional product is the exergy, which is associated to the heat transfer, provided by the evaporator (B_{evplQ}). Rectangles are real units that represent the actual equipment of the cycle. Rhombus and circles are fictitious units called junctions and bifurcations, respectively. Each productive unit has inlet and outlet arrows that represent its resources and products, respectively. Each productive flow is defined based on physical flows.

The mathematical model for the mechanical power allocation is obtained by formulating the cost balance equation in each productive unit, or subsystem, of the productive structure, as shown in Eq. (1), where k is the exergetic unit cost of productive flows (unknown variable) and Y represents the generic productive flow, which can be internal or external. The exergetic unit cost of the mechanical power is equal to one.

$$\sum(k \cdot Y) = 0 \quad (1)$$

Efficiency is defined as the ratio of the desired result for an event to the input required to accomplish such an event. Therefore, when one defines the fuel and the product during the thermoeconomic modeling, one takes into account that the Second Law efficiency ranges from zero, for a totally irreversible process, to 100 percent, for a totally reversible process (Çengel and Boles, 2006). Thus, the exergetic unit cost is the inverse of an efficiency, which is defined as the ratio between the products of a productive unit and the external fuels of the plant.

Since the number of flows is always greater than the number of productive units, some auxiliary equations attribute the same exergetic unit cost to all of productive flows leaving the same bifurcation. The solution of the set of cost balance equations allows the attainment of the exergetic unit cost of each internal flow and final product.

3.2 The UFS Model

The physical exergy (B_i) of a refrigerant stream is written as shown in Eq. (2), where h_0 and s_0 are the specific enthalpy and the specific entropy, both at the dead state, respectively. Dead state is at T_0 , the reference temperature, and at p_0 , the reference pressure.

$$B_i = m_i \cdot [(h_i - h_0) - T_0 \cdot (s_i - s_0)] \quad (2)$$

To generate the productive structure, the UFS Model considers that the physical exergy must be disaggregated into three components, which are the internal energy (U_i), the flow work (F_i) and the syntropy (S_i). The productive structure of the Carnot cycle is shown in Fig. 2 and the productive structure of the simple cycle is shown in Fig. 3.

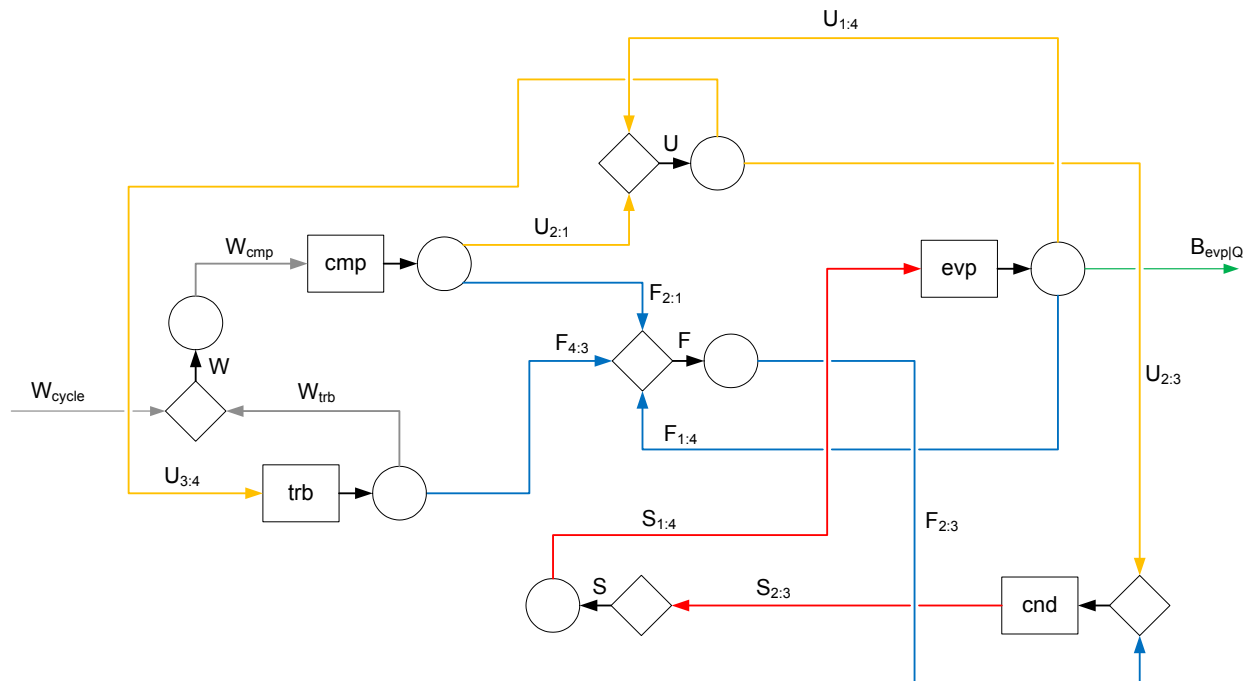

Figure 2. Productive structure of the Carnot cycle.

The products and the fuels of each subsystem, in terms of internal energy, flow work and chemical exergy component are defined based on the quantity of these magnitudes added to and removed from the working fluid, respectively. On the other hand, the entropic component flows are the products of the subsystems that decrease the working fluid entropy, and subsystems that increase the working fluid entropy are entropic components consumers.

The physical flows are calculated as shown in Eqs. (3-5), where u_0 and v_0 are the specific internal energy and the specific volume, both at the dead state, respectively. One must remind that the enthalpy is defined as the sum between the internal energy and the flow work.

$$U_i = m_i \cdot (u_i - u_0) \quad (3)$$

$$F_i = m_i \cdot (p_i \cdot v_i - p_0 \cdot v_0) \quad (4)$$

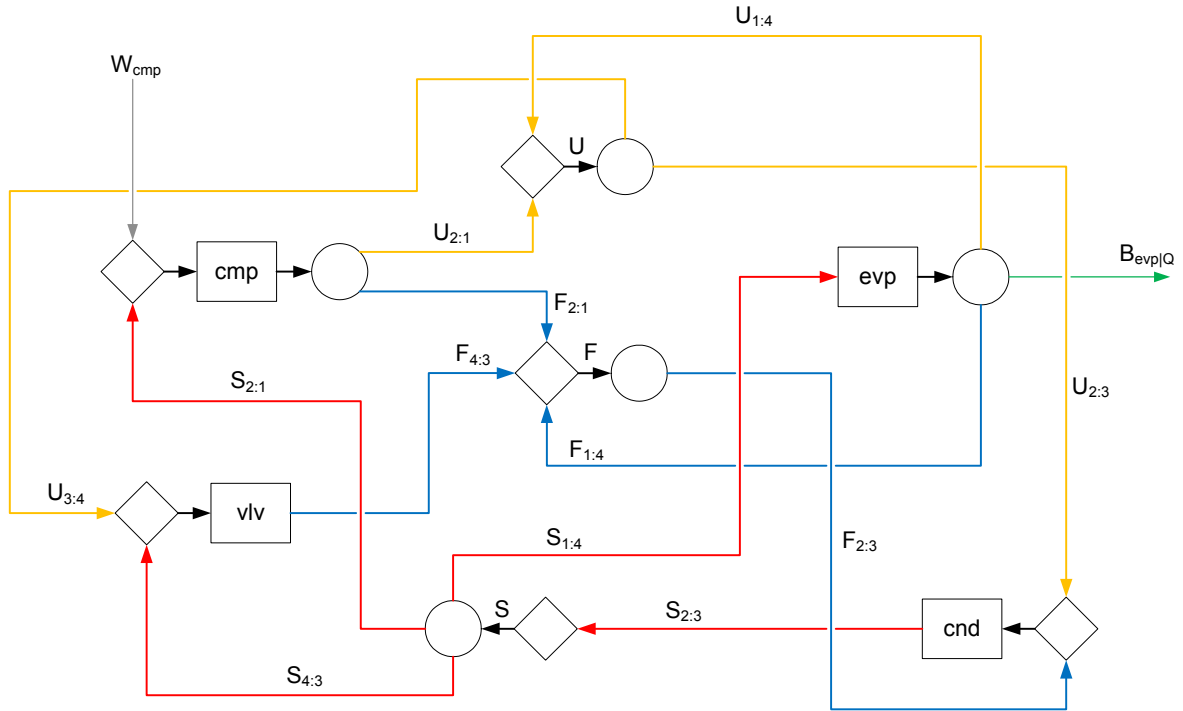

Figure 3. Productive structure of the simple cycle.

$$S_i = m_i \cdot T_0 \cdot (s_i - s_0) \quad (5)$$

Chemical exergy is not considered because there is no changing in the composition of the fluid throughout the processes of the cycles.

Internal flows of the productive structure are calculated using Eqs. (6-11).

$$U_{i,j} = m_i \cdot (u_i - u_j) \quad (6)$$

$$F_{i,j} = m_i \cdot (p_i \cdot v_i - p_j \cdot v_j) \quad (7)$$

$$S_{i,j} = m_i \cdot T_0 \cdot (s_i - s_j) \quad (8)$$

$$U_{i,j'} = m_j \cdot (u_i - u_j) \quad (9)$$

$$F_{i,j'} = m_j \cdot (p_i \cdot v_i - p_j \cdot v_j) \quad (10)$$

$$S_{i,j'} = m_j \cdot T_0 \cdot (s_i - s_j) \quad (11)$$

The set of cost balance equations for the Carnot cycle is given by Eqs. (12-19).

$$k_{cmp} \cdot (U_{2:1} + F_{2:1}) - k_W \cdot W_{cmp} = 0 \quad (12)$$

$$k_{cnd} \cdot S_{2:3} - (k_U \cdot U_{2:3} + k_F \cdot F_{2:3}) = 0 \quad (13)$$

$$k_{trb} \cdot (W_{trb} + F_{4:3}) - k_U \cdot U_{3:4} = 0 \quad (14)$$

$$k_{evp} \cdot (B_{evp} + U_{1:4} + F_{1:4}) - k_S \cdot S_{1:4} = 0 \quad (15)$$

$$k_U \cdot (U_{2:3} + U_{3:4}) - (k_{cmp} \cdot U_{2:1} + k_{evp} \cdot U_{1:4}) = 0 \quad (16)$$

$$k_F \cdot F_{2:3} - (k_{cmp} \cdot F_{2:1} + k_{evp} \cdot F_{1:4} + k_{trb} \cdot F_{4:3}) = 0 \quad (17)$$

$$k_S \cdot S_{1:4} - k_{cnd} \cdot S_{2:3} = 0 \quad (18)$$

$$k_W \cdot W_{cmp} - k_{trb} \cdot W_{trb} = W_{cycle} = W_{cmp} - W_{trb} \quad (19)$$

The set of cost balance equations for the simple cycle is given by Eqs. (20-26).

$$k_{cmp} \cdot (U_{2:1} + F_{2:1}) - k_S \cdot S_{2:1} = W_{cmp} \quad (20)$$

$$k_{cnd} \cdot S_{2:3} - (k_U \cdot U_{2:3} + k_F \cdot F_{2:3}) = 0 \quad (21)$$

$$k_{vlv} \cdot F_{4:3} - (k_U \cdot U_{3:4} + k_S \cdot S_{4:3}) = 0 \quad (22)$$

$$k_{evp} \cdot (B_{evp} + U_{1:4} + F_{1:4}) - k_S \cdot S_{1:4} = 0 \quad (23)$$

$$k_U \cdot (U_{2:3} + U_{3:4}) - (k_{cmp} \cdot U_{2:1} + k_{evp} \cdot U_{1:4}) = 0 \quad (24)$$

$$k_F \cdot F_{2:3} - (k_{cmp} \cdot F_{2:1} + k_{evp} \cdot F_{1:4} + k_{vlv} \cdot F_{4:3}) = 0 \quad (25)$$

$$k_S \cdot (S_{1:4} + S_{2:1} + S_{4:3}) - k_{cnd} \cdot S_{2:3} = 0 \quad (26)$$

3.3 Applying Examples

Considering the simple cycle, let the isentropic efficiency of the compressor (η_C) be equal to 0.90, the temperature difference between the state 3 and the environment (ΔT_{cnd}) be equal to 5 K and the temperature difference between the cold region which receives the exergy provided by the evaporator and the state 4 (ΔT_{evp}) be equal to 5 K. The reference temperature is equal to 294.15 K

Streams parameters of the Carnot cycle and the simple cycle are presented in Tab. 1. Streams 1, 2 and 4 have different thermodynamic properties in each situation (subscripts *c* and *s*, respectively). The refrigerant is R-134a, whose mass flow is equal to 0.8 kg/s for both cycles. Thermodynamic properties, in this case specific internal energy, specific volume and specific entropy, of the fluid are evaluated from the database of the software Engineering Equation Solver (EES).

The exergy provided by the evaporator is calculated by multiplying the exergetic temperature factor, considering the evaporation temperature, and the value of the heat transfer associated to such equipment.

Table 1. Streams parameters and thermodynamic properties of R-134a.

Physical Flow		<i>p</i> [kPa]	<i>T</i> [K]	<i>u</i> [kJ/kg]	<i>v</i> [m ³ /kg]	<i>s</i> [kJ/kg-K]
<i>i</i>	Description					
1 _c	Mixture (<i>x</i> = 0.9846)	293.01	273.15	227.40	0.06820	0.9202
1 _s	Vapor (<i>x</i> = 0)	293.01	273.15	230.16	0.06925	0.9314
2 _c	Vapor (<i>x</i> = 0)	685.84	299.15	244.12	0.02998	0.9202
2 _s	Vapor	685.84	304.34	248.80	0.03093	0.9378
3	Liquid (<i>x</i> = 0)	685.84	299.15	87.26	0.00083	0.3290
4 _c	Mixture (<i>x</i> = 0.1714)	293.01	273.15	82.24	0.01251	0.3290
4 _s	Mixture (<i>x</i> = 0.1811)	293.01	273.15	83.97	0.01318	0.3361

4. RESULTS AND DISCUSSION

Table 2 shows the productive flows, its values and its respective exergetic unit costs for the given numerical data. One should note that there is no exergetic unit cost value less than one considering the simple cycle and all exergetic unit costs of the Carnot cycle are equal to one.

Taking the ratios between products and resources of the productive units, such ratios are defined based on the Second Law of Thermodynamics, the set of Eqs. (27-34) is generated. Table 3 shows the values of the product-resource ratios of the productive units for the given numerical data. One should note that there is no product-resource ratio value greater than 100%.

$$\eta_{cmp} = \frac{U_{2:1} + F_{2:1}}{W_{cmp} + S_{2:1}} \quad (27)$$

$$\eta_{cnd} = \frac{S_{2:3}}{U_{2:3} + F_{2:3}} \quad (28)$$

$$\eta_{trb} = \frac{W_{trb} + F_{4:3}}{U_{3:4} + F_{4:3}} \quad (29)$$

$$\eta_{vlv} = \frac{F_{4:3}}{U_{3:4} + F_{4:3}} \quad (30)$$

Table 2. Exergetic unit costs.

Productive Flow	Value [kW]		Exergetic Unit Cost [kW/kW]	
	Carnot Cycle	Simple Cycle	Carnot Cycle	Simple Cycle
U _{2:1}	13.37	14.91	1.000	1.199
U _{2:3}	125.49	129.23	1.000	1.990
U _{3:4}	4.02	2.63	1.000	1.990
U _{1:4}	116.13	116.95	1.000	2.091
F _{2:1}	0.46	0.74	1.000	1.199
F _{2:3}	15.99	16.51	1.000	2.241
F _{4:3}	2.48	2.63	1.000	3.283
F _{1:4}	13.05	13.14	1.000	2.091
S _{2:1}	-----	1.52	-----	2.054
S _{2:3}	141.47	143.27	1.000	2.054
S _{4:3}	-----	1.66	-----	2.054
S _{1:4}	141.47	140.09	1.000	2.054
B _{evpQ}	12.30	7.48	1.000	2.091
W _{cmp}	13.84	15.65	1.000	1.000
W _{trb}	1.54	-----	1.000	-----

$$\eta_{evp} = \frac{B_{evpQ} + U_{1:4} + F_{1:4}}{S_{1:4}} \quad (31)$$

$$\eta_U = \frac{U_{2:3} + U_{3:4}}{U_{2:1} + U_{1:4}} \quad (32)$$

$$\eta_F = \frac{F_{2:3}}{F_{2:1} + F_{4:3} + F_{1:4}} \quad (33)$$

$$\eta_S = \frac{S_{2:1} + S_{4:3} + S_{1:4}}{S_{2:3}} \quad (34)$$

Table 3. Product-resource ratios of productive units.

Productive Unit	Ratio Value	
	Carnot Cycle	Simple Cycle
Compressor (cmp)	100.00%	91.16%
Condenser (cnd)	100.00%	98.30%
Turbine (trb)	100.00%	-----
Expansion Valve (vlv)	-----	61.36%
Evaporator (evp)	100.00%	98.21%
Internal Energy (U)	100.00%	100.00%
Flow Work (F)	100.00%	100.00%
Syntropy (S)	100.00%	100.00%

The exergetic efficiency of the Carnot cycle, given by Eq. (35), is equal to 1.0000 and the exergetic efficiency of the simple cycle, given by the Eq. (36), is equal to 0.4782.

$$\varepsilon_c = \frac{B_{evp}}{W_{cmp} - W_{trb}} = \frac{1}{k_{evp}} \quad (35)$$

$$\varepsilon_s = \frac{B_{evp}}{W_{cmp}} = \frac{1}{k_{evp}} \quad (36)$$

The UFS Model was proposed in order to define a product for valves and, in general, for units or processes that are modeled as isenthalpic, because the H&S Model is not able to do it. Nevertheless, the UFS Model keeps all features of the H&S Model, i.e., one can say that the UFS Model is an extension of the H&S Model and the application of the former only could be justified, e.g., whether there is a valve in the structure, because of the increasing of the modeling complexity.

5. CLOSING REMARKS

In this paper, the UFS Model was applied to the Carnot refrigeration cycle and also to the simple vapor compression refrigeration cycle. The application to the former cycle was done to show the consistency of the UFS Model and the application to the latter one was done as a case study. Results show that the exergetic unit costs of productive flows are greater than or equal to one and product-resource ratio of each productive unit are less than or equal to one, depending on the situation, i.e., when considering the simple vapor compression cycle or the Carnot cycle, respectively.

Although it was not done in this paper, it can be shown that the UFS Model can be used in order to quantify irreversibilities as well as the conventional exergy analysis, because the difference between the defined fuels (resources) and products is equal to the sum between both exergy destruction and loss for each unit of the assessed cycles.

The proposed approach can be applied regardless of temperature, pressure or quality of the assessed thermodynamic state and also regardless of the thermodynamic process. For instance, when phase change takes place or when there is negative flow exergy associated to any physical flow.

If the working fluid is modeled as an incompressible liquid and the process is modeled as isenthalpic, considering one inlet and one exit for the mass flows, then the resources are both the syntropy and the flow work and the product is the internal energy. This situation takes place, e.g., when one evaluates the valve which composes the thermal compressor of an absorption chiller.

If the working fluid is modeled as an ideal gas and the process is modeled as isenthalpic, considering one inlet and one exit for the mass flows, then the applying of this alternative thermoeconomic approach cannot define a product for the unit under assessment. In other words, this is a limitation of the UFS Model.

6. ACKNOWLEDGEMENTS

Authors of this paper would like to thank the Brazilian National Agency for Petroleum, Natural Gas and Biofuels (ANP) for the financial support.

7. REFERENCES

- Çengel, Y.A. and Boles, M.A., 2006. *Thermodynamics: An Engineering Approach*. McGraw-Hill, New York.
- Erlach, B., Serra, L. and Valero, A., 1999. "Structural Theory as Standard for Thermoeconomics". *Energy Conversion and Management*, Vol. 40, pp. 1627-1649.
- Frangopoulos, C.A., 1987. "Thermo-Economic Functional Analysis and Optimization". *Energy*, Vol. 12, No. 7, pp. 563-571.
- Lourenço, A.B., Santos, J.J. and Donatelli, J.L., 2011. "Thermoeconomic Modeling of a Simple Heat Pump Cycle: An Alternative Approach for Valve Isolation". In *Proceedings of the Fifteenth Symposium on Thermal Science and Engineering of Serbia*. Sokobanja, Serbia. Pp. 446-453.
- Lozano, M.A. and Valero, A., 1993. "Thermoeconomic Analysis of a Gas Turbine Cogeneration System". In *Proceedings of the ASME-WAM*. New Orleans, Louisiana, USA. Book No. H00874, AES-Vol. 30, pp. 312-320.
- Santos, J., Nascimento, N., Lora, E. and Reyes, A.M., 2009. "On the Negentropy Application in Thermoeconomics: A Fictitious or an Exergy Component Flow?". *International Journal of Thermodynamics*, Vol. 12, No. 4, pp. 163-176.
- Torres, C., Serra, L., Valero, A. and Lozano, M.A., 1996. "The Productive Structure and Thermoeconomic Theories of System Optimization". In *Proceedings of the ASME-IMECE*. Atlanta, Georgia, USA. Book No. G01022, AES-Vol. 36, pp. 429-436.
- Torres, C., Valero, A., Rangel, V. and Zaleta, A., 2008. "On the Cost Formation Process of the Residues". *Energy*, Vol. 33, pp. 144-152.
- Tsatsaronis, G., 1987. "A Review of Exergoeconomic Methodologies". In *Proceedings of the Fourth International Symposium on Second Law Analysis of Thermal Systems*. Rome, Italy. Pp. 81-87.
- Valero, A., Serra, L. and Uche, J., 2006. "Fundamentals of Exergy Cost Accounting and Thermoeconomics. Part I: Theory". *Journal of Energy Resources Technology*, Vol. 128, pp. 1-8.
- von Spakovsky, M.R., 1994. "Application of Engineering Functional Analysis to the Analysis and Optimization of the CGAM Problem". *Energy*, Vol. 19, No. 3, pp. 343-364.

8. RESPONSIBILITY NOTICE

The authors are the only responsible for the printed material included in this paper.