

MODELING OF THE TRANSIENT THERMAL ANALYSIS OF THE HEATING OF WATER IN WASHING MACHINES

Ana C. Meinicke, kiksana@yahoo.com.br

Federal University of Santa Catarina

Rua Engenheiro Agrônomo Andrey Cristian Ferreira, 799 – Carvoeira – Florianópolis – SC, 88040-900

Fernando A. Ribas Jr., fernando_r_junior@whirlpool.com

Whirlpool Latin America

Rua Dona Francisca, 8300 Bl. 2A – Zona Industrial Norte – Joinville – SC, 89219-600

Abstract. *The reduction of energy consumption and water usage for washing machines has become more and more important. Based on that scenario, good numerical models that are capable to predict the energy and thermal dynamics of those machines are becoming more necessary. Most of the horizontal axis machines sold in the USA and Europe apply a heater to heat up the water, in order to maximize the washing performance. This heat rise process is the main responsible for the appliance energy consumption. In this sense, this study aims to develop a thermal model, using Modelica language, that predicts the water heat rise and energy consumption during the washing process. With that, it is possible to study and optimize the energy consumption of the washing machine. Experiments have been performed in order to validate the thermal model. When the numerical and experimental results are compared, it has been observed a good agreement, making the model suitable for energy and thermal studies.*

Keywords: *washing machine, energy consumption, water heating, Modelica*

1. INTRODUCTION

Hot water has been widely used for washing clothes, mainly in cold locations. Hot water is known to dilute the soap more efficiently, to facilitate the break of fat and dirt particles and to kill mites (McDonald and Tovey, 1992) and other microorganisms (Warner, 2011) present in the clothes. Washing clothes with hot water strongly increases the washing performance. However, this is a process that consumes a huge amount of energy. In order to optimize the machine energy consumption it is important to understand and model the physics behind the temperature rise of the machine.

The objective of this paper is to present an analytical model that estimates the water temperature reached during the heating phase of a horizontal washing machine washing cycle. The model is also calibrated and validated through experimental data.

2. DEVELOPMENT

The model aims to obtain the temperatures from the water and from other parts of the machine during the heating process. It is based on a horizontal axis Whirlpool machine, that can be seen in **Figure 1**.

If the model is correctly developed, it is an ideal tool to be used during the project phase of a washing machine, to verify if the dimensions and parameters, such as water volume and dissipated power of the new machine are appropriate to raise the water temperature to the desired conditions.



Figure 1. Whirlpool washing machine applied in the analysis.

2.1 Analytical model

The 1D model was developed in Modelica language (Fritzon, 2004), that is suitable for the transient analysis of physical systems. The Modelica environment applied is the open-source package OpenModelica (OSMC, 2012). The thermal network can be assembled in a visual and intuitive process (using the OpenModelica Connection Editor) and part of the code can also be developed directly in the text format. The user can also build customized libraries and load them in the system. This is what was done in the present work, where air properties evaluation and correlations for convection were developed and loaded in the numerical system.

See in Figure 2 a scheme of the network developed for this problem. It's possible to see thermal capacitance nodes, connected by conduction, convection and radiation paths. A heat flow connection is than applied to model the heater power. All the "f" components are user libraries for specific calculations (like convection coefficients) that are loaded in the Modelica environment.

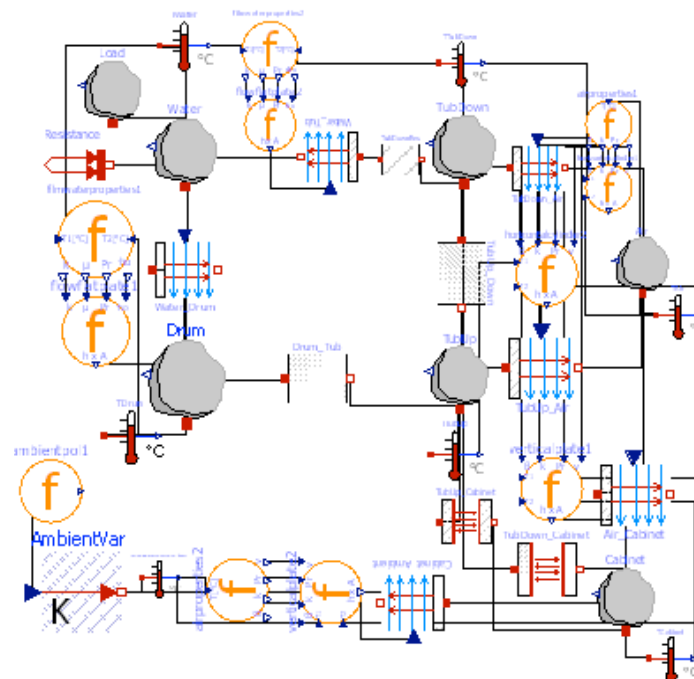

Figure 2. Thermal model of the water heat rise system developed in OpenModelica.

Entering in more details in the numerical model, several simplifications and assumptions were adopted, and later tested in the calibration and validation phase. The washing machine was simplified to water, tub, drum, air, power heater and cabinet. The internal baskets (drum and tub) were modeled as concentric cylinders and the cabinet was modeled as a parallelepiped, as can be seen in Figure 3. The real masses for the components were evaluated using the real 3D geometry, and the differences from the 1D formulation were handled through mass correction factors.

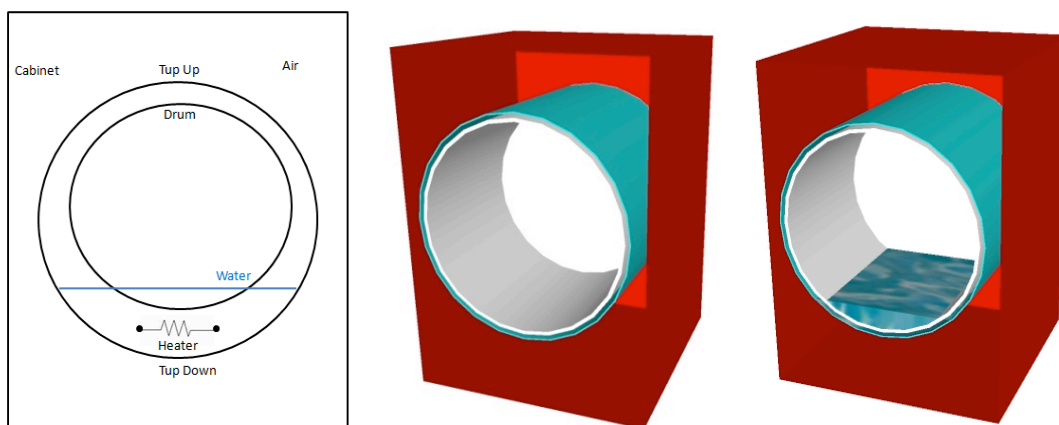

Figure 3. Simplified geometry of the washing machine with water inside.

The thermal network was built considering the physical understanding on the main important heat paths between the different components. The water absorbed by the load and the load were modeled as a homogeneous body, that exchanges heat with the inferior part of the tub and the drum by convection and that receives all the power generated by the electrical resistance (heater). The drum was modeled as a rotating homogeneous body, that exchanges heat with the water by convection and with the tub by conduction. The tub part, that is normally made of plastic, was divided in two parts. A "tub down" region in contact with the hot water, and a "tub up" region, that is the rest. The two parts exchange heat between each other by conduction, with the water and the air by convection, with the cabinet by radiation and with the drum by conduction. The air inside the machine, between the tub and the cabinet, was modeled as a homogeneous body that exchanges heat with the tub and the cabinet by convection. The cabinet was also modeled as a homogeneous body, and it exchanges heat with the air inside the machine and the ambient air by convection and with the tub by radiation. The heat path inside the machine can be seen in Figure 4.

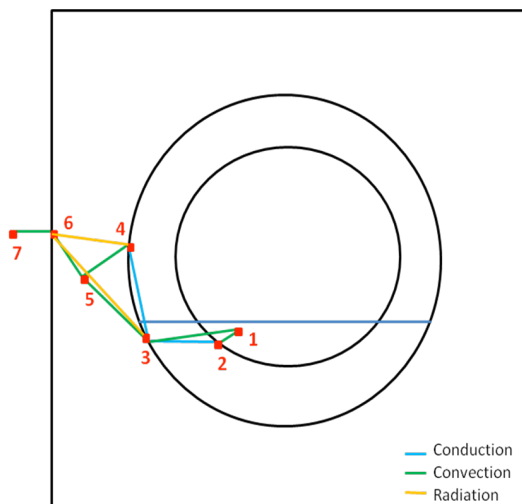

Figure 4. Heat path in the machine.

The heat exchange by convection, conduction and radiation was modeled according to Eq. 1, Eq. 2 and Eq. 3, respectively, where Q is the heat exchanged, h is the convection coefficient, A is the area, k is the conductivity, l is the length of the wall that is conducting the heat, ε is the emissivity, σ is the Stefan-Boltzmann constant, T is the temperature and 1 and 2 are two parts that exchange heat between each other. The heat accumulation on each homogeneous body was modeled according to Eq. 4, where m is the mass of the body and c_p is its specific heat.

$$Q = hA(T_1 - T_2) \quad (1)$$

$$Q = \frac{kA}{l}(T_1 - T_2) \quad (2)$$

$$Q = \varepsilon A \sigma (T_1^4 - T_2^4) \quad (3)$$

$$Q = mc_p(T - T^0) \quad (4)$$

All the convection connections between the thermal capacitances, as can be seen in Figure 5, were evaluated through the following standard heat transfer correlations found in the literature. Equation 5 calculates the Nusselt number for forced convection over horizontal flat plate (Baehr and Stephan, 2010), Eq. 6 calculates the Nusselt number for natural convection over horizontal cylinder (Churchill and Chu, 1975) and Eq. 7 calculates the Nusselt number for natural convection in vertical plate (Incropera et. al, 2007). Those correlations were adjusted by a calibration factor, after the validation with experimental data.

$$Nu_{L,nurb} = \frac{0,037 Re_L^{0,8} Pr}{1 + 2,443 Re_L^{-0,1} (Pr^{2/3} - 1)} \quad (5)$$

$$Nu = \left[0,6 + \frac{0,387 Ra^{1/6}}{\left(1 + \left(\frac{0,559}{Pr} \right)^{9/16} \right)^{8/27}} \right]^2 \quad (6)$$

$$Nu_L = 0,68 + \frac{0,67Ra_L^{1/4}}{\left(1 + \left(\frac{0,492}{Pr}\right)^{9/16}\right)^{4/9}} \quad (7)$$

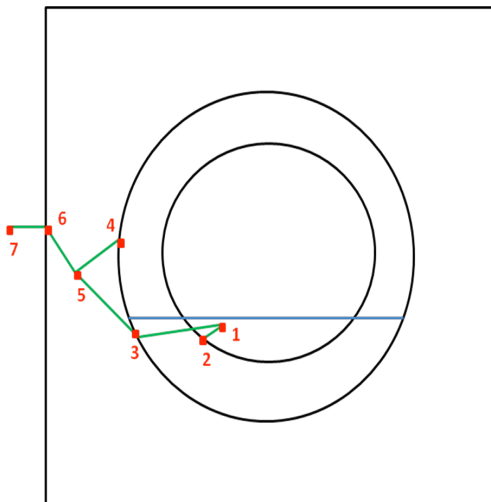

Figure 5. Convection paths in the model.

To analytically solve the problem, several parameters had to be obtained. Some of the parameters were directly measured, others had to be calculated and others were searched on the literature. The obtained parameters are water mass, load mass, absorption rate of the load, heater power, initial temperatures, machine dimensions, weights, convection coefficients, heat transfer areas, emissivity values and thermal conductivities.

2.2 Experiments

To calibrate and validate the results of the model, some experiments were conducted. The objective of the experiments was to obtain the temperatures of the water and other parts of the machine while it was performing a washing cycle. The test bench utilized can be seen in Figure 6, and was composed by a HP laptop, used to control the machine and save the data obtained, a data acquisition unit Agilent 34970A, used to obtain the temperature data from the thermocouples, and a power analyzer Fluke 43B, used to measure voltage and current on the electrical resistance. Type T thermocouples were connected to determined points in the machine that would represent the mean temperature of a body, as can also be seen in Figure 6.

The experiment consisted in filling the machine with a certain volume of water, turning the heater and the electrical motor on to rotate the drum at a certain speed. After a while, the heater is turned off.

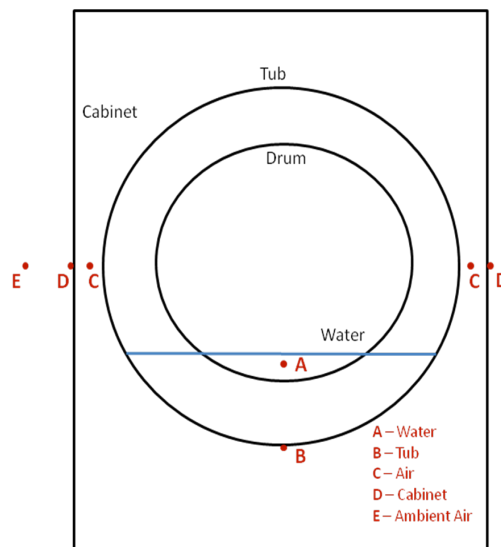

Figure 6. Test bench and the position of the thermocouples.

3. RESULTS

Several results were obtained varying the water volume, type of load and mass of load. One result is presented in Figure 7, comparing the calibrated model with the experimental data.

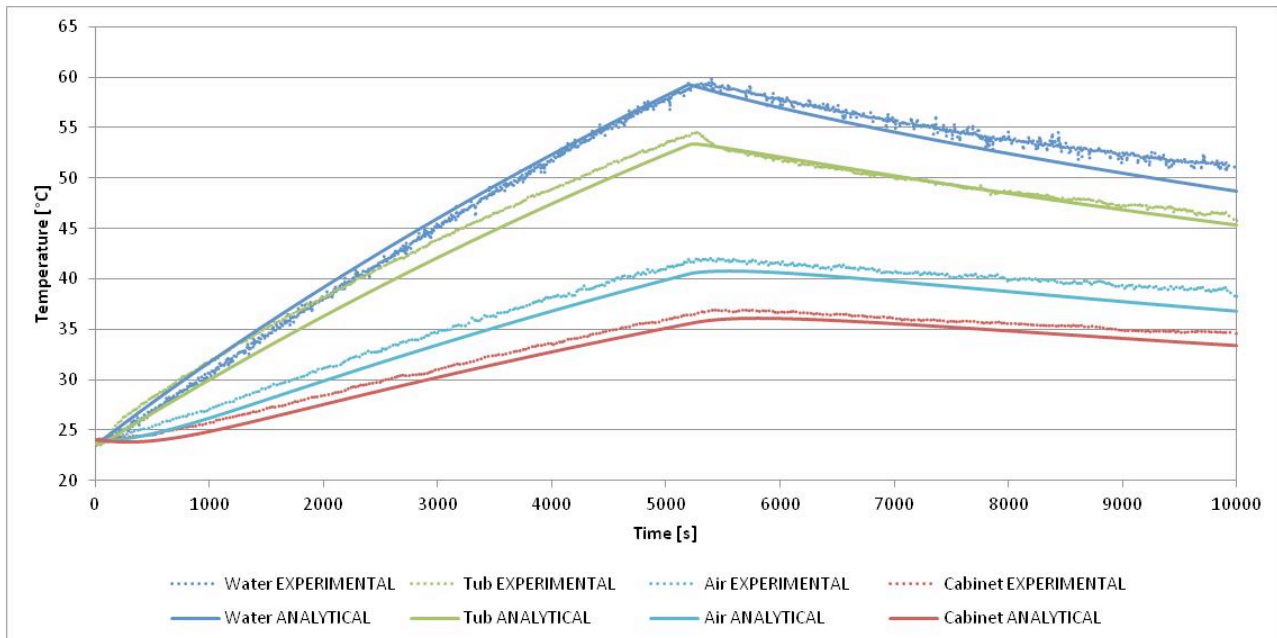

Figure 7. Comparison results (analytical and experimental) for 34 liters of water and 3.43 kg of terry towels in the washer.

Although several improvements in the model can be made, this first version is already showing a good agreement.

As next steps, the model should be stressed with other different thermal conditions, and some additional improvements already identified should be inserted in the model.

4. REFERENCES

- Baehr, H. D.; Stephan, K., 2004. Wärme- und Stoffbertragung. Springer, Germany.
- Churchill S. W.; Chu H. S., 1975. Correlation equations for laminar and turbulent free convection from a vertical plate, Int. J. Heat. Mass Transfer, Vol. 18, pp. 1323-1329.
- Fritzon, P., 2004. Principles of object oriented modeling and simulation with Modelica 2.1. Wiley-IEEE Press.
- Incropera, F. P., Dewitt, D. P., Bergman, T. L., Lavine, A. S., 2007. Introduction to Heat Transfer. John Wiley & Sons, USA.
- McDonald, L. G.; Tovey, E., 1992. The role of water temperature and laundry procedures in reducing dust mite populations and allergen content of bedding. Department of Medicine, University of Sydney, Australia.
- Open Source Modelica Consortium. 2011. OpenModelica. Available at: < <http://www.openmodelica.org/>>. Accessed on November 10th, 2011.
- Warner, J., 2011. Hot water removes allergens best. Published in May 21st, 2007. Available at: <<http://www.cbsnews.com/stories/2007/05/21/health/webmd/main2832168.shtml>>. Accessed in: August 16th, 2011.

5. RESPONSIBILITY NOTICE

The authors are the only responsible for the printed material included in this paper.