

## ANALYSIS OF OXYGEN-ENHANCED COMBUSTION OF GAS POWER CYCLE

Cristiano Frandalozo Maidana, [cristiano.maidana@ufrgs.br](mailto:cristiano.maidana@ufrgs.br)

Adriano Carotenuto, [adriano.carotenuto@terra.com.br](mailto:adriano.carotenuto@terra.com.br)

Paulo Smith Schneider, [pss@mecanica.ufrgs.br](mailto:pss@mecanica.ufrgs.br)

Universidade Federal do Rio Grande do Sul / GESTE, Rio Grande do Sul, Brasil. Fone: (+55) 51 33083931

**Abstract.** *The majority of combustion processes use air as oxidant, roughly taken as 21% O<sub>2</sub> and 79% N<sub>2</sub>, by volume. In many cases, these processes can be enhanced by using an oxidant that contains higher proportion of O<sub>2</sub> than in air. This is known as oxygen-enhanced combustion or OEC, and can bring important benefits like higher thermal efficiencies, lower exhaust gas volumes, higher heat transfer efficiency, reduction fuel consumption, reduced equipment costs and substantially pollutant emissions reduction. Within this scenario, this paper aims to investigate the influence of 21-30% oxygen concentration on the performance of a air-fired natural gas fueled power plant. This power plant operates under a Brayton cycle with modelos with the help of an air flow splitter after the compressor output in order to dose the oxygen rate of combustion and to keep the flue gas intake of the turbine at a prescribed temperature. Simulations shows that the enhancing of the oxidant stream reduced fuel consumption of about 10%, driven by higher adiabatic flame temperatures, which improves thermal and heat transfer efficiencies. A conclusion obtained is that the use of oxygen in higher proportions can be a challenge to retrofit existing air-fired natural gas power turbine cycles, because of the technological limitation of its materials with higher flame temperatures.*

**Keywords:** *Oxygen-enhanced combustion, fuel consumption, OEC, natural gas, gas turbine modeling, Brayton cycle*

### 1. INTRODUCTION

Oxygen combustion technology is one of the useful energy-saving technologies for combustion systems. On traditional combustion system, atmosphere air is the source of oxygen for the process. Although, nitrogen is an inert gas, it actually reacts at high temperatures and carries away a significant part of the energy of the reaction lowering the fuel availability. In contrast, oxygen combustion can overcome this disadvantage due to the lower nitrogen concentration involved.

Oxygen Enhanced Combustion (OEC) stands for process with ratios of O<sub>2</sub> to N<sub>2</sub> on the reactant stream higher than those found on atmospheric air streams. For a given air-fuel ratio, the amount of O<sub>2</sub> is kept constant whether the participation of N<sub>2</sub> is to be reduced by different techniques. Whenever all N<sub>2</sub> contents are avoided or eliminated from the reactant stream, the process is call oxy-fuel combustion. OEC display many advantages when compared to traditional combustion: fuel consumption reduction, higher heat transfer efficiency, lower exhaust gas volumes, higher available heat. However, the increase of the oxygen fraction in the feeding stream, leads to an augmentation on NO<sub>x</sub> emissions and higher adiabatic flame temperatures, although this corresponds roughly to only about 2% of the flue gas volume (Baukal, 1998). That last behavior compromises with the application of OEC on gas turbines, due to the limits of materials thermal resistance of about 1300 °C (Bejan et al., 1996).

From the economic point the view, high cost of oxygen production discourage widespread application of pure oxygen combustion. An alternative solution is to reduce the oxygen concentration during the application of oxygen combustion to existent conventional air/fuel burners. Economically, this method can save retrofitting and oxygen costs. However, fewer studies have explored the characteristics of low level of oxygen enrichment combustion in gas turbine cycles.

Gas turbine display modest values of thermal efficiency, and OEC processes can help improving it by reducing the exhaust gas volume, reverting the combustion available heat to the system, resulting in significant fuel consumption saving. According to Bisio et al., 2002, it can be seen that 45% of oxygen concentration in the combustion air with 1200 °C flue gases provides about 34% fuel reduction, but when the waste gas temperature is low, the oxygen enrichment of combustion air is not convenient. According to Bisio et al., 2002, the barrier to couple the oxygen in the power cycles continues to be the high cost of oxygen production in cryogenic plants, but the use of membranes technology to obtain air enriched with 30-45% oxygen may offset the costs of oxygen implementation with the fuel saving obtained.

Wu et al., 2010, studied the influence of oxygen concentration from 21 to 30% in the combustion of natural gas on the heating rate, emissions, temperature distributions and fuel consumption in the heating and furnace-temperature fixing tests. They concluded that heating rate was rapid as the oxygen was more intense as the oxygen fraction was ranged from atmospheric 21% O<sub>2</sub> up to 30% and the elapsed time to 46% for heating to 1200 °C. Another important data is that NO<sub>x</sub> emission was increased by a factor 4.4 times when the oxygen concentration was increased from 21 to 30%, meanwhile the CO<sub>2</sub> concentration increased almost linearly with the same oxygen concentration range. The most attractive gain is that the fuel consumption at 30% O<sub>2</sub> was reduced by 26.1% if compared to atmospheric concentrations (21% O<sub>2</sub>) when the furnace temperature of 1220 °C.

Horbaniuc et al., 2004, investigated the effects of oxygen concentration from 21 to 100% in the combustion of natural gas applied to supercritical steam boiler design comparing it to results of existing boiler design operating under conventional combustion (21%  $O_2$ ) in the air. They concluded that the increase on  $O_2$  fraction rises the temperature of the flue gases and in this way, the heat transfer surfaces could be reduced in 50% for 100%  $O_2$  in the oxidant.

Dumitrascu et al., 2001, studied alternatives to decrease the effects of temperature variation in the air intake compressor of a gas turbine in a cogeneration power plant, by implementing the following modifications in the system: a cooling by adiabatic humidification of the air in the intake flow section and between the compression stages; a steam injection in the outlet flow section of the combustor; together with these two measures procedures is the use of OEC until 35% of oxygen in the compressor air intake. They concluded that adiabatic humidification represents an effective cooling method (cooling of about 100°C) to diminish the required work of the compressor, and the increase of oxygen concentration in the air lead to a significant increase of the enthalpy after the combustion process.

Within this scenario, the present work analyzes how a gas turbine cycle responds to air-enrichment with oxygen concentration until 30% in volume, during an adiabatic combustion process, by using software EES ([www.fchart.com](http://www.fchart.com)) to perform model description and simulation. The analyzed variables are fuel and air flow rates, and adiabatic temperature for each concentration of  $O_2$  in the oxidant. Although the OEC process combustion leads to an increase of the gas temperature at the combustion chamber if compared to regular combustion processes, the flue gas temperature at the inlet of the expansion turbine was fixed in 1100 °C by mixing it to pressurized air stream from the compressor, due to the limit of the thermal resistance of turbine materials.

This paper aims to be a proof of concept of the OEC applied to gas turbine. As a preliminary approach, the temperature at the combustion chamber was left free to reach higher levels, compared to combustion with air. Too little attention was given to the emission products of lower concentration. These topics will be focused on further works.

## 2. CYCLE MODEL

The gas turbine cycle presented in this work is assembled by an air compressor, a combustion chamber and an expansion turbine. The combustion process, with and without oxygen enhanced, is modeled separately, and a more realistic description of mass flows and heat exchanges from the fuel to the working fluid was proposed. The proposed gas turbine cycle is depicted in Fig. (1), and for the sake of simplicity, regeneration devices were not considered.

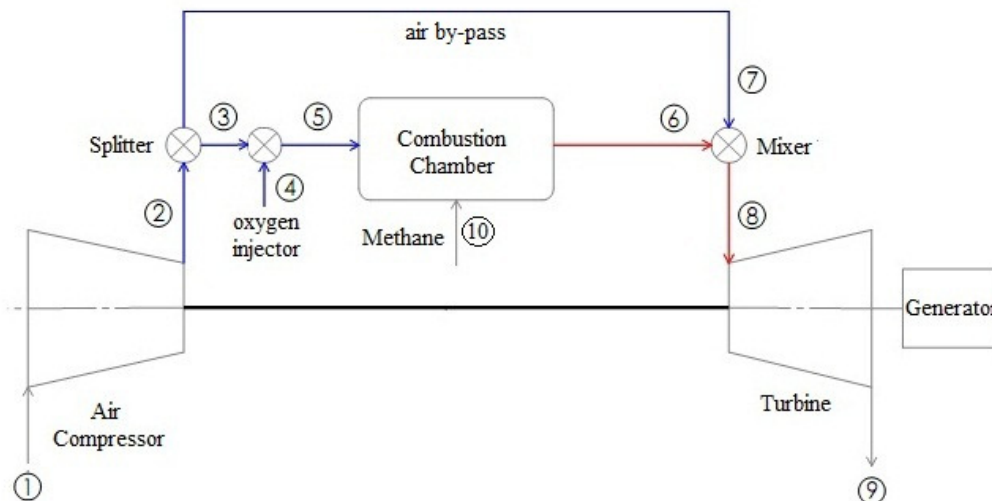

Figure 1: Proposed cycle schematics for Oxygen Enhanced Combustion (OEC)

A splitter device is placed right after the air flow stream at the output of the compressor, in order to create two separate streams with different purposes. The air stream along the path number 3 is the reactant of the combustion process that takes place at the combustion chamber. The splitter is controlled by the parameters of the desired OEC. The upper stream, number 7, drives the compressed air to a mixer, where the flue gases (point 6) are mixture and then expanded at the turbine. This procedure allows for the control of combustion process, as it cannot operate at high air/fuel ratios, and corresponds to the air by-pass of gas turbines, necessary to control the temperature of flue gases at the turbine inlet. This control circuit plays an important role for OEC as the increase on oxygen concentration of reactant stream leads to higher combustion gas temperatures. The oxygen concentration of the reactant stream (point 5) is a key parameter for the simulation of the OEC process at the combustion chamber. It starts at 21% at atmospheric conditions and will be increased up to 30% with the aid of an oxygen injector device (point 4), installed before the combustion chamber inlet. The OEC process starts by the reduction of the air flow rate, at atmospheric conditions,

along point 3. Both oxygen and nitrogen are reduced, and combustion process tends to become enriched, as the air/fuel ratio decrease. In order to supply enough oxygen to achieve a stoichiometric combustion, extra oxygen is injected at point 4. The fraction of oxygen on the feeding mixture from that point on rises, if compared to atmospheric one, but actually is the amount of nitrogen that is reduced. The enhanced-oxygen combustion acts at the nitrogen concentration, but results are displayed in terms of oxygen fraction of the reactant stream.

Pure methane ( $CH_4$ ) is taken as the fuel for the cycle, since it is the major component of natural gas. Composition of dry air is assumed, with 21%  $O_2$  and 79%  $N_2$  in volume. It is also considered that all gases behave as ideal gases, and their specific heats are a function of the process temperature.

### 3. GOVERNING EQUATIONS

Mass, species and energy balances are established for several control volume of the cycle, and are detailed as follows, with its thermodynamics states identified by numbers in the cycle schematic presentation of the Fig. (1). All process is taken in steady state.

#### 3.1. Compressor

The compressor is modeled by continuity and energy balances. Its main expression is the one for the compressor isentropic efficiency  $\eta_c$  given by Eq. (1):

$$\eta_c = \frac{\dot{W}_s}{\dot{W}_c} = \frac{\dot{n}_1 (\bar{h}_{2,s} - \bar{h}_1)}{\dot{n}_1 (\bar{h}_2 - \bar{h}_1)} \quad (1)$$

for

$$\bar{s}_1 = \bar{s}_{2,s} \quad (2)$$

Where  $\dot{W}$  is the compressor power [kW], and sub indexes  $c$  and  $s$  stands for the actual compressor and the ideal isentropic behavior, respectively. Specific enthalpy  $h$  and specific entropy  $s$  are expressed in molar basis [kJ/kmol] and [kJ/kmol K]. The specific enthalpy and entropy of the mixture is composed by specific values of each component of dry air weighted by its respective molar fractions, defined by Eq. (3) and Eq. (4):

$$\bar{h}_1 = \sum_{i=1}^k x_k \bar{h}_k \quad (3)$$

$$\bar{s} = \sum_{i=1}^k x_k \bar{s}_k \quad (4)$$

where  $x_k$  is the molar fraction of the  $k$  number of components in the oxidant.

The continuity equation is written as:

$$\dot{n}_1 - \dot{n}_2 = 0 \quad (5)$$

where,  $\dot{n}$  is the air molar flow rate [kmol/s]. The energy balance is given by Eq. (6):

$$\dot{n}_1 (\bar{h}_2 - \bar{h}_1) - \dot{W}_c = 0 \quad (6)$$

#### 3.2. Splitter

In the splitter, the total air flow coming from the compressor is partially deviated in two different paths, according to following process prescriptions: the air flow rate demanded by the mixer to keep the inlet turbine flue gas temperature fixed (in the present work set in 1100 °C) and the equivalence ratio  $\phi$  at the combustion chamber. The equations for this device, from Eq. (7) to Eq. (9), are presented below:

$$\dot{n}_3 = y \dot{n}_2 \quad (7)$$

$$\dot{n}_7 = (1 - y)\dot{n}_2 \quad (8)$$

$$\dot{n}_2 \bar{h}_2 - (\dot{n}_3 \bar{h}_3 + \dot{n}_7 \bar{h}_7) = 0 \quad (9)$$

where  $y$  is the fraction of air flow rate coming from the compressed and that flows across the combustion chamber path.

All the specific enthalpies of the streams 2, 3 and 7 have the same composition of the atmosphere dry air, taken 21%  $O_2$  and 79%  $N_2$ . The variation of oxygen concentration in the oxidant occurs only after point 5, at the oxygen injector.

### 3.3. Combustion chamber

The stoichiometric combustion of methane with air may be represented by the simplified global equation:



From Eq. (10), it may be seen that nearly 70% of exhaust gases volume is  $N_2$ . According to Baukal et al., 1998, the stoichiometric combustion with oxygen may be represented by the Eq. (11), where the increase of oxygen volume in the oxidant results in a reduction of nitrogen volume, representing by number of moles ( $z$ ):



where  $0 \leq z \leq 7.52$ , depending on the volume of the oxygen.

The present work models the combustion chemical reaction following the products and reagents of Eq. (11), and for the seek of simplicity,  $NO_x$  and other low concentration species were disconsidered and be object of further investigations, since  $NO_x$  emissions correspond roughly about 2% of the flue gas volume (Baukal, 1998) with 30% oxygen concentration in the oxidant for stoichiometric combustion. The combustion process was taken as adiabatic and occurs under constant pressure, provided by compressor outlet pressure  $p_2$ .

All the species of the combustion products obtained with the increase of oxygen concentration in the oxidant may be calculated with high accuracy by using NASA computer program - CEA (Chemical Equilibrium with Applications) developed by Gordon and McBride, 1994. This software is well validated within the scientific community and it's based on the minimization of the Gibbs Free Energy of a gaseous system. An equilibrium process or the minimization of free energy means that there is an infinite amount of time for the chemical reaction takes place or that the reaction products are not limited by the chemical kinetics, which it's a good assumption, since the combustion reaction of gases are completed in fractions of a second.

The equivalence ratio  $\phi$ , which is commonly used to indicate quantitatively whether a fuel-oxidizer mixture is rich, lean, or stoichiometric (Turns, 2000), is defined by the following equation:

$$\phi = \frac{(F/A)}{(F/A)_{stoic}} \quad (12)$$

where  $F$  and  $A$  represent the amount of fuel and air respectively, and can be both expressed in mass or molar basis. For the present work, the equivalence ratio  $\phi$  is taken as 1, meaning that the fuel-oxidizer mixture is stoichiometric, for any oxygen to nitrogen ratio of the oxidant. Although higher values of flue gas temperature (stream 6) can be reached with the increase of oxygen concentration until 30%, compared to the regular combustion process (i.e. with  $\phi$  lesser than 1 and the air as oxidant), the present work aims to be a proof of concept, investigating the benefits provided by Oxygen Enhanced Combustion (OEC), as the fuel consumption reduction, leaving apart the staged combustion modeling to reduce the flue gas temperature in the combustion chamber; this modeling will be subject for further works. Due to the thermal resistance limit of turbine materials, in the expansion turbine it's simulated a blending of the flue gas with pressurized air coming from the compressor (stream 7), by fixing the flue gas temperature at 1100 °C in the mixer. The flue gas temperature (stream 8) will be limited by the correct operation of the mixer. As the total air flow rate  $\dot{n}_1$  is determined in the simulation according to the net power output from the Eq. (33), it's necessary to apply the species conservation equation for all components of the reaction in order to calculate the molar flow rates of each one of them. The Eq. (11) may be rewritten as follow in Eq. (13), keeping the stoichiometric fuel-oxidizer relation:

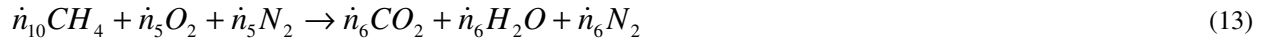

Balancing the carbon, hydrogen, oxygen, and nitrogen, the molar flow rates of the components of the reaction are represented by the Eq.(14) to Eq.(17):

From hydrogen balance species:

$$\dot{n}_{6,H_2O} = 2\dot{n}_{10} \quad (14)$$

From carbon balance species:

$$\dot{n}_{6,CO_2} = \dot{n}_{10} \quad (15)$$

From oxygen balance species:

$$\dot{n}_{5,O_2} = 2\dot{n}_{10} \quad (16)$$

From nitrogen balance species:

$$\dot{n}_{5,N_2} = \dot{n}_{6,N_2} \quad (17)$$

The global mass conservation equation applied to the combustion chamber takes into account all the molar flow rates of the components of the reaction, including reagents and products, and may be expressed by the Eq. (18).

$$\dot{n}_5 + \dot{n}_{10} - \dot{n}_6 = 0 \quad (18)$$

The adiabatic combustion is defined by the Eq. (19), where the total enthalpy of the reagents  $H_R$  must be equal to total enthalpy of the products  $H_P$  to calculate the adiabatic temperature.

$$H_R = H_P \quad (19)$$

$$H_R = \dot{n}_5\bar{h}_5 + \dot{n}_{10}\bar{h}_{10} \quad (20)$$

$$H_P = \dot{n}_6\bar{h}_6 \quad (21)$$

The specific enthalpy is given by Eq.(22):

$$\bar{h}_n = \sum_{i=1}^k x_k \bar{h}_k^o + \sum_{i=1}^k x_k \Delta\bar{h}_k \quad (22)$$

where  $\bar{h}_k^o$  and  $\Delta\bar{h}_k$  represent respectively the specific enthalpy of formation ( $T_o = 25$  °C,  $P_o = 1$  atm) and the variation of specific enthalpy with the increase of temperature of each component  $k$  of the stream  $i$ .

$$\dot{n}_5 \left( \sum_{i=1}^k x_k \bar{h}_k^o + \sum_{i=1}^k x_k \Delta\bar{h}_k \right)_{oxidant} + \dot{n}_{10} \left( \sum_{i=1}^k x_k \bar{h}_k^o + \sum_{i=1}^k x_k \Delta\bar{h}_k \right)_{fuel} = \dot{n}_6 \left( \sum_{i=1}^k x_k \bar{h}_k^o + \sum_{i=1}^k x_k \Delta\bar{h}_k \right)_{products} \quad (23)$$

### 3.4. Oxygen injector

At this position of the cycle (point 4), pure oxygen is injected in stream 3 and its demand is determined by the air-enrichment with oxygen in the stream 5. Balances equations are presented as following Eq.(24) to Eq.(26):

$$\dot{n}_3 + \dot{n}_4 - \dot{n}_5 = 0 \quad (24)$$

$$\dot{n}_i = \sum_{i=1}^k x_k \dot{n}_i \quad (25)$$

$$\bar{h}_3 \dot{n}_3 + \bar{h}_4 \dot{n}_4 - \bar{h}_5 \dot{n}_5 = 0 \quad (26)$$

where  $i$  is the stream number.

### 3.5. Mixer

The mixer is used to maintain a prescribed of the turbine inlet flue gases, fixed in present work at 1100 °C. In this point of the cycle, the system of equations is used together with the equations of the air splitter, where the energy conservation equation Eq. (28) is used to calculate the fraction of air flow rate  $y$ . The equations this device are represented by the following equations:

$$\dot{n}_6 + \dot{n}_7 - \dot{n}_8 = 0 \quad (27)$$

$$\dot{n}_6 \bar{h}_6 + \dot{n}_7 \bar{h}_7 - \dot{n}_8 \bar{h}_8 = 0 \quad (28)$$

### 3.6. Turbine

As well as the compressor, the turbine is modeled with isentropic efficiency equation and some auxiliary conservation equations to calculate the specific enthalpy in the turbine outlet:

$$\eta_t = \frac{\dot{W}_t}{\dot{W}_s} = \frac{\dot{n}_8 (\bar{h}_8 - \bar{h}_9)}{\dot{n}_8 (\bar{h}_9 - \bar{h}_{9,s})} \quad (29)$$

where  $\eta_t$  is the turbine isentropic efficiency and  $\dot{W}_t$  is the work of the turbine [kW].

Similarly to the compressor modeling:

$$\dot{n}_8 - \dot{n}_9 = 0 \quad (30)$$

$$\dot{m}_7 (h_6 - h_7) - \dot{W}_t = 0 \quad (31)$$

$$\bar{s}_8 = \bar{s}_{9,s} \quad (32)$$

where  $\bar{s}_{9,s}$  is the entropy in the isentropic expansion [kJ/kmol.K]:

The net power output obtained in the cycle is calculated by the Eq. (33), as follow:

$$\dot{W}_{net} = \dot{W}_t - \dot{W}_c \quad (33)$$

## 4. SIMULATION OF OEC CYCLE:

The cases analyzed in the simulation of the gas turbine cycle are based on the variation of the oxygen concentration of air stream entering in the combustion chamber, starting from 21% until 30% of O<sub>2</sub> concentration, and it is considered a parameter of the simulation.

The assumptions underlying the gas turbine cycle for all the cases analyzed include the following:

- The power cycle operates at steady state;
- The ideal-gas mixtures principles apply for the air and the combustion products;
- The fuel (natural gas) is taken as 100% methane modeled as an ideal gas;
- The oxidant is composed by dry air with O<sub>2</sub> and N<sub>2</sub>;

- The combustion in the combustion chamber is complete and adiabatic.  $N_2$  is inert;
- All the equipments operate without heat and pressure losses.

The parameters of the simulation are listed in Tab. 1 for all the cases analyzed, segregated by equipment. The net power output for all the simulations is 30 MW.

Table 1. Simulation parameters	
Air Compressor $T_1 = 298.15 \text{ K (} 25 \text{ }^\circ\text{C)}, p_1 = 1,013 \text{ bars (1 atm)}$ Air molar analysis: 21% $O_2$ and 79% $N_2$ Pressure ratio: $p_2/p_1 = 10, \eta_c = 0.6$	Splitter Air molar analysis: 21% $O_2$ and 79% $N_2$ in streams 3 and 7, $p_2 = 10.13 \text{ bars}$
Oxygen injector 100% $O_2$ in stream 4, $T_4 = T_2$	Combustion Chamber $p_6 = 10.13 \text{ bars}, T_{10} = 298.15 \text{ K}, \phi = 1$
Mixer $T_8 = 1373.15 \text{ K (} 1100 \text{ }^\circ\text{C)}$	Turbine $\eta_t = 0.8$

The variables of the system include the molar flow rates of the air, combustion products, and fuel, the power required by the compressor, the power developed by turbine, and the following specific enthalpies and temperatures, as presented in Tab. 2, segregated by equipment.

Table 2. Simulation variables	
Air Compressor $T_2, T_{2,s}, \bar{h}_2, \bar{h}_{2,s}, \dot{n}_1, \dot{W}_c$	Splitter $\dot{n}_3, \dot{n}_7$
Oxygen injector $\dot{n}_4, \dot{n}_5$	Combustion Chamber $T_6, \dot{n}_6, \dot{n}_{10}$
Mixer $\dot{n}_8, y$	Turbine $T_9, T_{9,s}, \bar{h}_9, \bar{h}_{9,s}, \dot{W}_t$

#### 4. RESULTS AND DISCUSSIONS

The complete set of equations was simulated by the Engineering Equation Solver (EES) presented as follows. All indexed quantities are related to points presented at Fig. (1).

Figure 2 shows the reduction of fuel (methane) with increasing oxygen concentration of the input stream of oxidant into the combustion chamber:

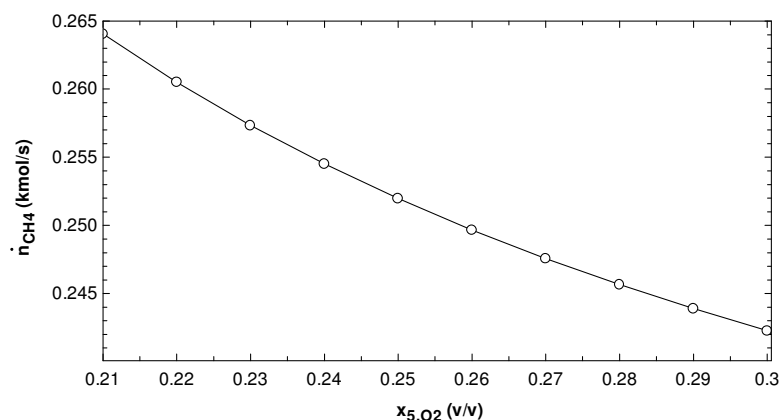

Figure 2. Fuel consumption as a function of molar fraction of oxygen in the stream of oxidizer, for an adiabatic and stoichiometric combustion of methane

Figure 3 shows the molar flow rate fraction of atmospheric air that flows throughout point 3, right after the splitter, as a function of oxygen concentration. The reduction of this molar flow rate (stream 3) is responsible for the nitrogen reduction of the air flow rate intake for the combustion process.

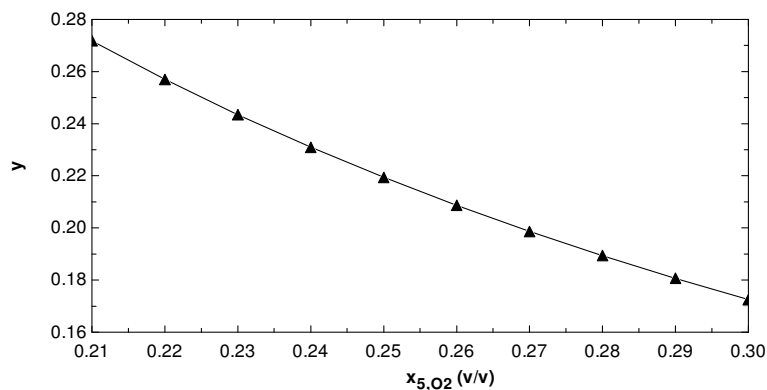

Figure 3. Air flow rate fraction through point 3 vs. concentration of oxygen admitted into the combustion chamber. Results for an adiabatic and stoichiometric combustion of methane

As a result of the reduction of the air flow rate intake at point 3, displayed on the last figure, an addition of pure oxygen flow rate is needed in order to keep the combustion process at stoichiometric condition, and Fig. (4) shows the correspondent molar flow rate of pure oxygen at point 4 ( $\dot{n}_4$ ).

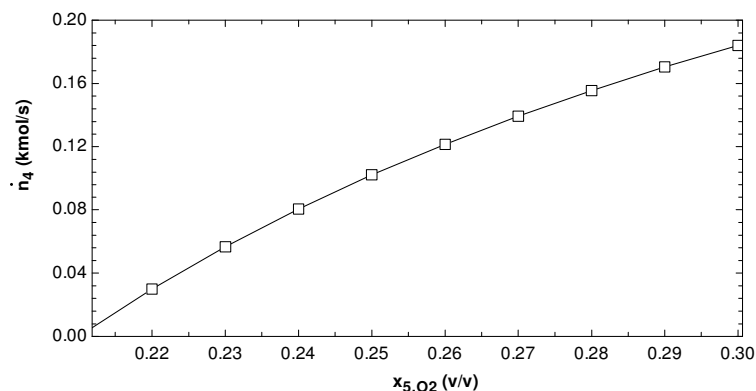

Figure 4. Molar flow rate of oxygen delivered by the injector vs. molar fraction of oxygen at the entrance of the combustion chamber for an adiabatic and stoichiometric combustion of methane

The enhanced oxygen combustion leads to a net reduction of nitrogen flow rate, showed at Fig. (5), starting at about 2.0 kmol/s when the oxygen is at atmospheric concentration and reduced to approximately 1.1 kmol/s at the end of the simulated range.

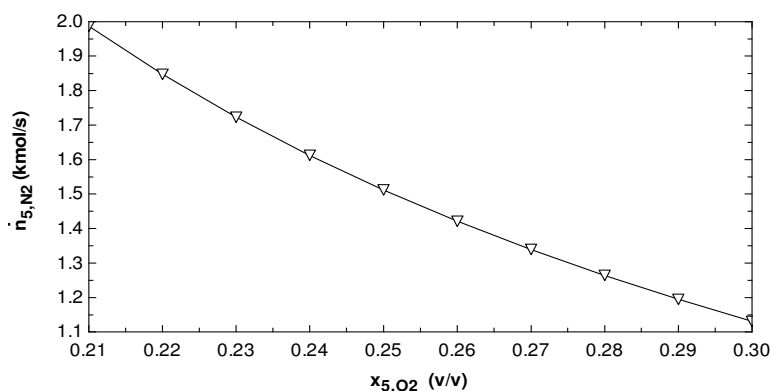

Figure 5. Molar flow rate of nitrogen through the combustion chamber for an adiabatic and stoichiometric combustion of methane as a function of oxygen

Results presented on the previous figures show that a reduction on air flow rate admitted at atmospheric concentration (point 3) is followed by an increase of injected pure oxygen, keeping  $\phi=1$  in the combustion chamber.



As expected, there was a reduction in the flow rate of nitrogen through point 5. Figure 6 shows the reduction on the flow rate of products due to the reduction of the molar flow rate of natural gas (methane) and nitrogen in the oxidant.

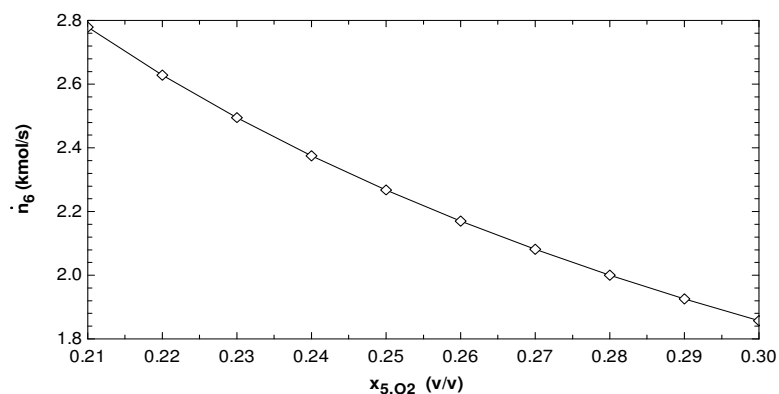

Figure 6. Molar flow rate of combustion gases vs. oxidizer composition at the entrance of the combustion chamber for an adiabatic and stoichiometric combustion of methane

Figure 7 shows the increase in temperature of the flue gases as a function of the increase of oxygen concentration at point 5, as expected:

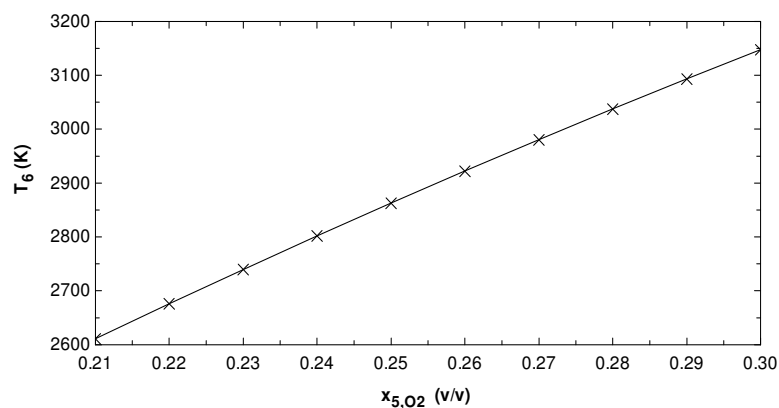

Figure 7. Adiabatic flame temperature obtained for an adiabatic and stoichiometric combustion as a function of the oxygen concentration

Figure 8 shows the change in net specific work of the cycle  $w_{net}$ , defined as the ratio between net power and molar flow rate of fuel. The increase in  $w_{net}$  is justified by the reduction of fuel consumption, as shows in Fig. (2), with the increase of oxygen concentration in point 5.

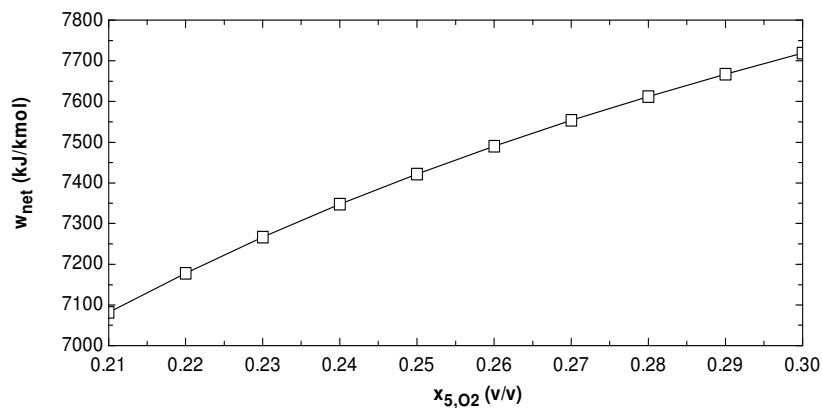

Figure 8. Increase in specific net work (in kJ per kmol of fuel) vs. the oxygen concentration in point 5 for an adiabatic combustion and stoichiometric

## 5. CONCLUSIONS

In this work, a gas turbine cycle was modeled and simulated with a special attention to the description of the combustion process within the combustion chamber and the auxiliary flow paths, needed to represent a more realistic enhanced oxygen combustion (OEC) process. Results showed a reduction of up to 8.25% of fuel consumption on OEC compared to base case, i.e., oxidizer at atmospheric composition with  $\phi$  equal to 1. A reduction on the flue gas formation up to 33.2% in volume was also calculated. However, there was a need to supply pure oxygen (stream 4) of up to 0.20 kmol/s when reaching an oxygen concentration of 30% at the combustion chamber intake.

The simulated values for the adiabatic flame temperature and combustion products were close to those obtained by NASA computer program - CEA. Results displayed at Fig. (7) show a large increase in the gas temperature in the combustion chamber for increasing values of  $O_2$  in oxidizer, suggesting that thermal resistance limits of the turbine and combustion chamber materials can be a technological challenge in this application. As a next step for this research, it has been already identified the need for the investigation of the species with lower concentrations produced by the combustion of methane and its effects on the cycle fuel consumption, along with an analysis of the variation in concentration of some pollutants, as  $NO_x$  and  $CO$  emissions, under OEC processes. In addition, an exergetic analysis of the cycle and a study of the energy required for oxygen production should be evaluated.

## 6. ACKNOWLEDGEMENTS

The authors thank CNPQ due to the financial support by means of a Masters Degree scholarship, a Doctor Degree scholarship and a research grant, respectively, to Mineral Coal Net (from CNPQ) and CAPES/PROBAL/Processes/n°348-10.

## 7. REFERENCES

- Baukal, C.E., 1998. "Oxygen Enhanced Combustion". Ed. CRC Press LLC, Florida, USA, 356 p.
- Bejan, A., Tsatsaronis, G., Moran, M., 1996. "Thermal Design and Optimization". Ed. John Wiley & Sons, Inc., USA, 542 p.
- Bisio, G., Bosio, A., Rubatto, G., 2002. "Thermodynamics applied to oxygen enrichment of combustion air". Energy Conversion and Management 43, 2589-2600.
- Gordon, S., McBride B., J., 1994. "CEA: Computer Program for Calculation of Complex Chemical Equilibrium Compositions and Applications". NASA Reference Publication – 1311, Cleveland, Ohio, USA, 61 p.
- Horbaniuc, B., Marin, O., Dumitrascu, G., Charon, O., 2004. "Oxygen-enriched combustion in supercritical steam boilers". Energy 29, 427-448.
- Horbaniuc, B., Marin, O., Dumitrascu, G., Charon, O., 2001. "The influence of the compression interstage cooling by adiabatic humidification of the steam injection and of the oxygen enriched combustion upon the gas turbine co-generation systems". 2<sup>nd</sup> Heat Powered Cycles Conference Conservatoire national des arts et métiers, Paris.
- Turns, S.R., 2000. "An Introduction to Combustion: Concepts and Applications". Ed. McGraw-Hill, Singapore, 700 p.
- Wu, K., Chang, Y., Chen, C., Chen, Y., 2010. "High-efficiency combustion of natural gas with 21-30% oxygen-enriched air". Fuel (article in press).

## 8. RESPONSIBILITY NOTICE

The authors are the only responsible for the printed material included in this paper.