

## VIBRO-ACOUSTIC ANALYSIS OF THE BRAZILIAN SATELLITE LAUNCHER FAIRING, USING SEA

### Rogério Pirk

Centro Técnico Aeroespacial (CTA)/Instituto de Aeronáutica e Espaço (IAE)  
e-mail: [rogerio.pirk@iae.cta.br](mailto:rogerio.pirk@iae.cta.br)

### Luiz Carlos Sandoval Góes

Centro Técnico Aeroespacial (CTA)/Instituto de Tecnológico de Aeronáutica (ITA)  
e-mail: [goes@ita.br](mailto:goes@ita.br)

### Paul Sas

Katholieke Universiteit Leuven  
e-mail: [paul.sas@mech.kuleuven.ac.be](mailto:paul.sas@mech.kuleuven.ac.be)

### Wim Desmet

Katholieke Universiteit Leuven  
e-mail: [wim.desmet@mech.kuleuven.ac.be](mailto:wim.desmet@mech.kuleuven.ac.be)

**Abstract.** *The vibro-acoustic response of the fairing of the Vehicle Satellite Launcher (VLS) is obtained, using the Statistical Energy Analysis Technique (SEA). The SEA virtual prototype of the referred fairing is built up, applying the estimated acoustic loading (160 OSPL), during the lift off. The structural and acoustic subsystems are connected and the approaches of this high frequency analysis technique are described. 1/3 octave band analysis is run and the results, as well as some comments about the uncertainties of this technique in low frequency band analysis are described.*

**Keywords:** *Vibro-acoustic, Statistical Energy Analysis (SEA), Vehicle Satellite Launcher (VLS), Fairing*

### 1. Introduction

During flight missions, space vehicles are subjected to severe dynamic pressure loading when their rocket-propulsion systems are operated. This loading may be critical for the vehicle components, as well as for the payload such as satellites, which are usually very soft structures. The success of a satellite launching is determined, amongst other measures, by the satellite resistance to the fairing internal acoustic pressure.

Studies have been showing that the most critical instants during a rocket launching, in terms of acoustic solicitation, are those where the lift off, transonic flight and maximum dynamic pressure phases submit the fairing to extreme acoustic pressure levels. However, the estimated pressure levels at the lift off phase must be considered for effect of calculations. The fairing is a very important component of a launcher, where in this compartment is the payload, which shall be put in orbit. Satellites are built up, generally speaking, as soft structures controlled by electronic components, which may be very sensitive to high-level vibration and acoustic loads. The existence of fairly large and lightweight aerospace structures, and their attendant high frequency broadband loads, has meant much more attention being paid to higher order modal analysis for the purposes of predicting equipment failure and noise production. Different methods and techniques are used to estimate the inner fairing acoustic environment, when submitted to such excitations. Depending on the nature of the excitation, pressure levels and frequency range analysis, one can apply them. The well known, called deterministic methods, as Finite Elements (FE) and Boundary Elements (BE) are very powerful tools to estimate acoustic pressure into an acoustic cavity in low frequency. Due to the high level nature of the excitation loads during launchings and supposed low rigidity of a fairing structure, one may use a coupled fluid-structure model to estimate acoustic parameters. Meanwhile, FE and BE methods present limitations when analysts want to go further in frequency analysis, since for higher frequencies deterministic models may present smaller wavelengths and consequently may have increased the number of nodes and elements. This mesh refinement imposes limitations, since the amount of allocated memory and processing time become prohibitive, mainly when coupled calculations are done.

As an alternative technique for higher frequency analysis of the inner cavity of the VLS fairing, statistical approach is applied. This approach is a description of the vibration system as a member of a statistical population or ensemble, whether or not the temporal behavior is random, called SEA.

This work describes the SEA technique as an alternative for high frequency vibro-acoustic analysis of the fluid-structure dynamic system that represent the fairing of the VLS. As such, the SEA vibro-acoustic model of the fairing is built up and the analysis up to 8,000 Hz is run for 1/3 octave band, using the code LMS-SEADS. The structural and acoustic responses of the fairing are obtained, applying the estimated lift off acoustic load of 160 dB (OSPL) and some considerations about the results and the uncertainties of the SEA technique are made.

## 2. Modelling Methodology

### 2.1. Statistical Energy Analysis (SEA)

The computational efforts involved with deterministic techniques, such as FE (Zienkiewicz, 1977), and BE (Desmet and Vandepite, 2000) methods, put a severe restriction to their use for high-frequency analysis. In addition, a characteristic of high-frequency analysis is the uncertainty in modal parameters. The resonance frequencies and mode shapes show great sensitivity to small variations of geometry, construction and material properties. In light of these uncertainties, it is more appropriate for high-frequency modeling to consider a (large) population of nominally identical systems and to provide information on the ensemble-averaged dynamic response (and the associated confidence levels), as is done in Statistical Energy Analysis (SEA) (Lyon and DeJong, 1995). In this technique, complex vibro-acoustic systems are modeled as a composition of (weakly coupled) subsystems. The dynamic system response is described in terms of the frequency- and space-averaged energy response levels for each subsystem. These subsystem energy levels result from an SEA model that expresses energy balances for the various subsystems.

SEA technique is based on flow energy involving subsystems, where it is done the balance of energy.

$$\Pi_{in} = \Pi_{out} + \Pi_{diss} \quad (1)$$

where,  $\Pi_{in}$  corresponds the inner energy flow of the subsystem,  $\Pi_{out}$  is the output transmitted flow and  $\Pi_{diss}$ , is the dissipated flow.

Figure 1 shows a 4DOF SEA model, where the SEA parameters must be taken into account to do the energy balance.

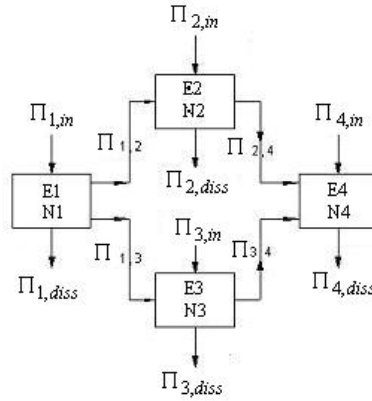

Figure 1: energy flow of a SEA model

$\Pi_{diss}$ , of each subsystem corresponds to the dissipated energy and depends on the stored energy in each subsystem. This energy is usually dissipated by friction or by the damping characteristics of the material and by acoustic radiation.

The dissipated energy ( $\Pi_{diss}$ ) can be computed by the eq. (2).

$$\Pi_{diss} = 2\pi f n_1 E_1 \quad (2)$$

where,  $E_1$ : total dynamic energy of a subsystem;  $f$ : frequency (Hz);  $n_1$ : damping loss factor.

Two formulations can be used to calculate the transferred energy of a subsystem to another, as describes De Langhe, 1998. On one hand the mean square velocity.

$$E = m \langle V_{rms}^2 \rangle \quad (3)$$

on the other hand, by the mean square pressure (eq.(4)),

$$E = \frac{v}{\rho c^2} \langle p_{rms}^2 \rangle \quad (4)$$

where;  $\langle V_{rms}^2 \rangle$ : mean square velocity;  $v$ : volume;  $\langle p_{rms}^2 \rangle$ : mean square sound pressure.

$\Pi_{out}$ , corresponds to the energy exchange between two subsystem. It is important to mention that all the treated energy quantities are mean values in the time. The transmitted power depends on the balance of the modal energy between subsystems as well as the coupling factor between them.

The transmitted energy between the system  $i$  and the subsystem  $j$  can be computed by the eq. (5), which shows that the energy flow is proportional to the internal energy of the subsystem.

$$\Pi_{i,j} = 2\pi \Delta f \beta_{ij} (\varepsilon_i - \varepsilon_j) \quad (5)$$

where,  $\varepsilon_i$  and  $\varepsilon_j$  : modal density ( $\varepsilon = E/N$ );  $N$  : number of modes;  $\Delta f$  : frequency band;  $\beta_{ji}$  : coupling factor

Substituting  $\varepsilon_i$  and  $\varepsilon_j$  in eq. (5),

$$\Pi_{i,j} = 2\pi f (\eta_{ij} E_j - \eta_{ji} E_i) \quad (6)$$

As such, the flow energy equation for the subsystems  $i$  and  $j$  corresponds to eq. (7) and (8).

$$\Pi_{i,in} = \Pi_{i,diss} + \Pi_{i,j} = 2\pi f (\eta_i + \eta_{ij}) E_i - 2\pi f \eta_{ji} E_j \quad (7)$$

$$\Pi_{j,in} = \Pi_{j,diss} + \Pi_{ji} = -2\pi f \eta_{ij} E_i + 2\pi f (\eta_j + \eta_{ji}) E_j \quad (8)$$

This formulation can be written in the matrix form, as eq. (9), which is applied for dynamic complex systems.

$$\begin{bmatrix} P_1 \\ P_2 \\ \vdots \\ P_n \end{bmatrix} = \omega [L] \begin{bmatrix} E_1 \\ E_2 \\ \vdots \\ E_n \end{bmatrix} = \omega \begin{bmatrix} \sum_{i=1}^n \eta_{1i} & -\eta_{21} & \dots & -\eta_{n1} \\ -\eta_{12} & \sum_{i=1}^n \eta_{2i} & \dots & -\eta_{n2} \\ \vdots & \vdots & \ddots & \vdots \\ -\eta_{1n} & -\eta_{2n} & \dots & \sum_{i=1}^n \eta_{ni} \end{bmatrix} \begin{bmatrix} E_1 \\ E_2 \\ \vdots \\ E_n \end{bmatrix} \quad (9)$$

where  $E_i$  ( $i=1..n$ ) is the time-averaged energy of subsystem  $i$  in the considered frequency band with center frequency  $\omega$  and where  $P_i$  ( $i=1..n$ ) is the time-averaged input power into subsystem  $i$  in that frequency band. The coefficients in the  $(n \times n)$  total loss factor matrix  $[L]$  are related to the internal loss factors  $\eta_{ii}$  ( $i=1..n$ ) of the subsystems and to the coupling loss factors  $\eta_{ij}$  ( $i,j=1..n, i \neq j$ ) between the various subsystems.

In contrast with the element based or deterministic methods, the size and subsequent computational effort of an SEA model are very small. Moreover, it is quite fair to assume that the frequency- and space-averaged results (for complex vibro-acoustic systems) give adequate information on the ensemble-averaged results.

## 2.2. SEA vibro-acoustic fairing model

Using LMS-SEADS code and applying some elements as plates, ribs and acoustic volume make the generation of the SEA fairing structural model. Structural model is built up considering the aluminium shells and the reinforcing beams as simple beams and rib-stiffened plates. Some different aluminium characteristic materials are created, since density can vary from one element to another. Table N° 1 presents the adopted materials, as well as a combined aluminum/cork material (for blanket cork simulation).

parameter\element	material 1	material 2	material 3
material	aluminum alloy	aluminum	aluminum/cork
elastic modulus (E)	7.20 E <sup>10</sup>	7.20 E <sup>10</sup>	7.20 E <sup>10</sup>
poisson ratio (ν)	0.29	0.29	0.29
density (ρ)	7000	2750	15052.57
shear modulus (τ)	2.80 E <sup>10</sup>	2.80 E <sup>10</sup>	2.80 E <sup>10</sup>
thermal expansion coefficient (T)	1.17 E <sup>-05</sup>	1.17 E <sup>-05</sup>	1.17 E <sup>-05</sup>

material 1: assigned to beams

material 2: assigned to surface 1

material 3: assigned to surfaces 2,3 and 4

Table N° 1: adopted materials of the fairing structural model

The VLS fairing is illustrated in Fig. 2. Dividing it into four surfaces, as shown in Fig. 3, generated the model of the fairing body. The SEA structural model considers connected plates and beams (edge, longitudinal and circular). On the

one hand, conical surfaces 2 and 4 are modelled with 16 connected trapezoidal plates. On the other hand, cylindrical surfaces 1 and 3 are modelled as 16 rectangular plates, connected to each other.

Surfaces 2, 3 and 4 are modelled as rib-stiffened plates comprising circumferential stiffeners (Cbeam). Between each rib-stiffened plate, a longitudinal simple beam (Lbeam) is assigned to represent the axial stiffeners. Circumferential beams (Ebeam) are assigned along the edges of the various rib-stiffened surfaces. The structural model has 176 elements (16 simple plates, 48 rib-stiffened plates, 64 longitudinal beams and 48 edge beams). Only the inertial effects of the cork lining, attached to the exterior of surfaces 2, 3 and 4, have been taken into account by defining a combined equivalent aluminium/cork density for the structural surface components.



Figure 2: general view of the VLS fairing

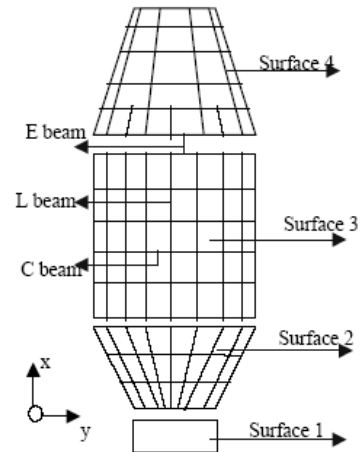

Figure 3: SEA structural model

The acoustic cavity of the fairing is modelled as a single 3-D acoustic volume ( $2.86 \text{ m}^3$ ), filled with air. This acoustic volume is connected to the surfaces of the structural model by using area connections, available in the LMS-SEADS library. As such, the coupled fluid-structure subsystems can be generated. The fairing volume 3D model is built up considering the air characteristics. Table N° 2 presents the adopted air parameters to be considered in the model.

parameter\fluid	air
sound velocity	340 m/s
mass density	$1.225 \text{ kg/m}^3$

Table N° 2: fluid parameters

All the 177 elements (176 structural and 1 acoustic elements) of the complete SEA fairing model are connected with line type connections (plate-plate connections, plate-Ebeam and plate-Lbeam connections) and point type connections (connections beam-beam). The connection between the plates and the acoustic volume are provided by area type connections. As such, a total amount of 342 connections provide the energy exchange between subsystems in the SEA model of the VLS fairing.

The overall pressure levels during the lift-off phase are estimated at about 160 dB. This noise has a (nearly) diffuse character. Since it is assumed that only elements with large surface areas are susceptible to this acoustic excitation, a diffuse pressure field excitation is applied to each of the plates in the SEA structural fairing model. The complete fairing model, with 176 structural elements, 1 acoustic 3-D volume, 64 diffuse pressure field excitations and 342 connections, is shown in Fig. 4. Observe the referred figure and note that all the subsystems described above are simulated in the model. Rectangular plates of the surfaces 1 and 3 ( $re_{i,j}$ ), triangular plates of the surfaces 2 and 4 ( $ti_{i,j}$ ), reinforcing beams of the surfaces 2, 3 and 4 ( $ri_{i,j}$  and  $ci_{i,j}$ ), excitation diffuse pressure field applied to the

panels ( $dpr_{i,j}$ ), as well the acoustic volume (vol) are present in this fairing vibro-acoustic SEA model.

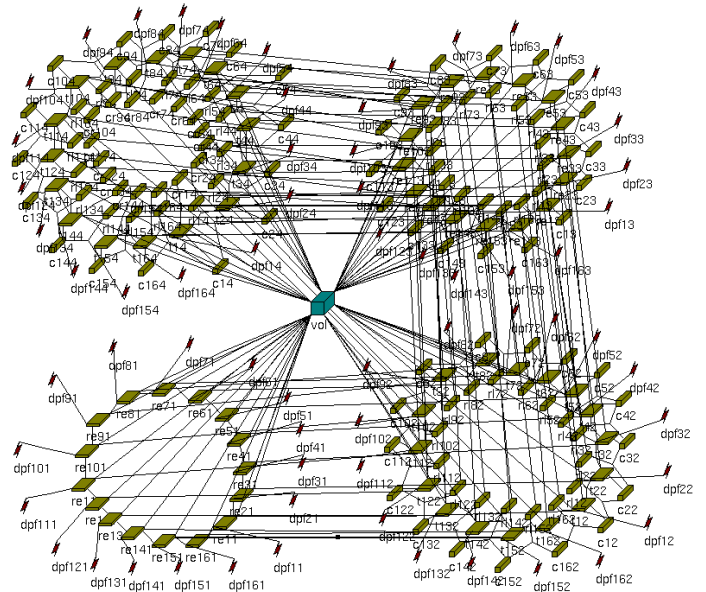

Figure 4: complete SEA fairing model

### 3. SEA response calculations

The energy levels and interactions of different subsystems are solved for the SEA fairing vibro-acoustic model described in section 2.2. Structural/acoustic investigations have, generally speaking, interest frequency range from 5 to 8,000 Hz. In this analysis, it is applied third octave bandwidth filters. As mentioned before, SEA technique is more effective in higher frequencies, where dynamic systems present higher modal density. As such, a criterious analysis must be done to determine the validity of the response calculations, using SEA.

Since the elasto-acoustic model is ready and when the primary entities in a SEA model are complete, the solution sequence can be started. LMS-SEADS performs the solution in the following steps:

- Modal Density calculations;
- Internal Loss Factor Calculations;
- Coupling Loss Factor Calculations;
- Global system Matrix Assembly;
- Input Power Calculation;
- Modal Power Calculation.

Bellow, some important SEA parameters are described and analysis of the main subsystems of the model is done, considering the main assumptions of the SEA theory, describe in section 2.1.

#### 3.1. Evaluating SEA Parameters

Subsystems modal density contained in all elements are calculated. In fact, the modal density parameter is the foremost important parameter for SEA, since this parameter can be used to calculate internal loss factor, coupling loss factor and assembly the global system matrix, as described in Eq. (9), which are the next steps of the solution procedure in LMS-SEADS. Modal density is a frequency dependent quantity related to a subsystem of an element and is defined as the asymptotic ratio limit of the number of natural frequency per unit frequency. It often varies monotonically with frequency, but in some cases, modes "clump" together to give local maximum. In rib-stiffened plates, the plate deforms uniformly in the lower frequency range. At a certain frequency, the bays between the ribs start to have local modes and as a result, the modal density increases suddenly. Structural and acoustic elements have their modal density plotted in Fig. 5.

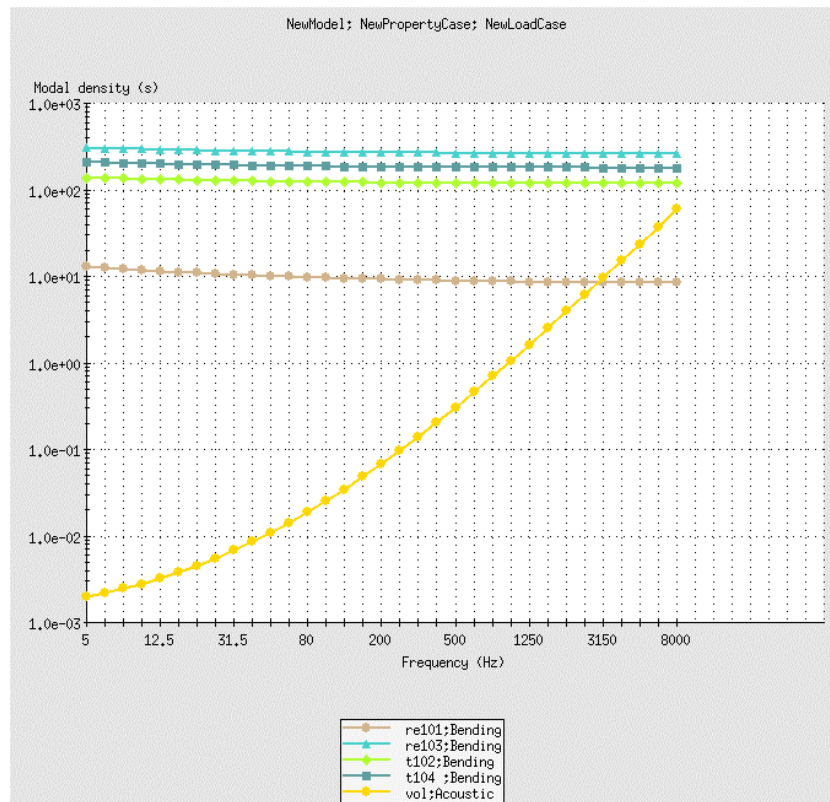

re101: rectangular plate 10, surface 1; re103: rectangular plate 10, surface 3  
t102: trapezoidal plate 10, surface 2; t104: trapezoidal plate 10, surface 4  
vol: acoustic volume

Figure N° 5: subsystem's modal density

As mentioned by Lyon and De Jong, 1995, and by De Langhe, 1998, the provided values in such analysis are not deterministic solutions of the problem. In SEA, one has statistical values that are not for a specific structure but are the mean for a particular ensemble. As such, calculated values for a specific subsystem is assumed to be the same for the others in the same surface of the fairing. For example, the obtained modal density of the rectangular plate 10 of the surface 1 (re101) is the same as the other rectangular plates of the same surface and can be assumed the mean modal density value of all the rectangular plates in surface 1. Such a way, it is enough to analyse only one element of each surface to obtain the desired mean SEA parameters.

The number of modes that lie in the frequency band is important in SEA either to help in identifying subsystems and in the analysis of errors. For frequency bands, the mode count is taken as the product of the bandwidth and the modal density. Figure 6 shows the plates mode count of the main subsystems of the model, as well as of the acoustic cavity, considering the bending waves. Longitudinal and torsion waves are not so relevant, since these subsystems present smaller number of modes.

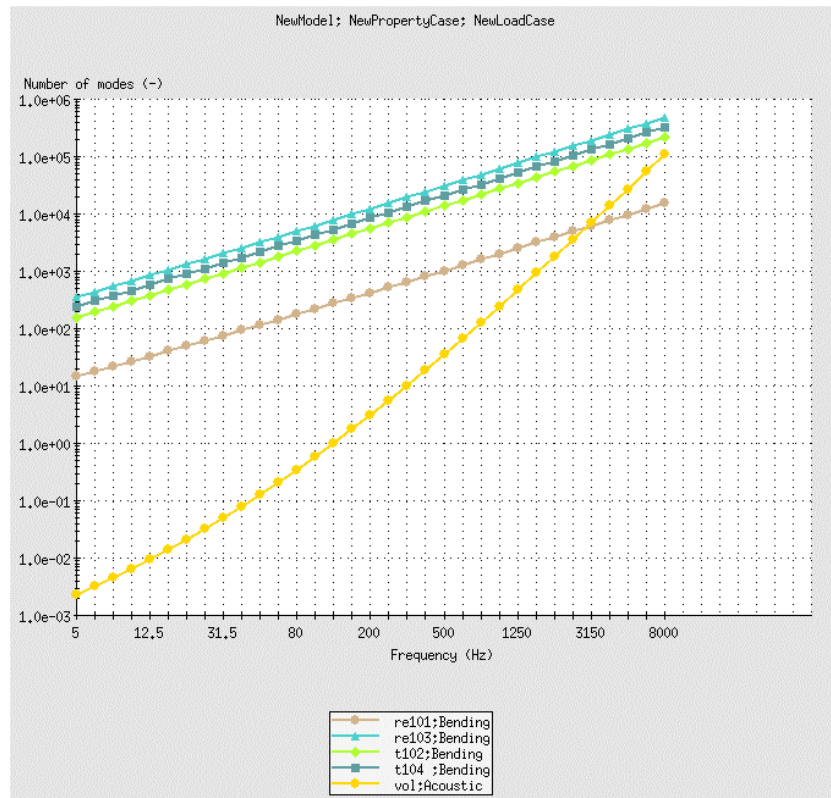

*re101: rectangular plate 10, surface 1; re103: rectangular plate 10, surface 3  
t102: trapezoidal plate 10, surface 2; t104: trapezoidal plate 10, surface 4  
vol: acoustic volume*

Figure N° 6: fairing plate's number of modes (bending)

As shown in Fig. 6, the mode count of the simple plates in surface 1 (brown) is smaller than the mode counts of the rib-stiffened plates of the surfaces 2, 3 and 4. This means that the rib-stiffened plate wave speeds are slower than the simple plate and errors in the rib-stiffened surfaces 2, 3 and 4 are smaller than errors in the simple surface 1.

It is important to mention that only the plate elements, which are more sensitive to acoustic excitation, are considered in this analysis. Such elements, with large surface area, are connected to the acoustic volume. Other elements as ribs and stiffeners, which represent ring frames and separation rails are not relevant for the vibro-acoustic analysis. The objective of this analysis is to predict the spatial average internal fairing acoustic response and an average vibration of the fairing skin. Local vibration responses of the rails and ring frames are not of interest, since these elements present low mode count and are not reliable in SEA analysis. Figure 7 shows the mode counts for different linear subsystems of the structural model of the fairing.

Verify Fig.7 and see that SEA analysis of ribs is not reliable, since error is entirely dependent on the mode count. As SEA models yield statistical parameters and precision increases with the modal density, one may consider that usual SEA models have gradual increase in the error with decreasing frequency. This is due to a variety of factors of which the decreasing number of modes is one. Some practical experiences show that the reliable frequency band for a subsystem analysis starts when the referred subsystem presents between three and five modes. Practical results have been showing that SEA analysis yield reliable vibro-acoustic predictions, starting from 5 modes in the bandwidth.



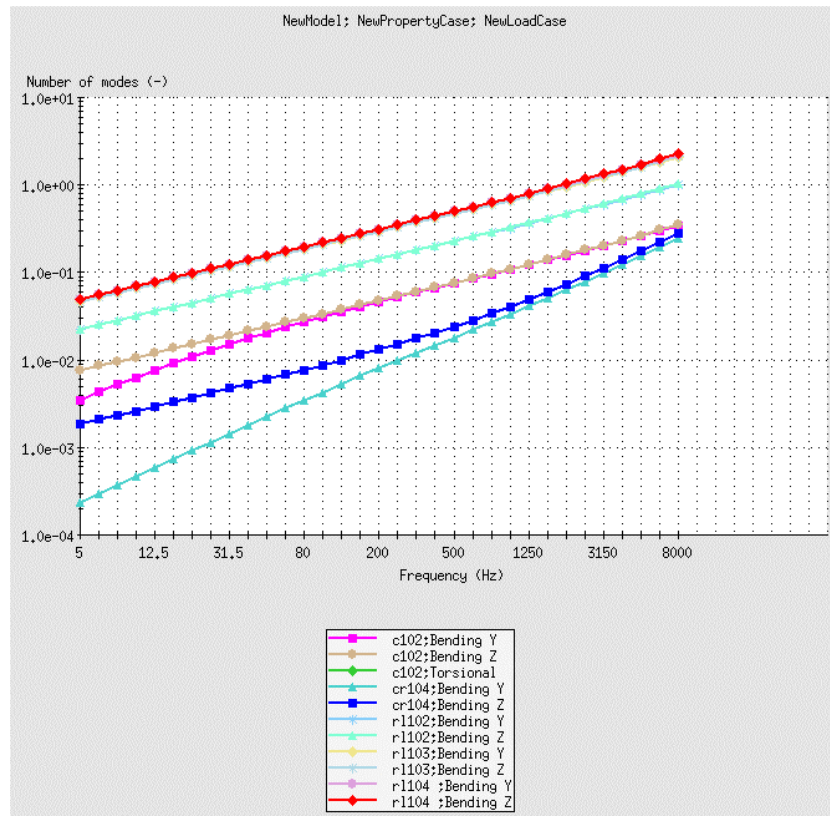

*c102: circular rib10, surface 2; cr104: circular rib10, surface 4  
 rl102: longitudinal rib10, surface 2; rl103: longitudinal rib 10, surface 3  
 rl104: longitudinal rib10, surface 4*

Figure 7: fairing ribs' number of modes (bending Y and Z directions)

A more useful parameter for determining an accurate analysis frequency bandwidth in SEA is the modal overlap factor, defined as the ratio of the modal bandwidth (either the half-power bandwidth or the effective bandwidth which is  $\pi/2$  times higher) to the average frequency spacing between modes. If the modal overlap factor is less than 1, then the part of the frequency spectrum is not damped controlled, which is assumed the case of SEA. If modal overlap factor is much bigger than 1, mode peaks are not apparent in the response functions. It can also be defined as the product of frequency, modal density and internal loss factor. In this framework, one can state that modal overlap is the fraction of the frequency spectrum that is controlled by resonant modes. Below, the structural plates bending and 3D acoustic cavity fairing modal overlap factors are shown (Fig. 8).

On one hand, verifying the coupled SEA case study of the VLS fairing, one can see that the structural modal overlap factors are resonant mode controlled for the whole analysis bandwidth. Once again, the comparison of the MOF of the rib-stiffened plates of the surface 2, 3 and 4 with the simple plates of the surface 1 (brown), shows that even though the simple plates are in the resonant mode controlled bandwidth, they present smaller MOF values than those of the rib-stiffened plates. This is due to the fact that the simple plates have higher thickness and consequently, higher order modes than the plates of the surfaces 2, 3 and 4. On the other hand, for the 3D acoustic volume, the bandwidth where modal overlap factor starts to be accurate for SEA analysis is around 300 Hz (resonant mode controlled bandwidth).

Another important SEA parameter is the modal power potential, which is equal to the average energy per mode (modal energy) times the frequency bandwidth of the average, in rad/sec, as shown in Fig. 9. For this parameter, an analogy with a thermal system can be made, where modal power is equivalent to the temperature. As such, this quantity is always larger at the point excitation and drops off in the direction of the power flow. Power always flows from a location with higher modal power to one with lower modal power.

The modal energy (or modal power potential) of the four surface structural subsystems as well as of the acoustic volume is plotted in Fig. 9.

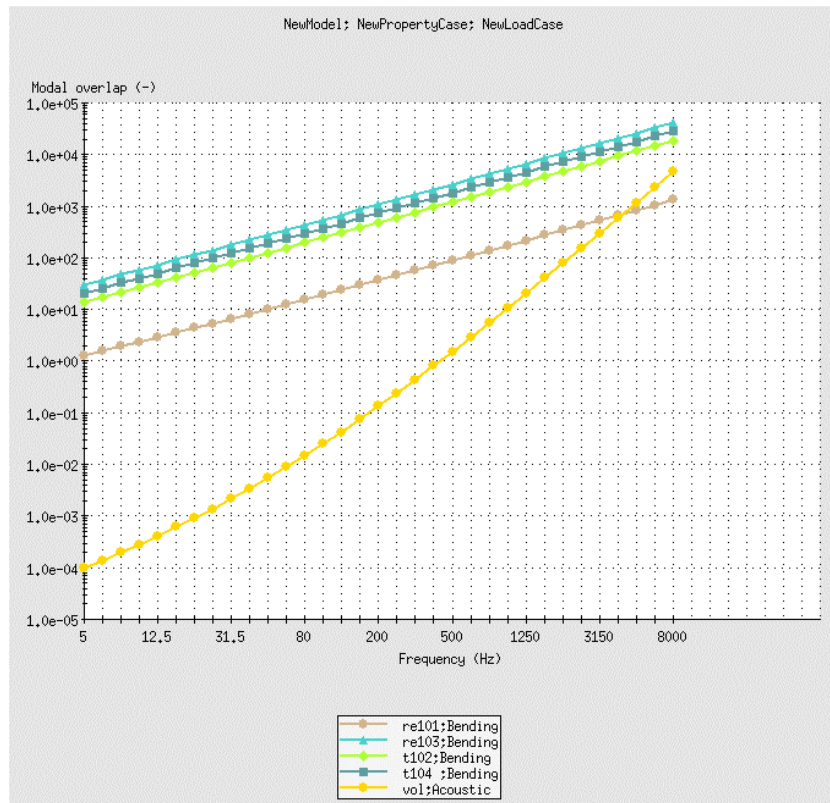

*re101*: rectangular plate 10, surface 1; *re103*: rectangular plate 10, surface 3  
*t102*: trapezoidal plate 10, surface 2; *t104*: trapezoidal plate 10, surface 4  
*vol*: acoustic volume

Figure N° 8: structural plate bending and 3D acoustic cavity fairing modal overlap factor (MOF)

Figure 9, shows that the structural surface 1 presents higher modal power, when compared with the modal powers of the structural subsystems (rib-stiffened plates) in surfaces 2, 3 and 4.

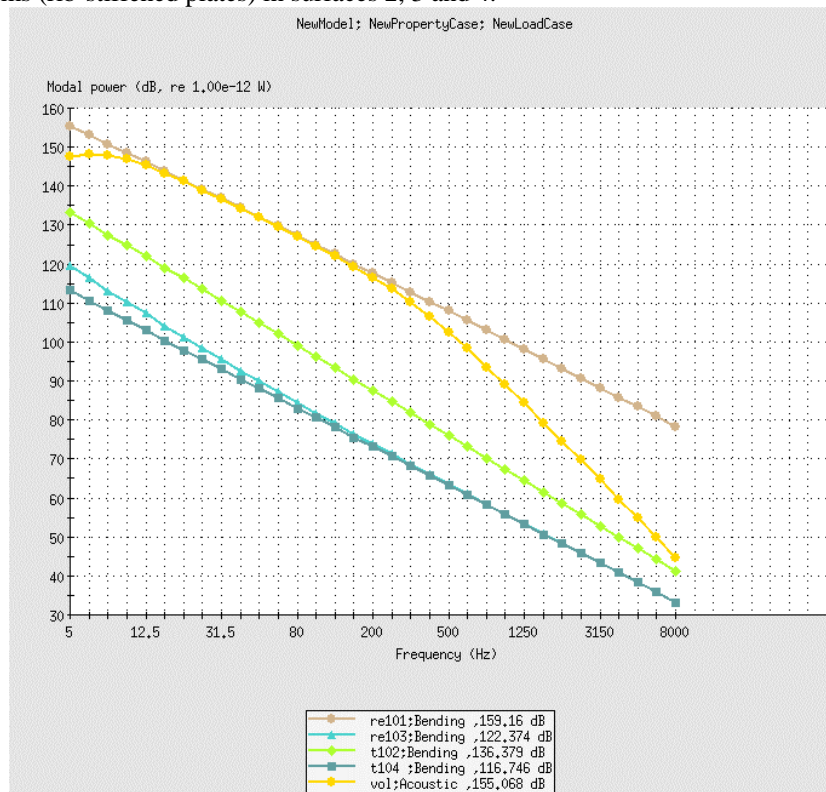

*re101*: rectangular plate 10, surface 1; *re103*: rectangular plate 10, surface 3  
*t102*: trapezoidal plate 10, surface 2; *t104*: trapezoidal plate 10, surface 4  
*vol*: acoustic volume

Figure N° 9: structural and acoustic volume modal power



This is due to the fact that the reinforced plates of the structural surfaces 2, 3 and 4 concentrate higher modal density than the simple plate of the surface 1 (see Fig. 5). Concerning the acoustic domain (yellow), it can be seen that the modal power decreases as the frequency increase. It was expected, since the analogy with the thermal system confirms this behavior.

After the analysis of the main SEA parameters, where the dynamic behaviour of all the subsystem of the vibro-acoustic model of the VLS fairing are described, it is important to calculate the acoustic behaviour of its inner cavity, when the fairing is submitted to the severe acoustic pressure level of 160 dB (OSPL), during lift off. As discussed during this work, this analysis was carried out considering the fluid-structure coupling, on which the fairing structural body, the internal acoustic cavity as well as the connection between these subsystems are taken into account. It is important to mention that acoustic pressure, velocity and others parameters, considered in the deterministic methods as primary variables, are secondary variables in SEA, since this statistical technique considers energy parameters as primary variables. Nevertheless, this is not a problem, since the software can easily calculate secondary variables (eq. (4)).

The frequency dependent output response of the acoustic subsystem represents the RMS pressure in the frequency band of analysis and is spatially and frequency averaged within the subsystem. Figure N° 10 presents the SEA prediction of the inner VLS fairing cavity. The pressure spectra (dB), calculated in third octave band, are shown for the frequency band from 5 to 8,000 Hz.

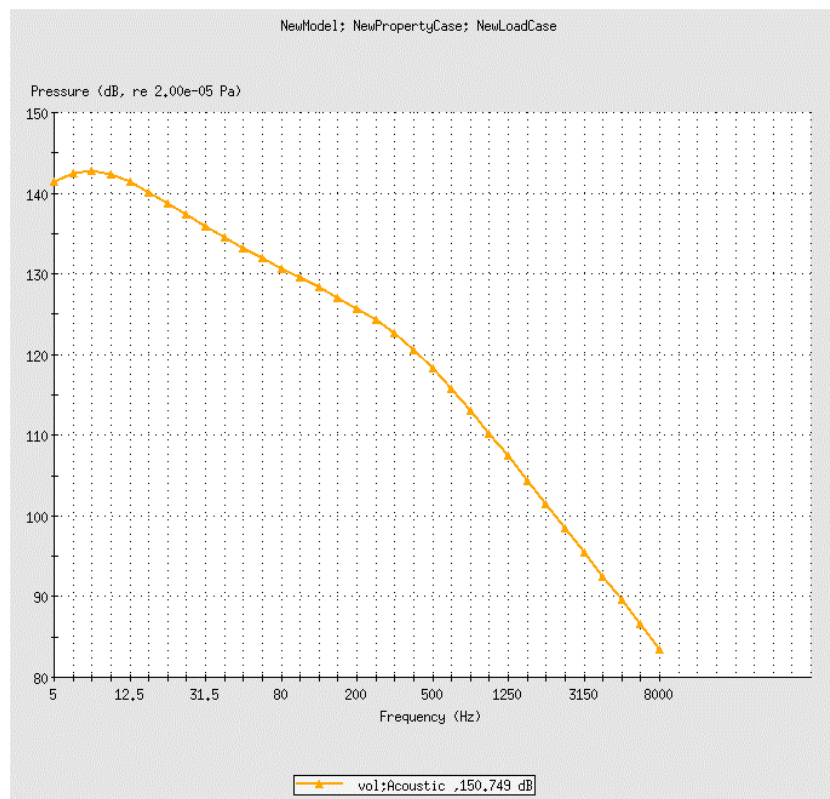

Figure 10: response spectrum of the inner fairing acoustic pressure

Observe the Fig. 10 and verify that LMS/SEADS calculated the inner space and frequency averaged pressure level for the whole frequency range, i.e., from 5 to 8,000 Hz. However, as it can be seen in Fig. 8, the valid SEA analysis frequency of the vibro-acoustic model of the VLS fairing starts around 300 Hz, since the modal overlap factor indicates that the frequency spectrum is controlled by resonant modes. Such a way, calculated responses bellow 300 Hz may not be considered as the pressure levels inside the fairing cavity. As shown in Fig. 10, the calculated pressure levels in the third octave central frequency of 20 Hz is about 140 dB. This acoustic pressure level is prohibitive inside the fairing, since the payload is not designed to withstand such a severe acoustic level (fortunately this calculation is not reliable). In the higher frequencies, for example in the third octave central frequency of 4,000 Hz, the calculated acoustic pressure level is approximately 94 dB.

#### 4. Conclusions

SEA has shown to be a very powerful alternative to be applied in high frequency predictions of vibro-acoustic systems, using coupled analysis technique. The limitations encountered using deterministic methods in high frequency analysis, is not verified applying SEA, which is an easy modelling technique. Concerning the computational effort and

allocated memory, SEA is very fast, since the number of subsystems (177 elements) is the degree of freedoms of the model. However, it is important to know that this technique yields averaged responses considering statistical parameters and the obtained responses are estimated parameters, considering an ensemble of a dynamic system, differently of the calculated results, using FEM/FEM or FEM/BEM techniques.

As it was discussed before, application of SEA is not reliable in low frequency analysis. In this bandwidth, deterministic analysis, as Finite Element Method (FEM) and/or Boundary Element Method (BEM), may be applied to complete the analysis frequency range, from 5 to 8,000 Hz. As such, a combination of deterministic and statistical analysis can yield the acoustic response of the fairing inner cavity, considering fluid-structural coupling.

The inherent errors using SEA technique are not yet well established, in the SEA theory. Such a way, care must be taken, mainly in medium frequency or twilight zone, where the limitations of the deterministic methods as big models and consequently prohibitive computational effort and memory allocation, are present and where the basic exigency of the SEA technique of high density modal is not yet satisfied.

## 5. Acknowledgements

The first author would like to thank the “Coordenação de Aperfeiçoamento de Pessoal de Nível Superior – CAPES”, as well as the Institute of Aeronautics and Space (CTA/IAE), for the financial and professional support to develop this work in Belgium.

Thanks to “Katholieke Universiteit Leuven”, in the person of Prof. Dr. Paul Sas, who was the supporter of this work, as well as to Prof. Dr. Wim Desmet.

## 6. References

- [1] Pirk, R., Vibro-acoustic Analysis of the Fairing of the Brazilian Satellite Launcher (VLS), Ph.D. Thesis, Instituto Tecnológico de Aeronáutica – ITA, 2003
- [2] Lyon and DeJong, Theory and Application of Statistical Energy Analysis, Second Edition, 1995
- [3] De Langhe, K., High Frequency Vibrations: Contributions to Experimental and Computational SEA Parameter Identification Techniques, Katholieke Universiteit Leuven, 1998
- [4] Kompella, M. S., Bernhard, R. J., Measurement of the Statistical Variation of Structural-Acoustic Characteristics of Automotive Vehicles, Proceedings of SAE Noise and Vibration Conference, Traverse City, Michigan, US, SAE paper 931272, (1993)
- [5] Zienkiewicz, O.C., The Finite Element Method - Vol. 1: Basic formulation and linear problems (McGraw-Hill, London, 1977)
- [6] Zienkiewicz, O.C., and Taylor, R.L., The Finite Element Method - Vol. 2: Solid and fluid mechanics, Dynamics and Non-linearity (McGraw-Hill, London, 1991)
- [7] Desmet, W, Vandepite, D., Boundary Elements in Acoustics, Katholieke Universiteit Leuven, 2000.
- [8] Defosse, H., Handi, M. A., Vibro-acoustic Study of Ariane V Launcher During Lift-off, INTERNOISE 2000
- [9] Troclet, B., “Analysis of vibro-acoustic response of launchers in the low and high frequency range”, *Proc. of NOVEM 2000* (Lyon, 2000)

## 7. Responsibility notice

The authors are the only responsible for the printed material included in this paper.