

MODELING OF AN ELEVATOR GROUP CONTROL SYSTEM USING PROGRAMMABLE LOGIC CONTROL AND DESTINATION CONTROL SYSTEM

Alvaro A. Patiño-Forero, patino@unb.br

Daniel M. Muñoz, damuz@unb.br

Guilherme Caribé de Carvalho, gccarval@unb.br

Carlos H. Llanos, llanos@unb.br

University of Brasilia, Department of Mechanical Engineering, Brasilia, D.F., 70910-900, Brazil

Abstract. Elevator group control systems (EGCS) have an important effect on the usefulness of buildings, especially for operation of large buildings. The most recent elevator systems have structural differences from the traditional ones, such as Destination Control Systems (DCS), Double-deck elevators, Multi-car elevator system as well as optimization algorithms and modern soft-computing methods. Performance of elevator systems that use DCS is improved given that control strategies can be implemented using the information of destination call before the passenger enters into a car. One of the main issues on controlling elevator groups is related to the measurement of traffic intensity in office buildings. Current studies show that passengers flow is often highest in a heavy incoming traffic situation, such as the traffic observed in the early hours of the morning, also known as the up-peak traffic. In order to deal with this demanding situation, the literature indicates the application of some recent developments, among which, the concepts of division zone technique together with the DCS concept were chosen to be used for the design of the EGCS model described in this paper. Information on call allocation allows special rules to be developed in order to assign an elevator to a sector. This paper proposes a new architecture for an elevator system in commercial office buildings by implementing a control strategy based on fuzzy logic using DCS for a single-car and based on a dynamic-sector approach. The architecture of the elevator group control system was designed to be implemented in a Programmable Logic Controller (PLC) using a DeviceNet® industrial network in order to interconnect industrial instrumentation. The DCS was modeled through human-machine interfaces (HMI) located at each floor.

Keywords: Elevators system, zoning division, destination control, PLC

1. INTRODUCTION

Elevator group control systems (EGCS) have an important effect on the usefulness of high-rise modern buildings. EGCS are control systems that systematically manage a group of elevators in order to efficiently transport passengers. The elevator system has a dynamic discrete event behavior, in which, the elevator assignment consist of a multi-objective problem that must be solved in real-time. The scheduling elevator problem is a *NP-hard* computational class and involves a stochastic process, considering uncertainty about the time instant at which a new hall-call button is pressed, about the number of passengers waiting in halls, among others (Beielstein *et al.*, 2003).

Commonly, the elevator system performance is measured using several criteria, such as, service quality related to the waiting time of passengers, traffic throughput and energy consumption (Beielstein *et al.*, 2003).

Conventional EGCS implementations are based on fuzzy logic, neural networks, genetic algorithms, Markov chains, among others (Kim *et al.*, 1998), (Liu and Liu 2007), (Ikeda *et al.*, 2008), (Nikovski and Brand, 2004). Previous works covering EGCS implementations for scheduling the elevators are focused on several aspects, such as, static zoning division and dynamic zoning division strategies. In the static zone approach the floors are divided in a number of zones equal to the number of elevators (Barney and Santos, 1985), (So *et al.*, 2001). In the dynamic zoning approach, each elevator has a service zone which changes according to the position and movement direction of the elevators, in order to balance the elevators state between busy and idle (Yang *et al.*, 2007).

In a traditional elevator control system, up and down hall-call buttons are used. The latest elevator system has structural differences from conventional systems, such as Destination Control Systems (DCS), which allow to know the desired floor before the user enter in a car (Markon *et al.*, 2008). Performance of elevator systems that use DCS is improved given that control strategies can be implemented by using the previous information about the number of passengers waiting for a car, as well as, the passengers desired destinations. Such a control systems result in a more accurate destination assignment to the elevator cars, once the control system can group the passengers going to the same floor in the same car, reducing the waiting time and the number of stops (Sorsa *et al.*, 2005).

Based on the experience reported by several authors in the literature, this paper proposes a Fuzzy Elevator Group Control System (FEGCS) that identifies traffic patterns and selects the most suitable elevator for attending a hall-call. We focus on the control strategy applied for commercial office buildings using an approach based on dynamic zone division according to the current traffic condition in the building. The FEGCS receives as one of the input parameters the information sent with one destination Data Input Hardware (DIH). Also, this paper describes a new architecture for an elevator system, using a PC for implementing the FEGCS, a Programmable Logic Controller (PLCs) for performing

the Local Control Systems (LCSs) and industrial instrumentation, such as a *DeviceNet*® industrial network and human-machine interfaces, such as *PanelView*®, for implementing the input and output interface between the passengers and the FEGCS, it is called DIH. This architecture allows the elevator system to benefit from the advantage proportioned by industrial automation, highest safety and integration with the other systems in modern office buildings.

Section 2 describes briefly the conventional elevator systems and its main components. Section 3 presents the related works covering fuzzy logic and zoning division approaches for solving the scheduling elevator problem and before concluding, Section 4 describes the proposed architecture and the control algorithms.

2. ELEVATOR SYSTEM

The Elevator Group Control System (EGCS) manages systematically three or more elevators in a group to increase the service of passengers, reducing the waiting time and the power consumption. Most of the EGCS's have used the hall call assignment method which assigns elevators in response to passenger's calls. In this case, the EGCS considers the current traffic situation of a building to select the most appropriate elevator (Kim *et al.*, 1995).

Figure 1 shows a conventional elevator system using Destination Control System (DCS), with one destination Data Input Hardware (DIH) per floor. Several Local Control Systems (LCS), one per elevator, can be observed in this architecture. Each LCS receives as inputs the commands sent by the EGCS and control the traction engine of the respective elevator, as well as the other common tasks such as checking the presence of obstacles before closing the doors, monitoring the car weight, controlling the opening and closing the doors, etc. The LCS's are connected to the EGCS through a communication network, as well as, the DIH are connected to the EGCS in order to send the following commands: (1) current floor from which a new hall-call is issued. (2) Destination floor of the new hall-call. The use of DIH's allows the controller to know previous information before the users enter into a car.

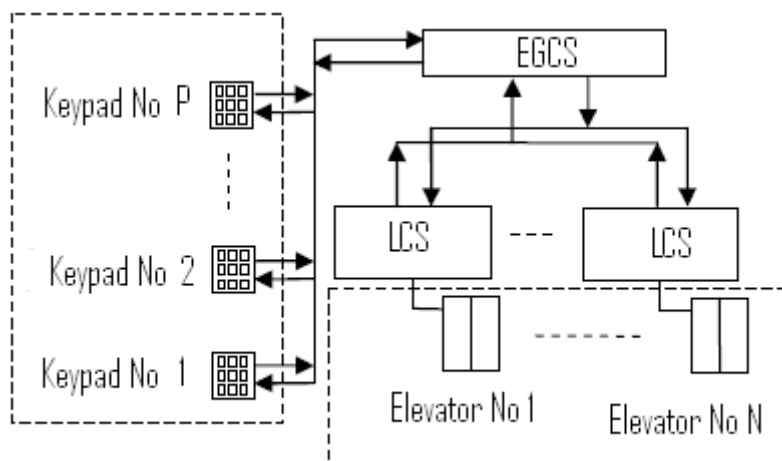

Figure 1. Elevator system (Tai *et al.*, 2008)

One of the ways of implementing the LCS's is by using a Programmable Logic Controller (PLC). A PLC is an industrial computer used for automation purposes. PLC's are used in many industrial process and machines, such as packaging, manufacturing processes, semiconductor machines, among others. The PLC's are designed for multiple inputs and output arrangements, extended temperature ranges, immunity to electrical noise, and resistance to vibration and impact. A PLC is an example of a real time system since output results must be produced in response to input conditions within a bounded time. The PLC's includes different communication protocols that may be used such as *DeviceNet*® or *Profibus* (Erickson *et al.*, 1996), (Schiffer *et al.*, 2000).

3. RELATED WORKS

Many studies have been proposed in order to implement different control strategies for Elevator Group Control System (EGCS), improving the performance in different traffic situations. However, due to the non-linear and the stochastic behavior of the scheduling elevator problem, an analytic solution is difficult to be found; therefore, the most common strategies are based on probabilistic approaches such as Markov chains (Nikovski and Brand, 2004) and artificial intelligent techniques such as fuzzy logic (Kim *et al.*, 1998), neural networks (Liu and Liu, 2007) and genetic algorithms (Ikeda *et al.*, 2008).

A method for generating the elevator control strategy, based on fuzzy logic, was proposed by Kim *et al.* (1998). The authors entitled such a method as Fuzzy Elevator Group Control System (FEGCS) and it was based on the classification of traffic status along the day, using fuzzy rules, and on a dispatcher manager for assigning the hall-calls

to suitable elevators. Such a strategy resulted in a dynamic behavior for the controller in such a way as to adapt its performance to the changing elevator demands found during a working day. The control strategy tries to deal with three criteria, namely: (a) reducing the passenger average waiting time; (b) reducing the power consumption; and (c) reducing the rate of long waiting calls. A similar approach was adopted by Siikonen (1997), who proposed a FEGCS based on a forecasting method and a fuzzy system for traffic patterns recognition. Also, in this FEGCS, the next floor to be visited by the car is calculated using a cost function, taking into account the current traffic situation in the building.

Control approaches using different kind of zoning division was proposed by Barney and Santos (1985), who adopted specific algorithms for static and dynamic sectoring. Static sectoring uses a control algorithm to detect when the up traffic from the terminal floor exceeds a pre-determined level. This situation could be present when the number of passengers waiting for a car threatens to overload the lift system capacity. The algorithm will assign each car to serve a particular building zone. Dynamic sectoring uses the same protocol as static, but includes a feedback algorithm, which allows the sectoring to vary from trip to trip according to the traffic demand (Russett *et al.*, 2003).

Recently, new models of elevator group intelligent system with Destination Control System (DCS) have been proposed by Yang *et al.* (2009). They studied a dynamic partition method in the up-peak traffic situation. This method dynamically adjusts the floor zone division based on flow rate and distribution of passengers. A dynamic programming algorithm is used to solve the floor zone division problem and a Fuzzy Neural Network is developed in order to implement the optimal scheduling policy.

In general, approaches using DCS allow to increase the handling capacity in up-peak traffic situations. In previous works, the waiting time of passengers has been decreased, obtaining better performance than approaches using heuristic control rules (Tai *et al.*, 2008).

Nowadays, the elevator system is expected to allow the implementation of complex algorithms for performing the dispatcher of the elevator cars in an efficient way, further to being sufficiently robust, reliable and secure in terms of hardware and software. Therefore, the elevator control system implementation using the well proven Programmable Logic Controller (PLC) technologies could be an important advance in the development of reliable and easily maintainable elevator systems.

Yang *et al.* (2008) describe an architecture involving only one low end PLC for implementing an elevator system with two elevator cars and nine floors; however, they do not consider the use of elevator group control strategy, thus limiting the scalability of the elevator system. Also, the authors (Yang *et al.*, op. cit.) did not consider the use of DCS in their implementation. Therefore, it is expected that the performance of such an elevator control system is worse than that expected from a more elaborated one, mainly in heavy traffic situations. Architectures using PLC's and DCS's have been currently implemented by the ThyssenKrupp company (ThyssenKrupp, 1999), who proposes an architecture based on PLC's and a CAN bus network ensuring reliable connection of all components. Such architecture considers the use of one PLC for implementing the Local Control System (LCS) of each elevator. However, considering that the algorithms involved in the LCS's do not need complex computations, a simpler and cheaper solution, in terms of hardware needed, would be the implementation of as many as possible LCS's in the same PLC.

4. DESCRIPTION OF THE PROPOSED ARCHITECTURE

The architecture of the proposed elevator system is shown in Fig. 2. This architecture consists of an elevator group controller running on a microcomputer (e.g. an industrial version of a personal computer), a Programmable Logic Controller (PLC) for implementing the Local Control Systems (LCS's) and a *DeviceNet*® industrial network for connecting several instrumentations such as AC Drives, sensors and HMI's (Human Machine Interfaces), the later for implementing the destination Data Input Hardware's (DIH's).

The elevator group controller was designed using the division zoning technique and a Fuzzy Elevator Group Control System (FEGCS) for computing the suitable priority of each elevator in order to attend a hall-call. The priority value is computed taking into account standard criteria of performance, such as, passenger average waiting time, load capacity of the elevator cars and distance (in number of floors) between the hall-call and the destination call. The elevator group controller also implements a fuzzy system for identifying traffic patterns in office buildings.

The elevator group controller was developed in Java language and receives the decisions from the FEGCS in order to select the elevator with the highest priority value for attending a new hall-call and performs the zoning division taking into account the current traffic situation in the building.

As shown in Fig. 2, the proposed architecture considers only a PLC for implementing several LCS's, taking advantage of the versatility and robustness of such industrial device. The LCS implements basic algorithms for controlling several local tasks, such as: (a) driving the car electrical lift motor; (b) controlling the door actuator for opening or closing operations; (c) checking the status of the car and shaft sensors; etc. A *DeviceNet*® industrial network is proposed for connecting the PLC with the field devices, such as the AC Drives (one for each elevator car), the inductive sensors in the shaft and the HMI's (*PanelView*®, one per floor), though which hall-call data are input to the DCS's.

The communication between the PLC and the group controller was accomplished by a client-server Java application called OLE for Process Control (OPC) (OPC Foundation, 1996). The OPC allows a standard for real-time information exchange between software applications and hardware processes.

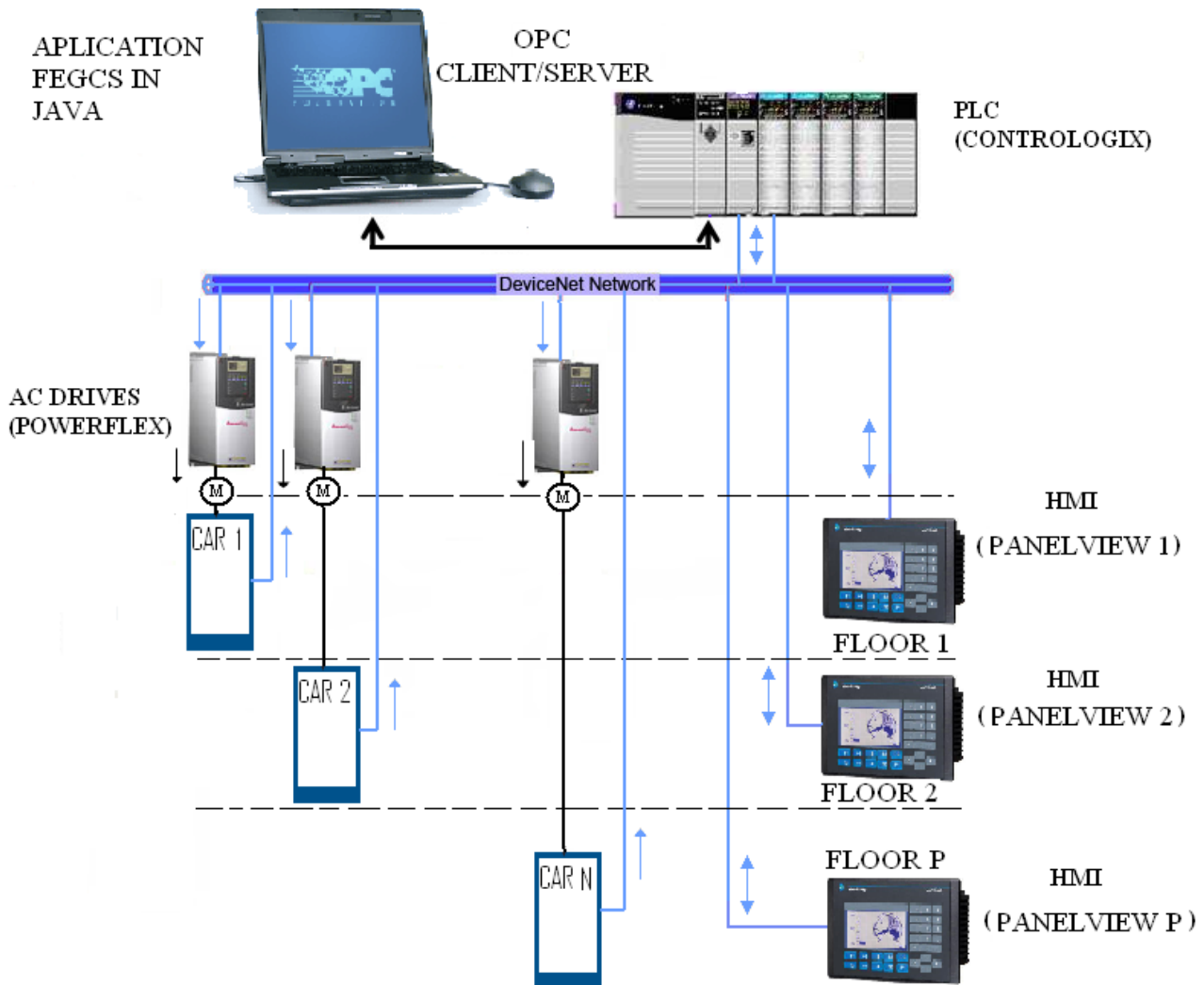

Figure 2. Architecture of the elevator system

4.1 The zone division technique

In this work, the zone division technique is used for adapting the elevator group controller to the traffic conditions in the building. Therefore, this technique takes into account the traffic patterns identified by the FEGCS. These traffic patterns have different characteristics which vary along the day. Table 1 describes the characteristics of traffic patterns used in this work and the proposed zone division for each identified pattern. In this work, the sector division system proposed by Barney *et al.* (2003) was used. According to this approach, the number of division zones correspond to the number of elevators in the building and each elevator is allocated to only one zone, attending the corresponding hall-calls in a collective way (Nikovsky and Brand, 2003).

Table 1. Traffic patterns and zone division

Traffic Patterns	Description	Zoning Division
UP (Up Peak)	A high number of incoming passengers is expected in early working hours of the building and after lunch return.	The first floor (lobby) is assigned to a zone. The remaining floors are divided in symmetric zones (same number of floors).
BT (Business Time)	More interfloor calls are expected. Total traffic is medium and small.	Symmetric zones. When an elevator remains inactive for more than 5 seconds, its status is

		declared as free and it is lead to the boundary between adjacent zones, being available in the up or down direction.
DP (Down Peak)	A high number of outgoing passengers is expected at the end of the day and also immediately before lunch time.	Symmetric zones.
HT (Heavy Traffic)	Many passengers gather into a floor. Up, down and interfloor calls. Total traffic is high.	In this case an algorithm was implemented for dividing the zones according to centralized floors. The floor with more than 50% of centralized traffic is assigned to a zone and the remaining floors are divided in symmetric zones.

4.2 The traffic identifier

Figure 3 shows the structure of the traffic system identification. This system is based on fuzzy logic and was developed using the Xfuzzy tool (Xfuzzy 3.0, 2003). This system receives as input four traffic characteristics and returns the current traffic pattern in the building, choosing one among four traffic patterns (see Tab. 1). The traffic identifier is periodically executed (commonly every 15 minutes) (Siikonen, 1997). Table 2 describes the four traffic characteristics used in this work. The number of up and down hall-calls and the number of passengers waiting in the halls can be computed by using the information provided by the destination Data Input Hardware's (DIH's) (see Fig. 2).

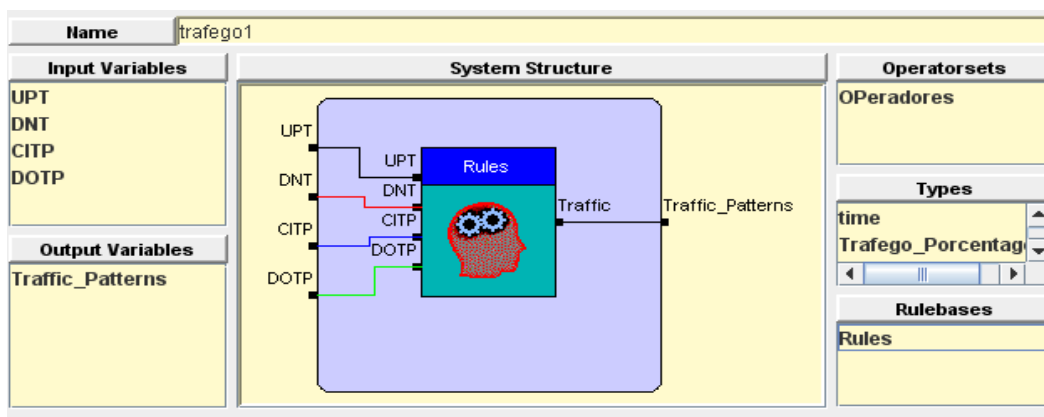

Figure 3. Fuzzy traffic identifier

Table 2. Input variables for zoning division

UPT (UP Traffic)	Number of up going passengers
DNT (Down Traffic)	Number of down going passengers
CITP (Centralized Incoming Traffic Percentage)	Ratio of the incoming passengers in the most crowded floor to the total of incoming passengers of all floors.
DOTP (Distributed Outgoing Traffic Percentage)	Ratio of the out-going passengers in all floors except the most crowded floor to that of all floors.

4.3 The elevator priority calculation

When a new hall-call is requested, a fuzzy system is executed in order to compute the priority value of each elevator for attending this hall-call. This computation must be performed N times in order to find the most suitable elevator, where N is the number of elevators. Figure 4 shows the structure of the fuzzy system that computes the priority value of one elevator.

The fuzzy system receives as input three important variables of the performance measurement of elevator systems, as follow:

- a) Distance: is the number of floors that the elevator must travel from its current position to the floor where the new hall-call occurred.
- b) Loading car: The loading car is the current number of vacancies available in the car when it arrives at the floor from where the hall-call occurred.

- c) Waiting time: is the estimated time that the passengers must wait in the halls until the elevator arrives at the floor after the passenger input his desired destination to the system via the DIH. The estimated waiting time is computed using equation (1).

$$\text{Waiting Time} = (\text{Number of stops}) \times T_v + (\text{Distance}) \times T_s \quad (1)$$

Where, *Number of stops* stands for the number of stops the elevator car is scheduled to between its current position and the hall-call position; T_v stands for the sum of the door opening time and the door closing time; and T_s , for the travel time between two adjacent floors at the rated speed.

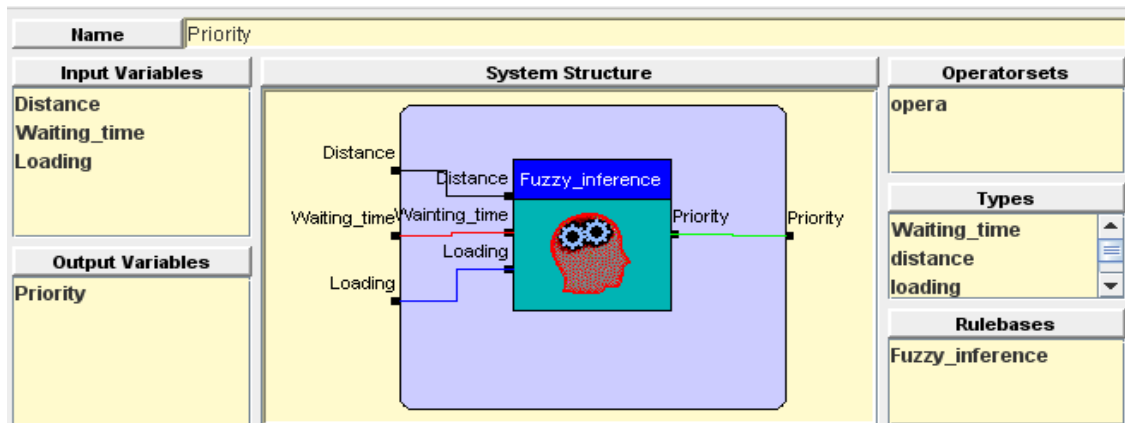

Figure 4. Fuzzy priority calculation

4.4 The main algorithm

This algorithm controls the elevator system by using a zone division approach and a Fuzzy Elevator Group Control System (FEGCS) for computing the priority value of the elevators and the traffic patterns identification. The zone division approach considers that the number of division zones corresponds to the number of elevators in the building, and then, each elevator is allocated to only one zone, attending the corresponding hall-calls. When an elevator is currently assigned to a zone, this zone is called *occupied zone*. In the other hand, when a zone has not an elevator assigned, it is called *empty zone*.

Figure 5 describes the flowchart of the main algorithm which is run when a new hall-call is requested. This algorithm consists of five stages. At the first stage the algorithm has a current zoning division, which is setup by the fuzzy traffic identifier. This is run every 15 minutes (see section 4.2) in order to follow the traffic change along the day. According to the literature (Siikonen, 1997), such an actualization interval is sufficient to detect variations in the traffic, which is expected to vary in a low frequency pattern, unless an event of fire alarm occurs. In such a case, the elevator control system might be programmed to follow the local regulations regarding its behavior in the case of fire. The traffic identification frequency does not cause any problem to the FEGCS, since it only provides a reference for the zone selection. Therefore, it does not directly affect the LCS. However, the traffic actualization interval may be adjusted to suit particular situations. At the second stage the algorithm carries out several decision operations in order to determine if this zone is considered as an empty zone. These decision operations require the information about the occupation of the zone from which the new hall-call was requested, about the direction of the elevator with respect the hall-call direction and about the loading capacity of the elevator (in case of an elevator to be currently assigned to this zone).

When the zone is empty the algorithm executes the third stage, otherwise executes the fourth stage. The third stage executes the fuzzy priority calculation (see Fig. 4) in order to select the most suitable elevator for attending the hall-call requested. Finally, at the fourth stage, the state of the zone where the elevator car is currently situated is considered occupied and, then, the algorithm dispatches the elevator by using the collective principle (Nikovskiy and Brand, 2003) until the elevator leaves the zone, after which it is declared an empty zone.

4.5 The communication protocol

The communication between the FEGCS and the PLC is a client-server application and was accomplished in Java language. This communication is carried out through OPC (OLE for Process Control) which is an open communication protocol widely used in industrial automation and enterprise systems. The OPC protocol runs in a microcomputer and was implemented in the same algorithm as the elevator group controller, as shown in Fig. 5.

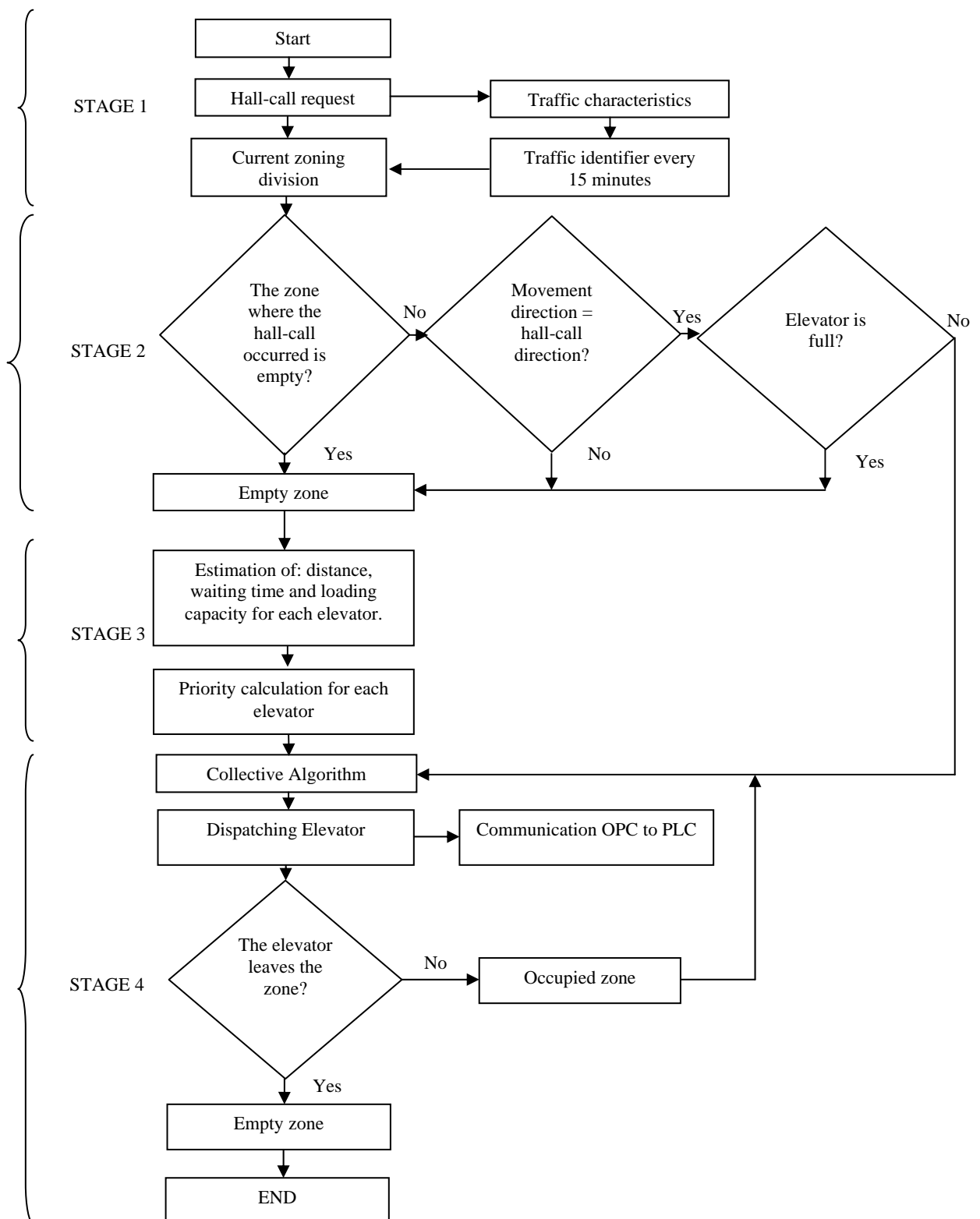

Figure 5. Flowchart of the main algorithm

The OPC-server allows the group controller to interchange data with the PLC. This data are based on state variables and action commands. The state variables indicate the current state of each elevator and the action commands indicate the decision from the main algorithm that must be executed by the elevators in order to improve the performance of the overall system.

5. CONCLUSIONS

This paper proposes a new architecture for elevator systems based on a *DeviceNet*® industrial network for connecting several industrial devices, such as: the Programmable Logic Controller (PLC), which implements the Local Control Systems (LCS's); the *PanelView*®'s, which implement the human-machine interfaces, the AC Drives and shaft sensors. An OLE for Process Control (OPC) was developed in Java language sending data between the PLC and an Elevator Group Control System based on fuzzy logic (FEGCS) and division zone techniques.

The FEGCS was designed to increase the performance of the elevator system, taking advantages of the division zone techniques and the traffic patterns identification, as well as, the previous information provided by the destination Data Input Hardware (DIH), thus avoiding the uncertainties of the conventional system. The LCS was designed to be implemented in only one PLC, saving industrial instrumentation, decreasing energy consumption and implementation cost. By accomplishing the proposed architecture we hope that the elevator system takes advantage of the security, versatility and robustness provided by industrial instrumentation. However, such architecture might present a flaw in the sense that each elevator instrumentation is connected to the PLC via its own industrial network. In the event of a cable problem, the corresponding elevator might be unusable until it is fixed. This could be minimized by adopting a redundant architecture for the network, for example using two network scanners in each elevator shaft and a ring network architecture, thus providing an alternative path to the data in the case of a cable discontinuity.

Several assumptions must be considered according to the building structure (number of floors and number of elevators) in order to implement the LCS's on the PLC. Obviously, the PLC dimensioning will depend on the size of the building as well as on the number of elevators contained within the group. The PLC can be connected to several *DeviceNet*® scanners, depending on the size of its memory. Each *DeviceNet*® network scanner allows connecting up to 64 nodes and has a limited memory size. Therefore, depending on the number of floors, and consequently the number of HMI's needed, it might be necessary to configure more than one *DeviceNet*® network in order to make it possible to install all of them. This drawback might in one hand increase the cost of the system, but on the other hand brings increased scalability and robustness on the data transmission.

The use of OPC protocol provides high versatility and flexibility in the transmission of the information, allowing the industrial systems to explore new approaches for controlling automation integrated systems in modern buildings.

As future works we intend to study the scalability of the proposed architecture in order to explore the capabilities of the PLC of implementing complex elevator control systems.

6. ACKNOWLEDGEMENTS

The authors would like to acknowledge the material and financial support provided by Rockwell Automation do Brasil Ltda, without whose support this work would not have been possible.

7. REFERENCES

- Barney G. C. and Dos Santos S. M., 1985 "Elevators traffic analysis: design and control. UK :IEE" , Peter Peregrinius Ltda.
- Barney G.C, 2003 "Elevator Traffic Handbook: Theory And Practice", Spon Press, London and New York.
- Beielstein Thomas, Markon Sandor, Mike Preuss, MIC2003 "A Parallel Approach to Elevator Optimization Based on Soft Computing" in The Fifth Metaheuristics International Conference.
- Erickson Kelvin, 1996 "Programmable Logical Controller", Potentials, IEEE.
- Ikeda Kokolo, Suzuki Hiromichi, Kita Hajime, Markon Sandor, 2008 "Exampler-based Control of multi-car Elevators and its Multiple-objective Optimization using genetic algorithm", conference system computers and communication.
- Kim, C.B., Seong, K.A., Lee-Kwang, H., Kim, J.O. 1998. "Design and Implementation of a Fuzzy Elevator Group Control System." In: IEEE Transactions on Systems Man and Cybernetics Part A 28(3), pp. 277-287.
- Kim Bum Chang, Seong Kyoung A., Lee-Kwang, Kim O. Jeong and Lim Bae Yong, 1995 "A Fuzzy Approach to Elevator Group System", IEEE Transactions on Systems, Man, and Cybernetic, Vol 25, No 6.
- Liu Jianchang, Liu Yinyang, 2007 "Ant Colony Algorithm and Fuzzy Neural Networkbased Intelligent Dispatching Algorithm of an Elevator Group Control System", IEEE International conference on control and Automation.
- Markon Sandor, Aoki ichi Ken, Masami Nakagawa, and Takeshi Sudo, 2008 "Recent Trends Group Control System", Conference System computers and communication.
- Nikovski Daniel, Brand Matthew, 2004 "Exact Calculation of ExpectedWaiting Times for Group Elevator Control", mitsubishi electric research laboratories.
- Nikovsky, Daniel, Brand, Matthew, 2003. "Decision-Theoretic Group Elevator Scheduling." In: AAAI Proc. 13th Int. Conference on Automated Planning and Scheduling, pp. 133-142, Trento, Italy.
- OPC Foundation, 1996 "Dedicated to interoperability in automation", 21 August 2009 < <http://www.opcfoundation.org> >
- Russett Simon, 2003, "Lift Group traffic Control", Building Services Journal January, PP 45-46.

- Schiffer Viktor, Kerry W. Vandesteeg, David A. Vasko, 2000, "Introduction to DeviceNet Safety", Rockwell Automation, IEEE.
- Siikonen Marja-Liisa, 1997 "Elevator Group Control with Artificial Intelligence", KONE Corporation.
- Sorsa J., Hakonen and M. L. Siikonen, 2005 "Elevators selection with Destination Control System". In Elevators Technology.
- So A. T. P. and J.K.L. Yu, 2001 "Intelligent supervisory control for lift: Dynamic zoning", Building Serv. Eng Res. Technol, vol 22, no.1 pp 14-33.
- Tai Jianzhe, Yang Suying and Tan Hong, 2008, "Dispatching Approach Optimization of Elevator Group Control System with Destination Floor Guidance using Fuzzy Neural Network*", World Congress on Intelligent Control and Automation.
- Thyssenkrupp Modernization elevators optional, 1999 "Modernização ThyssenKrupp Elevadores", 22 May 2009, <<http://thyssen.ag2.com.br/manager/download.asp?onde=conteudo&arquivo=Opcionais.pdf>>.
- Yang Xiaoling, Zhu Qunxiong, Xu Hong, 2008 "Design and Practice of an Elevator Control System Based on PLC", Workshop on Power Electronics and Intelligent Transportation System.
- Yang Suying, Tai Jianzhe and Shao Cheng, 2009 "Dynamic Partition of Elevator Group Control System with Destination Floor Guidance in Uppeak Traffic", journal of computers, vol. 4, no. 1.
- Yang Zhenshan, Cheng Shao and Li Guizhi, 2007 "Multiple-Objective Optimization for EGCS Using Improved PSO Algorithm", American Control Conference.
- Xfuzzy 3.0 2003, CAD tool for fuzzy logic.22 May 2009 <http://www.imse.cnm.es/Xfuzzy/Xfuzzy_3.0/download.htm>

8. RESPONSIBILITY NOTICE

The authors are the only responsible for the printed material included in this paper.