

Fuzzy Logic Applications in Control of Robotic Manipulators

Tiago Ferreira de Freitas

Robotic and Automation Laboratory – COPPE/UFRJ
Federal University of Rio de Janeiro - UFRJ
Postal Box 68.503 – CEP 21.945-970 – Rio de Janeiro, RJ, Brazil.
e-mail: freitas@labrob.coppe.ufrj.br

Max Suell Dutra

Robotic and Automation Laboratory – COPPE/UFRJ
Federal University of Rio de Janeiro - UFRJ
Postal Box 68.503 – CEP 21.945-970 – Rio de Janeiro, RJ, Brazil.
e-mail: maxdutra@ufrj.br

Abstract. Fuzzy Logic (nebulous logic) is a one of the fields from computation what else has been growing on the last years, principally due the advance from the new computational technologies. These applications may be found at diverse devices of the day - the - day , such as into the control of machines of wash, juncture, air-conditioning and another. In robotics, can you to apply with certain satisfaction, control with logic nebulous (Fuzzy Logic Control) with the design of simplify and improve the performance of the control of manipulators. The control system of robotic manipulators is complicated, overall when the screening it is of type real time. Sum the that, the fortifications no linearity (centripetal accelerations and of Coriollis, geometry, friction and rests), coupling dynamic among the components from the mechanisms, influences abrupt (shifts on the trajectories thanks to obstacles, shifts into the loading of the manipulative and another), and another factors of errors (parametric uncertainty, errors of template and another) that if they meet in a manipulator. Other big problem associate with the control in real time is the weather spend about to if prosacute some dice of control, such as those obtained for inverse kinematics, what has a high consumption computational due on the complexity from the equations, the one to can occur in delay into the control. This paper presents the technique of "partitionement" fuzzy for modeled of inverse dynamics by one robotic manipulator of 4 degrees of freedom, as of experimental data. The system of inference fuzzy, in this case, it works like a box black, where can determine the torques of exit of each joins, from the displacements of the joins, without know the template analytic, barely by using if of experimental data.

Keywords. : Fuzzy Logic, robotic manipulator, inverse dynamics.

1 – Introduction

Fuzzy logic is based on decisions taken starting from imprecise parameters (nebulous). In many situations, it cannot define a state of the system in a quantitative way, being necessary to use linguistic variables, what generates a certain imprecision in the description of its state. An example would be the definition of the thermal comfort in a room based on linguistic variables. In other words, the room could be "hot", "moderately hot", "normal", "moderately cold" or "cold". The classification of the thermal comfort, in this case, would be of qualitative nature, what would generate a certain imprecision degree with relationship to the thermal comfort, because the sensation of hot or cold, it can vary of person for person, and depending case, of place for place. In areas whose temperature is frequently high, a temperature of 30°C could be considered normal, differently for an area whose temperatures are usually low, and the normal temperature oscillates around 20°C. Therefore, the concept of "cold" or "hot", it depends on a series of factors that are not necessarily related of direct form.

Starting from this focus, it is noticed that the evaluation of the precision of a manipulator's positioning in the space could be related with linguistic variables, which could guarantee a good positioning of the manipulator, in spite of all its non lineally (rests, attritions and dynamics).

Many works have been made with fuzzy logic as control form in robotic manipulators. The fuzzy control in redundant systems (dynamics or kinematics) (Lee et al, 1997), position control in underactuated systems (Muscato, 1999) and control dynamic (Emami et al., 2000) are examples of applications.

Mainly in complex control, where the conventional techniques don't accomplish the control requirements satisfactorily. This is due to the fact that the conventional control laws are of nature crisp, in other words, they present very defined control algorithms that generate actions of quantitative control. In some task levels, such algorithms don't possess an appropriate acting, because many factors are of qualitative and nebulous nature, be in the manipulator, or in its task or atmosphere, and that cannot be expressed in quantitative terms in a necessary way.

It can be mentioned as example, the difference between the human grasping of an rubber ball and a glass lamp. Translating this difference of behavior for an algorithm of a robot's control, in a perfected way, has several difficulties that can involve a series of rules that they are not always expressed in the form of a precise algorithm.

These rules represent the knowledge associated to a private task and it will usually be of qualitative and imprecise nature, which could be improved through experience and learning. In this work the methodology of Emami et al. (2000) will be presented to model the inverse dynamics of a robotic manipulator with the application of the foundations of fuzzy logic.

2 - Basic notions for a Control Model with Fuzzy Logic

An example, of controller with fuzzy logic, it is represented according to the diagram of blocks of the Figure 1:

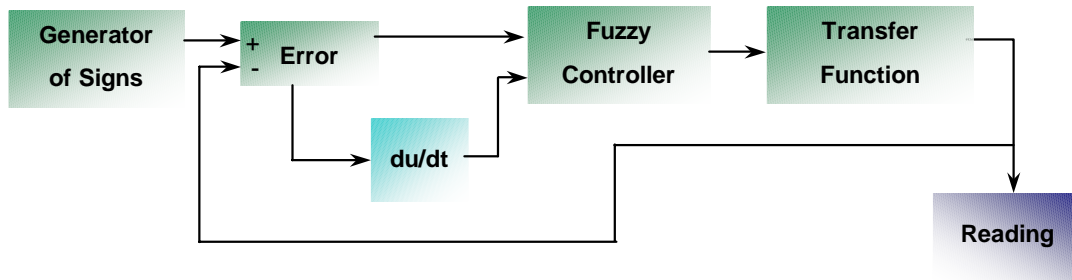

Figure 1. Block Diagrams of a Fuzzy Controller.

The system above represents a controller fuzzy whose inputs are the error and the variation of the error. Therefore, the fuzzy controller possesses inference rules that look for to minimize the error. The rules are of the type "if - then ", as: "If error it is big positive and variation of the error is growing, then torque it is high positive".

Where the error, variation of the error and torque are controller functions of pertinences, where the last corresponds the exit of the same. In fuzzy structures, the intensity of the error, for instance (big negative, appropriate, big positive), it is associated to a certain degree pertinence, different from the *crisps* structures, where an element is present or not. In other words, it is supposed that the function characteristic f_A associates all the elements that belong to the group inside A of a speech universe x . Then, it has:

$$f_A = \begin{cases} 1; & x \in A \\ 0; & x \notin A \end{cases} \quad (1)$$

In fuzzy structures, the characteristic function f_A can assume an infinite number of different values in the interval $[0,1]$. Like this, a fuzzy group is a group of orderly pairs:

$$A = \{\mu_A(x) / x\} \quad x \in X \quad (2)$$

where $\mu_A(x)$ it is the function of pertinence of x in A and it is defined by the listing of X in the closed interval $[0,1]$:

$$\mu_A(x) : X \rightarrow [0,1] \quad (3)$$

The pertinence function indicates how much an element belongs to a given set. Therefore, it can be known how much a variable belongs to a given set.

Therefore, the error definition as high negative is an imprecise amount, nebula. So it's possible to associate the error with a pertinence function whose linguistic variables could be: high negative, appropriate, high positive. The graph below (Figure. 2) represents an example of a possible pertinence function for the error:

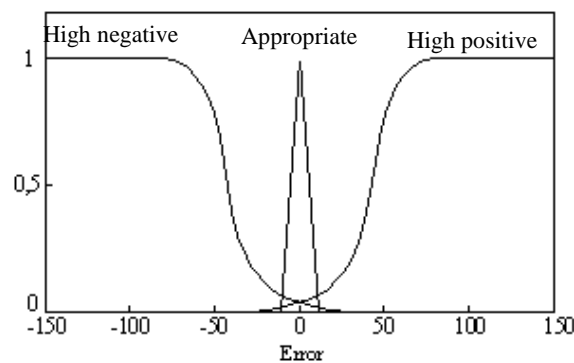

Figure 2. Function of Pertinence for the error input.

The error of the robotic manipulator could be associated with the positioning error of its end-effector, or even in the movement of rotation of your joints. A decision that looks to bring the error to an adaptation range, what it is the objective of the fuzzy control. For that, it is necessary that the control system can transform a quantitative information in a nebulous structure (fuzzyfication), to map them in function of another nebulous structure (inference machine), and finally, to transform the nebulous structure in a quantitative variable (defuzzyfication) with the purpose of settling down the control.

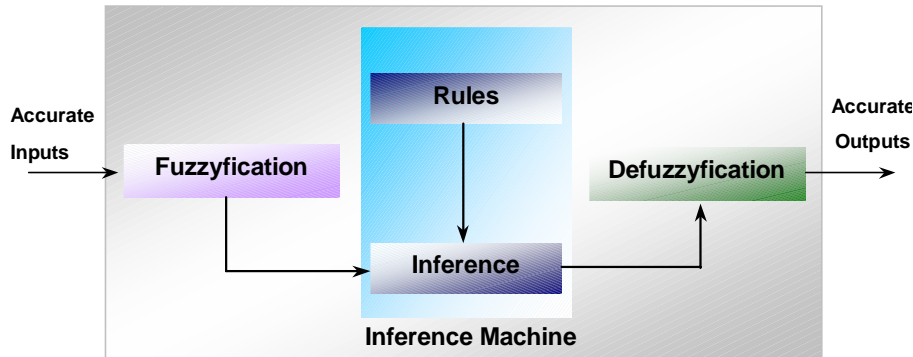

Figure 3 - System of Fuzzy Inference

The inputs are accurate, because they are usually obtained through measurements (error) or observations. In the fuzzyfication, the inputs are turned into variables fuzzy (linguistic variables), with the purpose of activating the rules, so that the inference can be accomplished. The inference nothing else is of what to map the variables input fuzzy in variables exit fuzzy. It is finally, the defuzzyfication consists of converting the variables exit fuzzy in accurate values.

The rules used in the inference machine they can be obtained by specialists or for simulations (Tanscheit, 2001). In the section to proceed, the method is presented for formulation of the pertinence rules for a system of control of inverse dynamics of a robotic manipulator of 4 degrees of freedom, as presented in the work of Emami et al. (2000).

3 - Modelling of the Fuzzy Controller

The proposed methodology considers the inference mechanism as an identifiable object of a fuzzy system (Figure. 4).

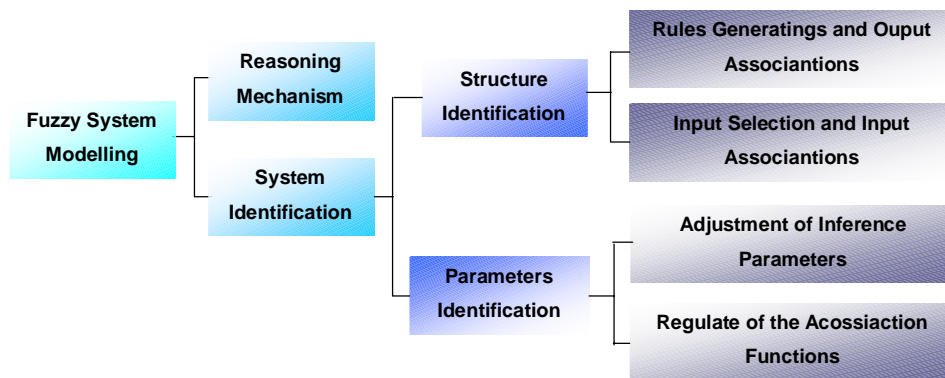

Figure 4 - Fuzzy Modelling Process

Therefore, the first step to model a fuzzy system is to determine the reasoning mechanism. In this work the identification mechanism will be adopted, where some the manipulator's data are acquired by simulation (displacement, acceleration, speed, torque in the joints), and starting from these data is possible to identify the system and to generate the pertinence functions, and to adjust them according to own system parameters.

3.1 – Identification of the Fuzzy Structure

The identification of the structure has as purpose to point out the number of rules, the most significant variables of input, functions of input pertinence and outputs necessary for the model fuzzy.

3.1.1 - generation of Rules and Functions of Pertinence

An intuitive approach for generation of objective rules is based on the partitionment of the input and output data. Here a methodology will be presented where initially, the output data are partitioned, and then the partitions of fuzzy input are derived through the orthogonal projection of each output partition in relation to input partition, separately. One of the advantages of this methodology is its simplicity and applicability, mainly in systems with a great number of input variables. The idea of the fuzzy partitionement is to divide the output data in fuzzy partitions that overlap each other. Therefore, the content of each data y_k for each partition i with center v_i it is defined by the degree of pertinence μ_{ik} in an interval $[0,1]$. The pertinence degrees and the centers of the partitions are obtained through a iterative procedure:

$$\mu_{ik,t} = \left[\frac{c}{\sum_{j=1}^c \left(\frac{\sqrt{y_k - v_{i,t-1}}}{\sqrt{y_k - v_{j,t-1}}} \right)^{2/(m-1)}} \right]^{-1} \quad (4)$$

$$v_{i,t} = \frac{\sum_{k=1}^N (\mu_{ik,t})^m y_k}{\sum_{k=1}^N (\mu_{ik,t})^m} \quad (5)$$

where N is the number of data, $\mu_{ik,t}$ is the degree of pertinence of the output y_k in the partition i , c is the number of partitions, and $v_{i,t}$ is the center of the partition i , in the t -ésima iteration. Three factors are essential for the construction of a satisfactory partition starting from the obtained data:

- appropriate number of rules to express the behavior of the system, where in most of the cases it is same to the number of partitions;
- the order of the fuzzyfication of the model of the system represents the underposition of the partitions fuzzy, and it is adjusted by the parameter m , denominated exponent of fuzzification weight;
- satisfactory initial location of the centers of the partitions that affect the formation of the model.

1. Specification of the Number of Rules

The proposed index is developed with the purpose of pointing out the best number output rules of the partitions in the fuzzy model, in density function and of the separation among partitions:

$$s_{cs} = \sum_{k=1}^N \sum_{i=1}^c (\mu_{ik})^m ((y_k - v_i)^2 - (v_i - \bar{v})^2) \quad (6)$$

where, \bar{v} is a medium weight of the data, considering the associations of the partitions, which it is defined as:

$$\bar{v} = \frac{1}{\sum_{i=1}^c \sum_{k=1}^N (\mu_{ik})^m} \sum_{k=1}^N \sum_{i=1}^c (\mu_{ik})^m y_k \quad (7)$$

Minimization of s_{cs} will increase the density of the partitions and the separation among them, simultaneously. Therefore, the optimal number of partitions will correspond to the minimum of s_{cs} . In most of the cases, c (number of partitions) it is same to the number of rules of the fuzzy model.

2. Specification of the Fuzzyfication Order

The fuzzyfication exponent weight m controls the magnitude of the sharent pertinence among the fuzzy partitions outputs in function of the group of obtained data. It varies in the range of $[0,+\infty]$, and as larger the value of m , more strong is the association for each datum. Obtaining m , the following index was developed:

$$S_T = \sum_{k=1}^N \left(\sum_{i=1}^c (\mu_{ik})^m \right) (y_k - \bar{v})^2 \quad (8)$$

An appropriate value of m is that whose trace of S_T is same to a constant $1/2K$, where K is defined as:

$$K = \sum_{k=1}^N \left[\left(y_k - \frac{1}{N} \sum_{j=1}^N y_j \right)^2 \right] \quad (9)$$

3. Centers of the Initial Partitions

The centers of the initial partitions are obtained through advanced and complex techniques of computation (Emami et al., 1998), that won't be approached in this work.

3.1.2 - Selection of Inputs and the Functions of Input Pertinence

With the objective of identifying the more significant input values among the input variables candidates, firstly it should project if the output partitions orthogonally to the space of each candidate input partition. Therefore, for each candidate input x_j has a pertinence function B_{ij} ($i=1,2,\dots,n$). Therefore, the following index is had:

$$\pi_j = \prod_{i=1}^n \frac{\Gamma_{ij}}{\Gamma_j}, \quad j = 1,2,\dots,\hat{r} \quad (10)$$

where Γ_{ij} is the range in the which the pertinence function B_i is equal to one, Γ_j is the total range of x_j , n is the number of rules, and \hat{r} is the number of input candidates. As smaller π_j , more dominant it is the variable x_j , and for consequence, more significant it is the variable. Therefore, the most relevant variables are thoses that they produce smaller π_j values.

The pertinence functions B_{ij} for the significant inputs are formed starting from Γ_j and for the use of the "partitionement fuzzy in line" described by Emami et al. (1998).

3.2 - Identification of the Fuzzy Parameters

The pertinence functions that convert an crisp (x^*) input for an fuzzy output, they are obtained in the following way:

$$E(y) = \beta\{1 - S_p(T_p[\tau_1(x^*), \bar{D}_1(y)], \dots, T_p[\tau_n(x^*), \bar{D}_n(y)])\} + (1 - \beta)S_p\{T_p[\tau_1(x^*), D_1(y)], \dots, T_p[\tau_n(x^*), D_n(y)]\} \quad (11)$$

where τ_i is called as degree of the rule, and it is computed for:

$$\tau_i(x^*) = T_q[B_{i1}(x_1^*), B_{i2}(x_2^*), \dots, B_{ir}(x_r^*)] \quad (12)$$

It is worth to point out that D_i is the fuzzy output, where:

$$\bar{D}_i(y) = 1 - D_i(y) \quad (13)$$

The equations of the n -th operator t -conorma (S_p) it is given by:

$$S_p(a_1, a_2, \dots, a_n) = [a_1^p + (1 - a_1^p)[a_2^p + (1 - a_2^p)[\dots[a_{n-2}^p + (1 - a_{n-2}^p)[a_{n-2}^p + (1 - a_{n-1}^p)a_n^p] \dots]]]^{1/p}, \quad p > 0 \quad (14)$$

The operator T_x ($x = p, q$) it is the n -th operator t -norm, that is calculated as:

$$T_x(a_1, a_2, \dots, a_n) = 1 - S_x[(1 - a_1), (1 - a_2), \dots, (1 - a_n)] \quad (15)$$

The Equation (11) it is a lineal combination of two extreme reasoning approaches, Mamdami and Logic, with adjustable parameters. The crisp output is obtained by the method of the defuzzyfication basic distributed, that is given for:

$$y^* = \int_{y_0}^{y_1} \frac{y[E(y)]^\alpha dy}{\int_{y_0}^{y_1} [E(y)]^\alpha dy}, \quad 0 \leq \alpha \leq \infty \quad (16)$$

By this reasoning formulation, i.e., Equations (11) and (16), four parameters (p , q , α and β) are introduced, whose variation can generate a range continuous of variation of the mechanism of reasoning of the fuzzy system.

Therefore, the otimização of this mechanism depends on the appropriate adjustment of these parameters, that are function of the input and output data.

The adjustment of these parameters gives itself through a otimization problem of restriction non linear, through the minimization of:

$$PI(p, q, \alpha, \beta) = \sum_{k=1}^N (y_k - \hat{y}_{k-1})^2 / N \quad (17)$$

where the restrictions are:

$$0 < p, q < \infty, \quad 0 < \alpha < \infty \quad 0 < \beta < 1$$

where y_k is the k -th current output and \hat{y}_k is the k -th output of the model.

The functions of input-output pertinence that were already identified in the phase of identification of the structure are approximate for functions trapezoids, and then a procedure of incremental refinement is applied to adjust the parameters of the pertinence functions based on the data adjustment and in the Equation (17).

4 - Dynamic modelling Fuzzy-Logic to the Robotic Manipulador

The system model of the fuzzy structure -logic is presented at Figure 5:

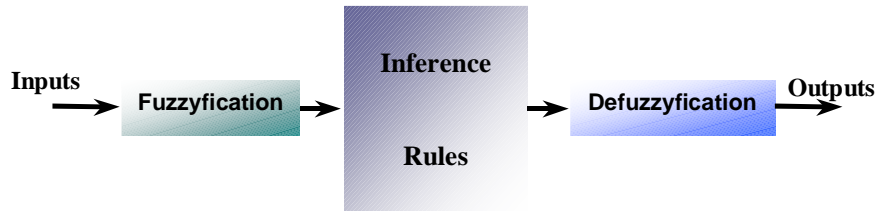

Figure 5 - Structures of the System Control Fuzzy-Logic's for Inverse Dynamics.

Such system is also called model of inverse dynamics, which generates the forces and the torque requested as functions of a given path of the system. In this section all the steps will be discussed for fuzzy modelling, from the acquisition of data to the model validation, with the purpose of illustrating the complete methodology for modelling of a fuzzy-logic controller.

In general, the model of inverse dynamics to robotic manipulator with S degrees of freedom, it can be represented for:

$$\tau_s = F_s(q, \dot{q}, \ddot{q}, \xi), \quad s = 1, 2, \dots, S \quad (18)$$

where q, \dot{q}, \ddot{q} are vectors of the displacement, speed and acceleration of the joints, respectively, and τ_s is the applied torque at the s -th joint and ξ is the vector of the manipulator's cinematic and dynamic parameters. The function F_s is highly no-linear due to the friction, rests and other effects. It is worth to point out that the equations are dynamically coupled. Starting from the point of view of the fuzzy logic, the knowledge of the system can be defined for S models of fuzzy logic, where each model expresses the torque of a joint as function of the movement of all the joints. In other words, each model consists of rules of the type " If - Then " with many antecedent variables, that is, displacement, speed and acceleration of the joints, and a consequent variable that would be the torque of the joint. Therefore, a model fuzzy-logic for the joints s ($s = 1, 2, \dots, S$) with n rules, it could be expressed as:

$$\begin{aligned} \text{IF } x_{s1} \text{ is } B_{s1l} \text{ AND } \dots \text{ AND } x_{sr} \text{ is } B_{s1r} \text{ THEN } \tau_s \text{ is } D_{s1} \\ \text{IF } x_{s1} \text{ is } B_{snl} \text{ AND } \dots \text{ AND } x_{sr} \text{ is } B_{snr} \text{ THEN } \tau_s \text{ is } D_{sn} \end{aligned} \quad (19)$$

Where $x_{s1}, x_{s2}, \dots, x_{sn}$ are the variables of significant inputs for the joint s , identified among the elements of the vectors q, \dot{q}, \ddot{q} ; and τ_s is the torque of output of the joint s ; $B_{sij} \in D_{si}$ ($i = 1, \dots, n; j = 1, \dots, r$) are the fuzzy structures representing the pertinence functions of the input and of the output respectively. For each joint, the applied torque could be influenced by the dynamics of all the joints, and consequently $3S$ candidates of input can be considered. However, the number of significant inputs is usually smaller, depending on the type and of the configuration of the manipulator's joints.

5 - Data Acquisition for Modeling Fuzzy-Logic

The robotics manipulator analyzed it is the IRIS Robot, of the Laboratory of Automation and Robotics of the University of Toronto (Emami et al., 2000). It has four degrees of freedom, and its joints are perpendicular to each other, as demonstrated in the Figure (6).

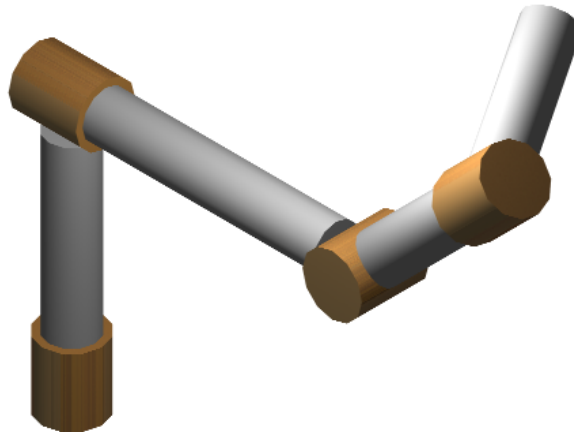

Figure 6 - Illustrative of the Manipulator Iris Robot.

The acquisition of data is made from sensor of displacements of joints, as encoders and load cells for measurement of the torque in the joints. Starting from this, a path is defined to be followed by the manipulator in the space, and the data of the displacements are stored and of the torque of the joints accomplished to execute such path. The speeds and accelerations of the joints can be obtained starting from the derivation on-line of the displacements.

In the Figure (7) the graphs of displacement of the joints are presented for two paths randomics accomplished by the manipulator.

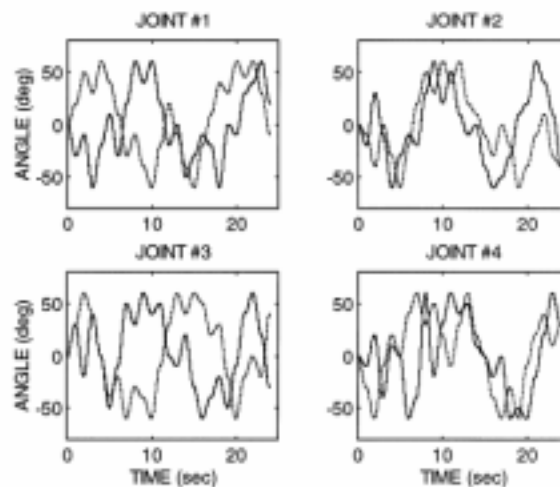

Figure 7 - Displacement of the Joints for Two Randomic Paths (Emami et al., 2000).

To proceed, in the Figure (8) measured medium torque is presented in the joint 4.

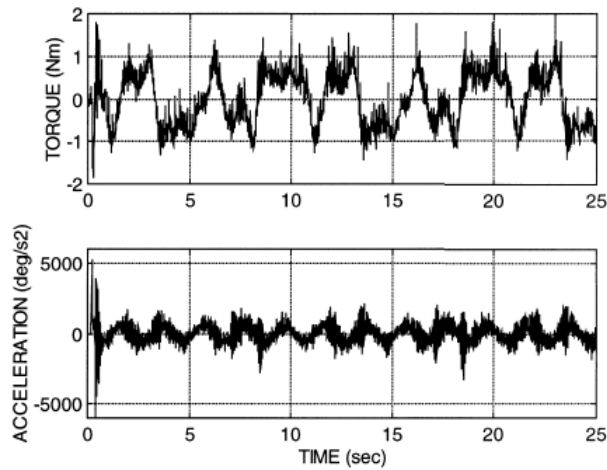

Figure 8 - Torque and Acceleration of the Joint 4 (Emami et al., 2000).

6 - Identification of the System

After the data are acquired, the process of identification of the system begins. The first step is partition the output data, i.e., the torque of the joints. For this, initially it is specified an optimal value of fuzzyfication degree and of partitions (m and c , respectively). In the Figure (9) the graph of the line of S_t is traced in function of m . the appropriate magnitude of m is obtained according to the strategy proposed in the sub-section *Generation of Rules and Functions of Pertinence*. The index s_{cs} (Eq. (6)) for the selection of the optimal number of partitions, based on the selection of m , it is also shown in the Figure (9).

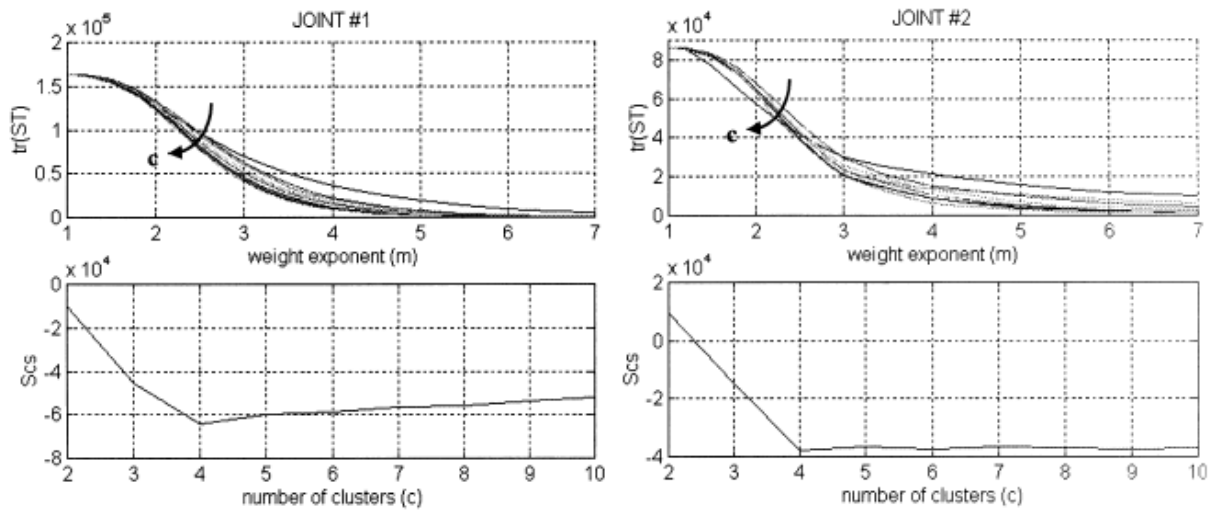

Figure 9(a) - Validation of the indexes m and c for the joints of the Iris manipulator (Emami et al., 2000) – Joints 1 and 2.

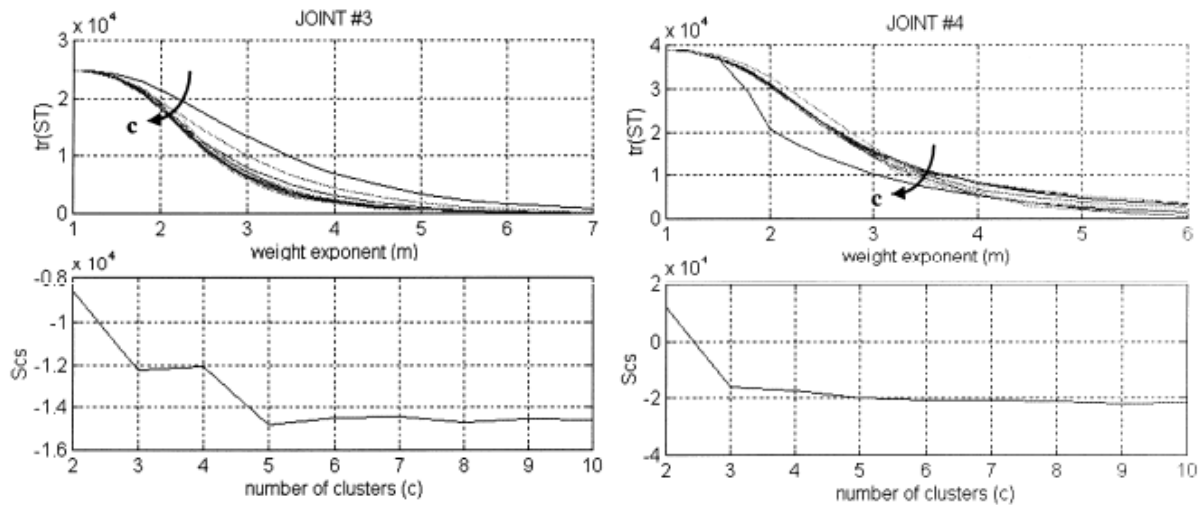

Figure 9(b) - Validation of the indexes m and c for the joints of the Iris manipulator (Emami et al., 2000) – Joints 3 and 4.

In the Table 1 are listed the values of m and c . Starting from these values, she can partitione and to classify the output data, and to derive the pertinence functions and its consequent rules.

Table 1 - Fuzzyfication Exponentes and Partition Numbers.

Joint	Fuzzyfication Exponent (m)	Partition Number (c)
Joint 01	2,8	4
Joint 02	2,5	4
Joint 03	2,2	5
Joint 04	2,5	6

The next step is to identify the most significant variables of each joint, which it can be done according to the strategy proposed by the minimization of the value of π (Eq. (10)).

The values of π for the joint 1 are presented below:

$$\begin{array}{lll}
 \pi_{q_1} = 0,5113 & \pi_{q_2} = 0,9290 & \pi_{q_3} = 0,8742 \\
 \pi_{q_4} = 0,9689 & \pi_{\dot{q}_1} = 0,0354 & \pi_{\dot{q}_2} = 0,6660 \\
 \pi_{\ddot{q}_3} = 0,6883 & \pi_{\ddot{q}_4} = 0,5908 & \pi_{\ddot{q}_1} = 0,0079 \\
 \pi_{\ddot{q}_2} = 0,0647 & \pi_{\ddot{q}_3} = 0,0711 & \pi_{\ddot{q}_4} = 0,0400
 \end{array}$$

Obviously, the variables $\dot{q}_1, \ddot{q}_1, \ddot{q}_2, \ddot{q}_3, \ddot{q}_4$ are the dominants among 12 candidates. This selection is consistent second a physical judgement of the dynamic system. For all the joints, the accelerations and the speeds corresponding of each joint are specified as the most important input variables. The significant variables, together with the parameters of refinement of each joint, they are presented in the Table 2.

Table 2 - Variables of Input Selected and Parameters of Refinement (p, q, the, b) of each joint

Joint	Input Variables	P	q	α	β
Joint 1	$\dot{q}_1, \ddot{q}_1, \ddot{q}_2, \ddot{q}_3, \ddot{q}_4$	0,484	1,043	3,38	0,218
Joint 2	$\dot{q}_2, \ddot{q}_1, \ddot{q}_2, \ddot{q}_3, \ddot{q}_4$	0,955	20,00	1,68	0,153
Joint 3	$q_1, q_3, \dot{q}_3, \ddot{q}_1, \ddot{q}_2, \ddot{q}_3, \ddot{q}_4$	0,530	1,59	4,97	1,00
Joint 4	$\dot{q}_4, \ddot{q}_2, \ddot{q}_4$	2,98	9,99	3,63	0,046

Starting from the values described in the Tables 1 and 2, more the data obtained experimentally, it becomes possible to generate the pertinence functions.

One of the outstanding characteristics of the control modelling by Fuzzy Logic is in the simplicity in describing the behavior of a system, just as a black box, and its performance is satisfactory if compared with the

analytic model. The great difficulty of analyzing the system analytically is in certain parameters of difficult modelling, such as the friction and the rest, that are of stochastic nature.

The pertinence functions are given below at (Fig. (10) ~ Fig. (13)). In the superior part of the illustrations are presented the input values for each variable of the fuzzy system, and in the last column the output defuzzified of the torque. Each line corresponds the inference rule.

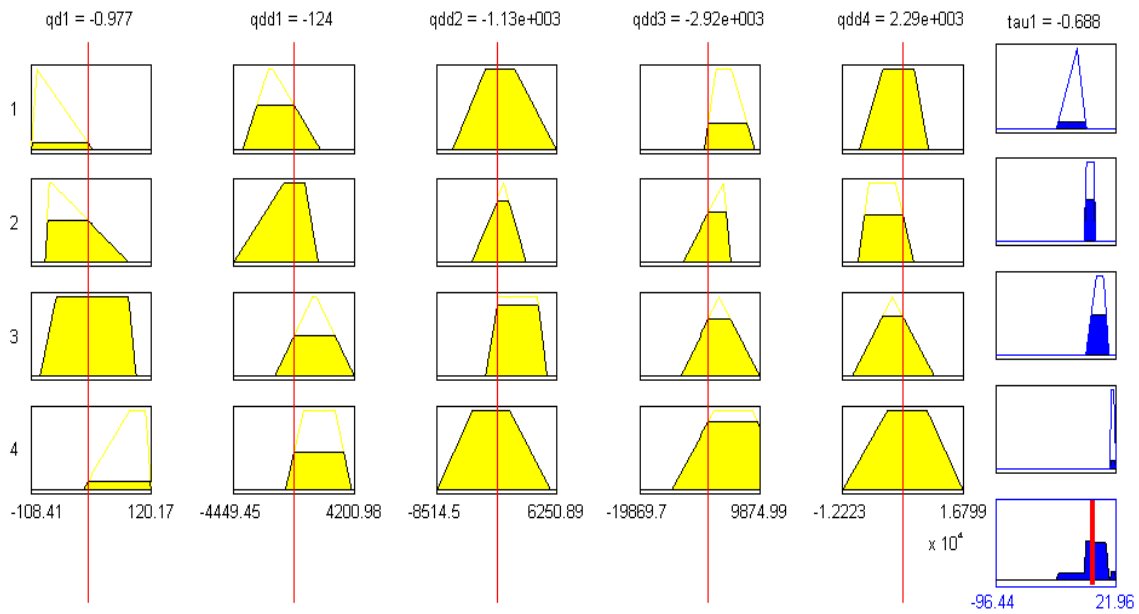

Figure 10 - Functions of Pertinence of the Joint 1.

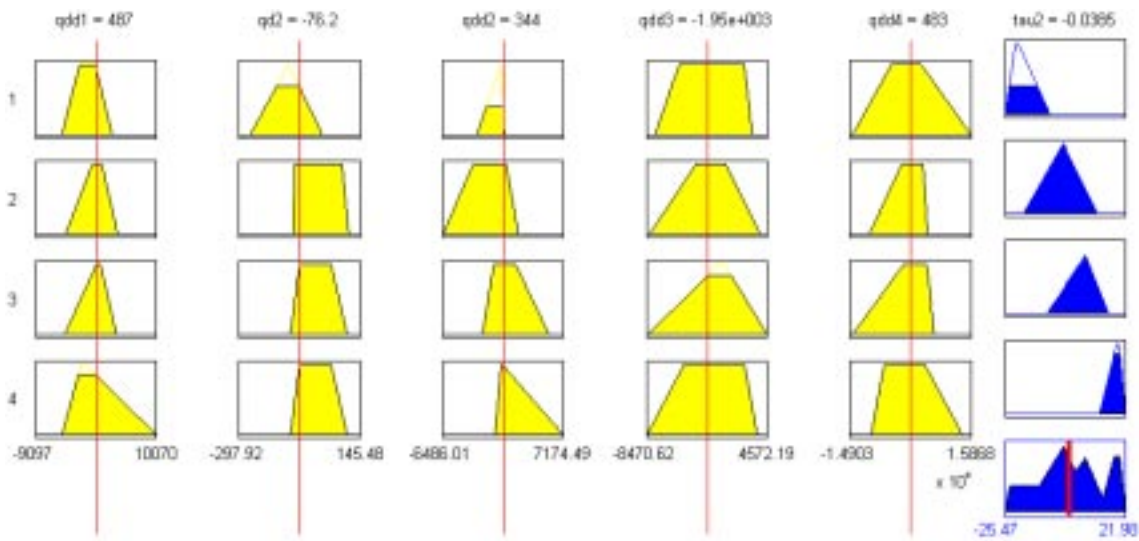

Figure 11 - Functions of Pertinence of the Joint 2.

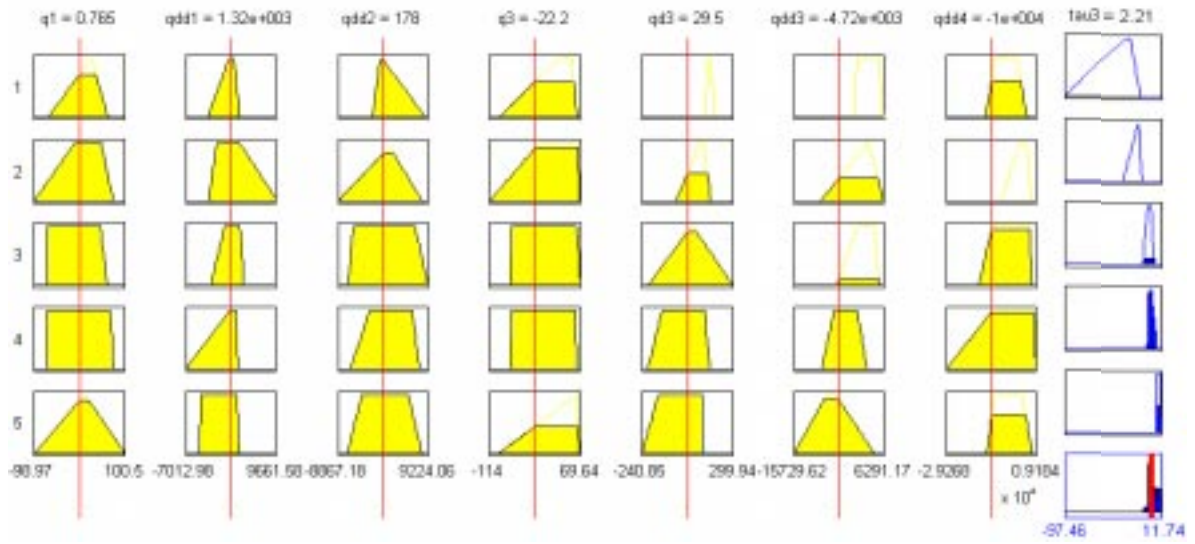

Figure 12 - Functions of Pertinence of the Joint 3.

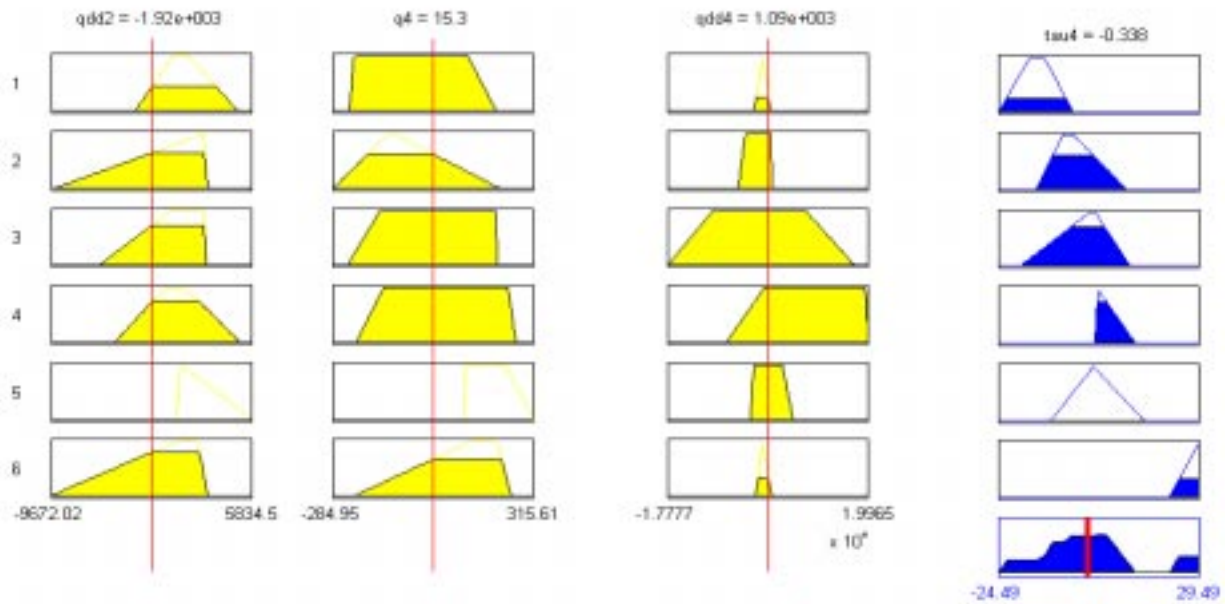

Figure 13 – Functions of Pertinence of the Joint 4.

In the Figure (14) an example of a surface of rules is given, for the variables $qd1$ (\dot{q}_1) and $qdd1$ (\ddot{q}_1) of the joint 1.

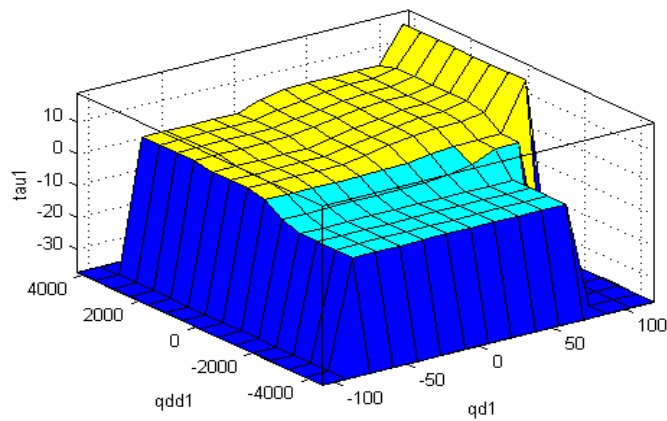

Figure 14 - Surface of Rules of the Joint 1 for Speed and Acceleration of the Joint 1.

7 - Simulation and Results

The software used for the simulation and presentation of the results, it was *Matlab 5*, being used the rules of Mamdani. The control system for the simulation was elaborated in *Simulink* of *Matlab*, according to the schematic drawing described in the Figure 15.

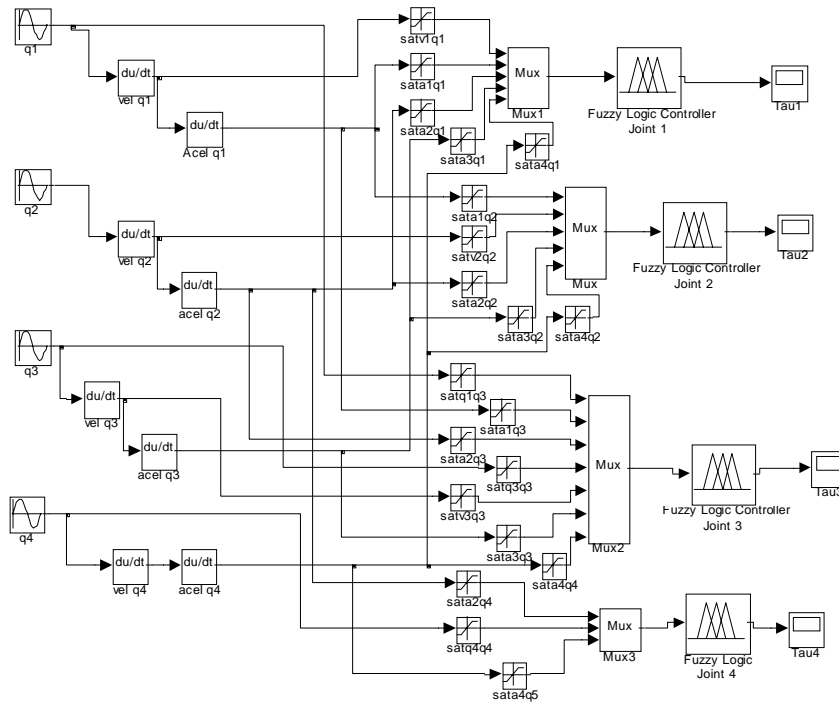

Figure 15 - Diagram of the Simulation of the Model in Fuzzy Logic.

The inputs are given by senoidals functions with amplitude 55° , and different frequency for each joint, as it can be observed in the Figures (16.a ~ 16.d).

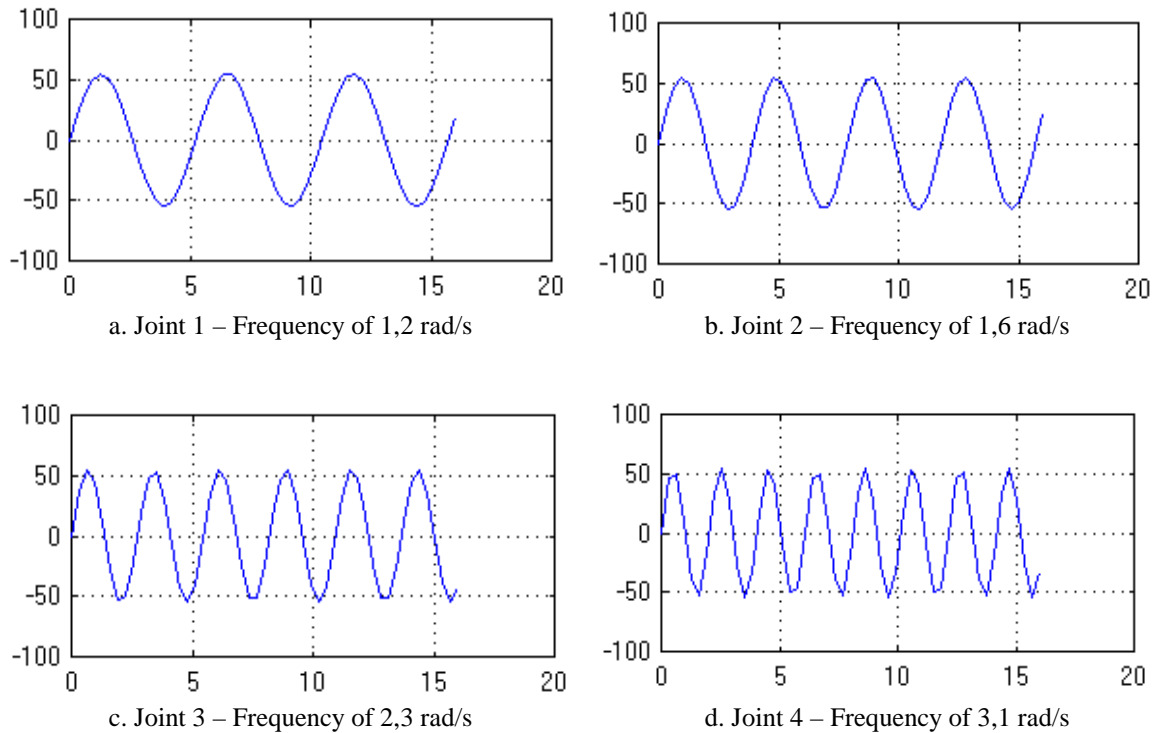

Figure 16 - Input of Inference Fuzzy System (Displacements of the Joints).

The time of simulation of the system was of 16 seconds, and the speeds and acelarations were derived starting from the displacements, as it can be observed in the schematic diagram presented in the Figure (15).

The final answer of the system, in other words, the torque of the joints, can be observed in the Illustrations (17.a ~17.d).

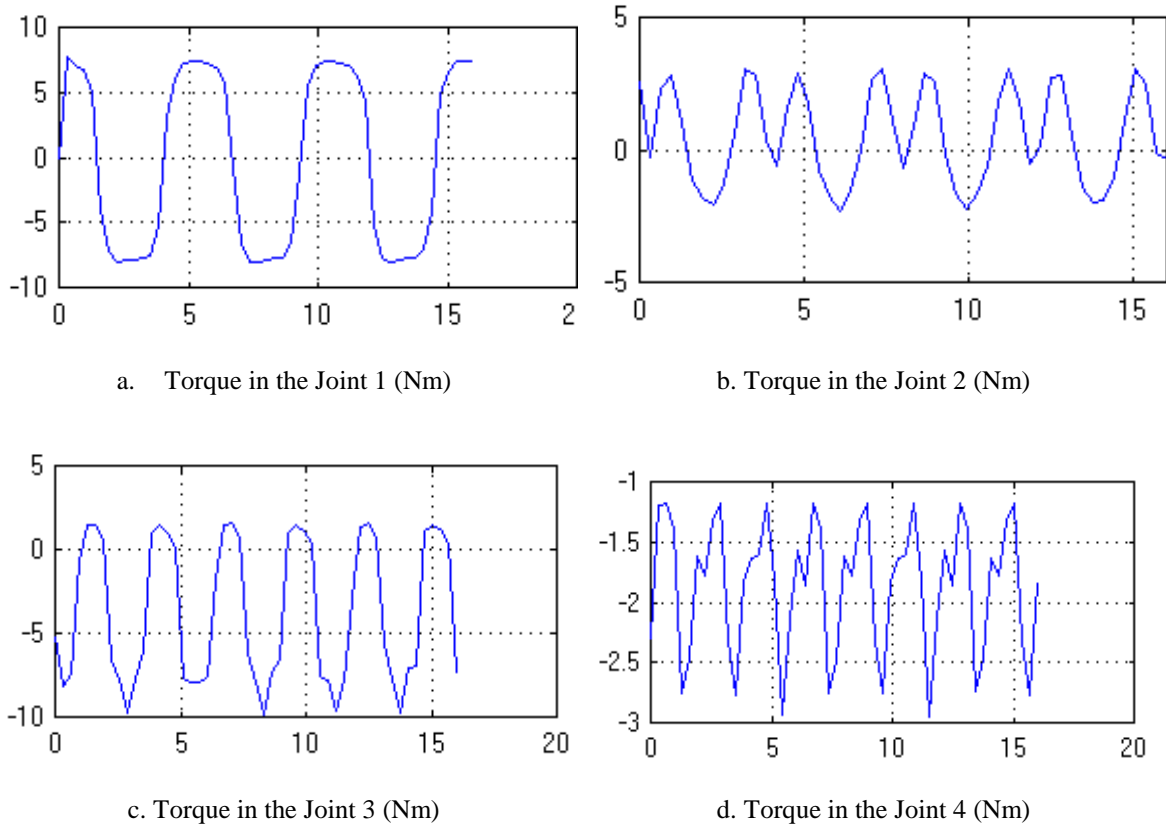

Figure 17. Output of Inference Fuzzy System (Torque in the joints).

8 - Conclusion

In this work had as purpose to present a form of identification of models, starting from the modeling of the inverse dynamics of a robotic manipulator with 4 degrees of freedom, using the partitionement technique for fuzzy logic. Unhappily, the results of the fuzzy model could not be compared with the one of the analytic model and of the experimental data, due to lack of information of the analyzed model (the manipulator's data, such as length and mass of the links, etc).

The modeling of inverse dynamics through fuzzy logic, by partitionement process is simpler than the analytic when it has many degrees of freedom, besides considering the effects non lineal and stochastic (rest and friction) obtained starting from the experimental data.

The implementation of an algorithm that generates a system of fuzzy inference by partitionement of the data, is extremely interesting, due to complexity of determining certain parameters as the centers of the partitions, the pertinence degree, the weight of the fuzzification exponent and other, besides those that are used to determine the pertinence functions.

Therefore, a next step would be the implementation of a flexible algorithm that it allowed to generate the identification of a robotic manipulator, be in the aspect dynamic or cinematic, through a mass of experimental data.

9 – Bibliography

- SILVA, C.W., 1995, *Applications of Fuzzy Logic in the Control of Robotic Manipulator*, Fuzzy Sets and Systems 70, pp 223-234, Elsevier Science;
- EMAMI, M.R., GOLDENBERG, A.A., TÜRKSEN, I.B., 2000, *Systematic Design and Analysis of Fuzzy-Logic Control and Application to Robotics, Part I. Modeling*, Robotics and Autonomous Systems, pp 65-88, Elsevier Science;
- MUSCATO, G., 1999, *Fuzzy Control of an Underactuated Robot with a Fuzzy Microcontroller*, Microprocessors and Microsystems, pp 385-391, Elsevier Science;

- TANSCHKEIT, R., 2001, *Fundamentos de Lógica Fuzzy e Controle Fuzzy*, DEE-PUC-RIO, Rio de Janeiro, Brasil;
- EMAMI, M.R., TÜRKSEN, I.B., GOLDENBERG, A.A., 1998, *Some notes on fuzzy c-means clustering*, IEEE Transactions on Systems, Man, and Cybernetics;
- EMAMI, M.R., TÜRKSEN, I.B., GOLDENBERG, A.A., 1998, *Development of a Systematic Methodology for Fuzzy-Logic Modeling*, IEEE Transactions on Fuzzy Systems;
- ZADEH, L.A., 1973, *Outline of a New Approach to the Analysis of Complex Systems and Decision Processes*, IEEE Transaction on Systems, Man, and Cybernetics, vol. 5;
- LEE, S.H., YI, B.-J., KWAK, Y.K., *Optimal Kinematic Design of an Anthropomorphic*, 1997, *Robot Module with Redundant Actuators*, Mechatronics, vol. 7, no. 5, pp 443-464.