

CONCEPTUAL DESIGN AND FABRICATION OF A ROCKET DE-SPIN SYSTEM

Jorge Roberto Wolf

Instituto de Aeronáutica e Espaço, CTA-IAE, 12228-904, São José dos Campos, SP, jrwolf@iae.cta.br

Alfredo R. de Faria

Departamento de Engenharia Mecânica, Instituto Tecnológico de Aeronáutica, CTA-ITA-IEM, 12228-900, São José dos Campos, SP, arfaria@ita.br

Miguel Ângelo Menezes

Departamento de Engenharia Mecânica, Instituto Tecnológico de Aeronáutica, CTA-ITA-IEM, 12228-900, São José dos Campos, SP, miguelm@ita.br

***Abstract.** The design concept and fabrication issues related to a de-spin system (also known as yo-yo system) to reduce angular velocity (spin) of an in-orbit rocket or satellite right after launch is presented in this article. Requirements related to the launch vehicle design, operational aspects of the launching campaign, inherent characteristics of the yo-yo system, fabrication of the yo-yo system and field testing are addressed. Solutions are proposed for the several items such as the structure of the rotating body to accommodate the yo-yo system, deployment of concentrated masses that effectively reduce spin, external wire release, adjustment of wire lengths, cutting device and materials selection. Comments on testing procedures are given based on the characteristics of design and fabrication of the de-spin system proposed.*

***Keywords:** rocket, de-spin system, dynamics*

1. INTRODUCTION

The Brazilian Space Program has recently received a significant impulse, both in terms of financial as well as human resources [1-3]. The country ambitions to acquire the necessary know-how to design, build, launch and control space vehicles entirely or mostly based on national technology [1]. It is a formidable task given the scientific and specially the technological problems that are certainly to be encountered. Although the country has now a prominent aeronautical industry represented by the well-known aircraft manufacturer Embraer [4], its efforts in the space activities are still somehow shy. Two research institutes are in charge of executing the technical guidelines established for space missions by the federal government: INPE (Instituto Nacional de Pesquisas Espaciais) [5] and IAE (Instituto de Aeronáutica e Espaço) [6]. INPE is more concerned with space satellites whereas IAE is devoted to launchers. A few families of unmanned space rockets have been developed in the past and are being perfected nowadays. However, new concepts and techniques are in demand to build even more reliable and cheaper launchers than the current ones.

The de-spin system proposed in this work falls within the context of innovation towards improved unmanned space launchers. The concept itself has been long proposed as a solution to eliminate the roll component of rotation of space rockets when these devices are about to reach their planned orbit or pathway to space [7]. The roll or spin is necessary to stabilize the rocket during the launch phase. However, it is an undesirable collateral effect that must be efficiently suppressed. The use of thrusters is one option may be either unreliable or expensive since it adds considerable mass to the rocket when compared to the de-spin system. Hence, the de-spin system has the obvious advantage of being lighter and cheaper.

The objective of this work is to present the technical difficulties encountered in the design and fabrication de-spin systems to be mounted on existing members of the family of Brazilian space launchers. The quantitative analysis of the dynamics of such device is not presented but can be found in the specialized literature [7-8].

2. DESIGN AND DE-SPIN SYSTEM REQUIREMENTS

Even though the yo-yo device is a well-known solution to reduce or eliminate spin of rotating bodies, its project must meet a rather wide range of specific missions requirements for a given rocket. Besides, its design must incorporate the design philosophy of its sponsors. The de-spin system is also referred to as yo-yo system for reasons that will become apparent soon.

Vehicle related requirements:

- It must be contained in an independent single module, which can be incorporated in the rocket, given a specific mission profile;
- It must have interfaces suitable for the S-40 and S-43 rocket engines family, in particular to the VS-40 and VLS-1 rockets;
- Its structural rigidity must be compatible with that of the VS-40 and VLS-1 rockets;
- It must have an area with a diameter of 920 mm free of any kind of equipments;
- Its whole weight must be kept to a minimum;
- Both masses must be released within at least 0.5 s after the electrical order.

Operational handling requirements:

- The yo-yo device must be designed in order to be completely assembled in just one hour, by two operators;
- Its assembly must employ average technical resources, both in-country or overseas;
- Before installation in the vehicle, the design must allow last minute parts changing;
- After installation in the vehicle, the design must allow last minute mass adjustments. To do so, the access will be achieved from above, before installation of the satellite or the payload;
- The yo-yo device must be designed in order to be removed after installation of the satellite, if necessary.

Yo-yo device related requirements:

- Both masses have to be released simultaneously;
- Both cables have to be disengaged simultaneously;
- The cable track must be circular, exempt of any kind of saliencies or grooves.

Manufacturing requirements:

- The yo-yo device must be manufactured using techniques and resources available within the Brazilian industry.

Tests requirements:

- All tests must be performed within CTA facilities;
- Vibration and climatic test levels are identical to those from VLS-1.

3. DESIGN SOLUTIONS

3.1. Structure

The module consists of a structure similar to that of the VLS-1 fourth stage front skirt (S-44 engine), albeit shorter. Its upper and lower interfaces are appropriate to be assembled in the vehicles mentioned in section 2. It uses the same material (Aluminium ASTM 6351); with the same heat treatment (T6) and surface finish (Alodine 1200).

The cable track is placed amidships, and it has eight cable guides equally spaced, in order to allow the cables to be properly positioned before and while unwinding, and to prevent them from interlacing during de-spinning. The section of the module is presented in figure 1. The external cable guides are separate parts due to the following reasons:

- To lower milling costs;
- To allow the use of several different cable diameters, thus expanding the yo-yo device application to several mission profiles.

The external cable track allows using cables with diameter up to 3.5 mm; with up to three windings. These values allow it to be applicable to a wide range of rocket flights.

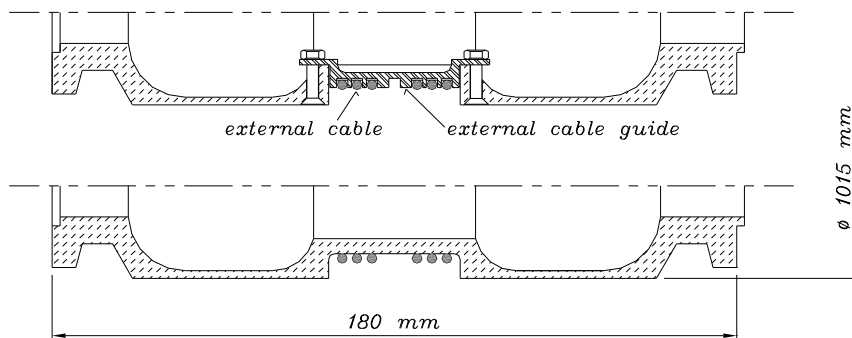

Figure 1. Sections of the proposed yo-yo device module

3.2. Mass Release

It is essential for any yo-yo device to release its masses always simultaneously; otherwise there will be undesirable momentum which will lead to precession. Thus, one event must result in two independent ones; i.e., one command to release the masses must release both at the same time. This was achieved through the linkage of both masses with a single cable, running inside the yo-yo module through several strategically placed small pulleys. This cable is stretched under the application of a known force, which will be discussed later, and it keeps both masses firmly inserted into their respective slots. When the pyrotechnic cable cutter sections the internal cable, both masses are released and as they move out from their wells under the action of centrifugal forces, it allows the external cables to unwind. Since each well is symmetrically placed around the spinning body centre line at 180° , the centrifugal force acting in each mass is the same. In fact, this cable acts as a high elastic constant spring, counterbalancing eventual module deformations once in flight. To stretch the internal cable, two small cable stretchers (with left-right thread) are mounted in both ends, as shown in figure 3. As already mentioned, the internal cable will be stretched with a pre-determined force. Linked to each cable stretcher, there is an “L” shaped lever, which keeps each mass stuck into its well, through the use of a lattice. Figures 2 to 5 show the proposed solution.

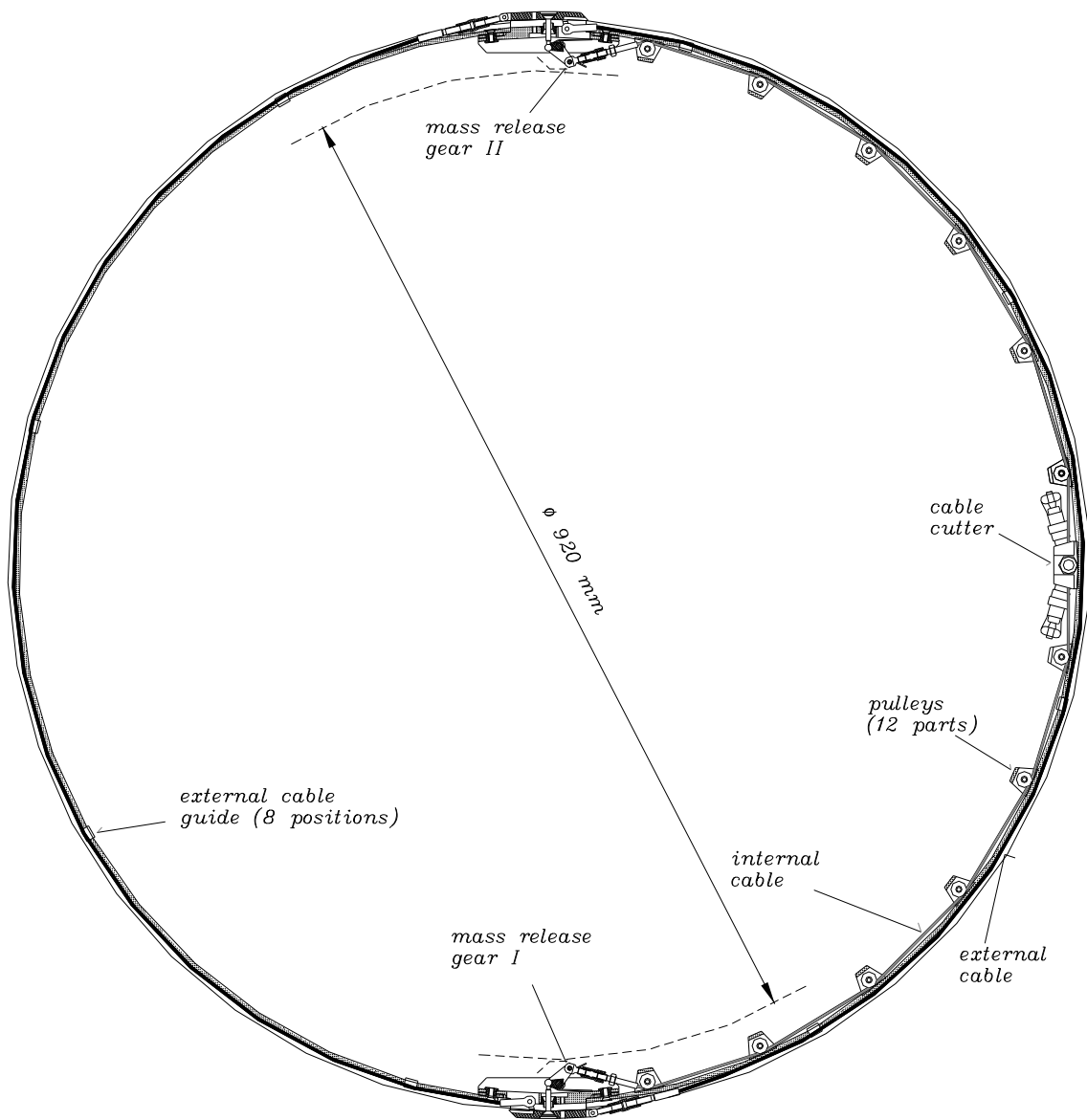

Figure 2. Transverse view of the yo-yo device

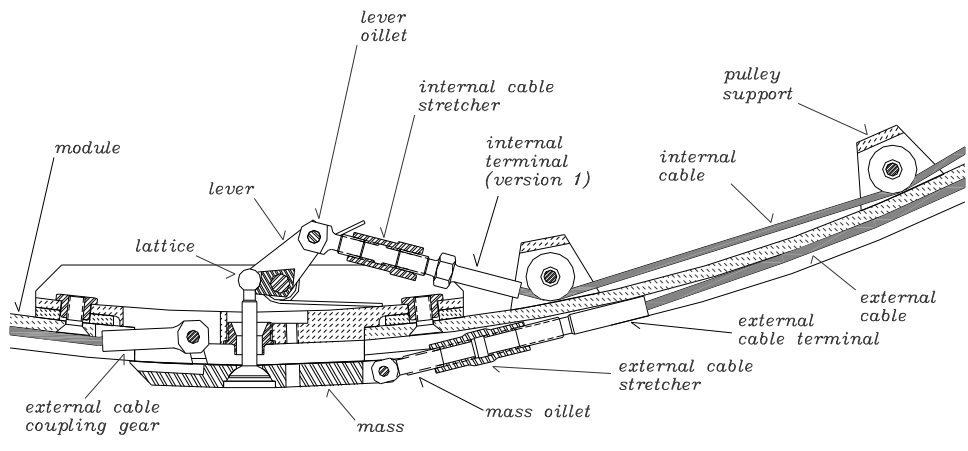

Figure 3. Detail of the release mechanism I

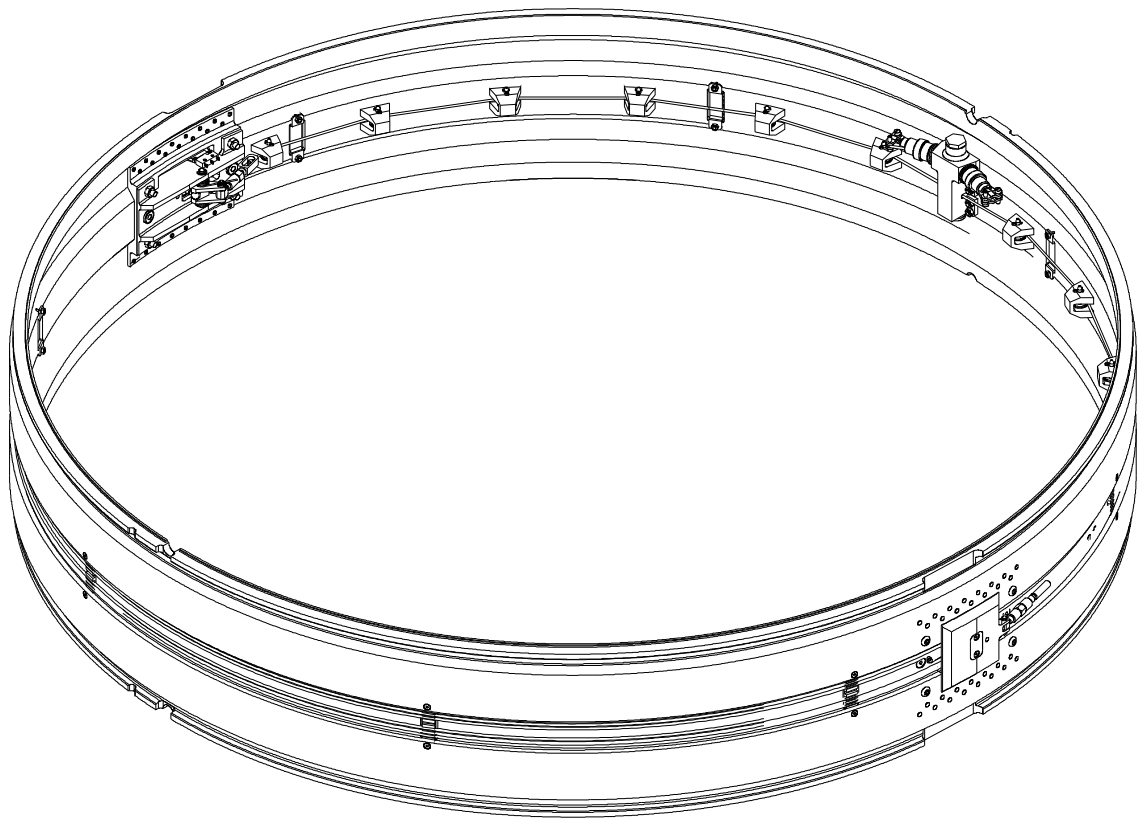

Figure 4. General view of the yo-yo device

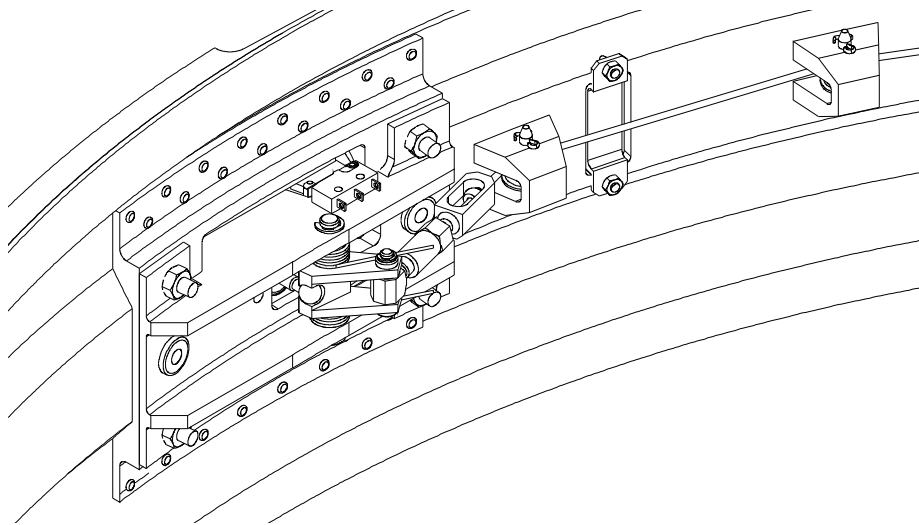

Figure 5. Detail of the release mechanism II

3.3. Disengagement of the external cable

After unwinding completely, both external cables must be disconnected from the yo-yo module, in order to keep the desired angular velocity, and it is very important that this event occurs simultaneously, otherwise the resulting momentum will alter the payload longitudinal axis direction, thus changing its attitude to an unexpected and undesirable position.

Ideally each external cable must be disconnected at an angle of 90° with the yo-yo device plan view. As such, the efficiency of the masses to eliminate the angular velocity reaches its maximum. However, it is believed that a mechanical solution that can effectively guarantee the release at this angle may introduce friction, and this is another variable that may concur to a non simultaneous release.

Thus, it was adopted a compromise where it is known that both cables will not be released after a 90° rotation, but they will be surely released simultaneously. This solution is a very simple one, and it consists in an angled slot, as shown in figure 6.

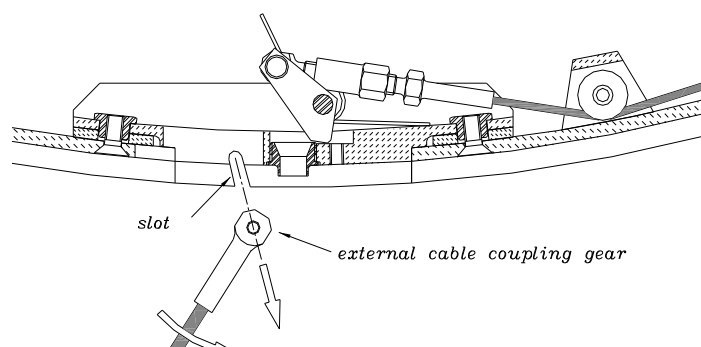

Figure 6. Slot for disengagement of each external cable

3.4. – Length adjustments and pressing terminals in external and internal cables

As already said, the internal cable must be stretched in order to achieve a pre-determined retaining force for each mass. Similarly, both external cables length must be adjusted in order to keep them tightly wound around their tracks in the yo-yo device module. Besides, their lengths must be

equalized in order to disengage at the same time. Therefore, left-right thread cable stretchers were installed in the extremities of all cables, external and internal ones. However, these cable stretchers require appropriate terminal plugs.

The proposed solution is shown in figure 7; it consists in a glove-like plug inserted in the cable extremity, which will be subsequently pressed. The material chosen for this terminal plug is stainless steel 304, due to its good ductile properties. Even though it has low mechanical properties, it is adequate for the expected stresses.

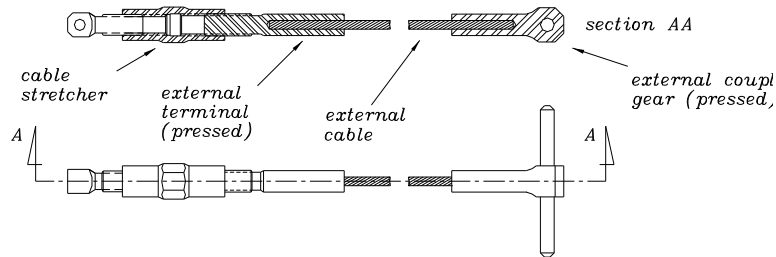

Figure 7. External cable terminal plugs

For the internal cable, two solutions are proposed simultaneously. The first one is similar to that used in the external cable, and the second uses commercially available ball ends. It appears that the second choice will allow a better length dimensional control, since the internal cable requires narrower length tolerance than the external cables. Figure 8 shows both proposed versions.

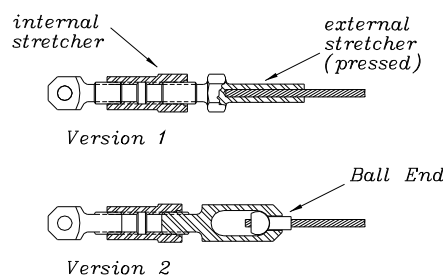

Figure 8. Internal cable terminals

3.5. Pyrotechnic cable cutter

The devised solution for the yo-yo device requires a pyrotechnic cable cutter, as noted above. However, since this specific device was not available, it had to be developed at the same time of the yo-yo device. The proposed solution consists in a hard steel cutter (VD-2, hardened to 60 ~ 63 HRc) inserted in an aluminium body (ASTM 2024 T3). The cutter is secured in place through the aid of a shear pin (ASTM 2024 T4). Inside the body and behind the cutter, there is a chamber into which the gases from the two gas generators (they are doubled in order to achieve redundancy) will pressurize once ignited. The sudden pressure built-up will shear the pin, allowing the cutter to be thrown away into the anvil, placed ahead of the cable. The anvil is less hardened (SAE 4340, 30 ~ 34 HRc) and it will stop the cutter movement, after cutting the cable. Thus the cable will be sectioned with just a single cut, something very desirable from the dynamic release point of view. The section of the pyrotechnic cable cutter is shown in figure 9.

It should be noted that this device must operate properly with only a single gas generator, but must withstand the ignition of two generators.

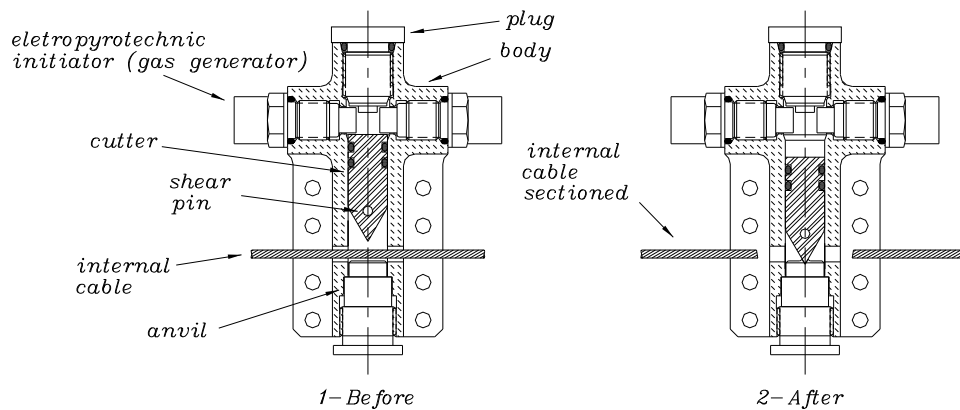

Figure 9. Section of the pyrotechnic cable cutter

3.6. List of the materials

Using figure 3 as a basis, a brief list of the materials used in the yo-yo device design is shown in table 1:

Table 1. Brief description of the materials used in the yo-yo device design

item	material	Heat treatment	finish
Lever	SAE 4340 steel	31 ~ 36 HRc	Bichromation
Pulley axle	SAE 4340 steel	31 ~ 36 HRc	Bichromation
Lever axle	SAE 4340 steel	31 ~ 36 HRc	Bichromation
External cable stretcher	SAE 4340 steel	30 ~ 34 HRc	Bichromation
Internal cable stretcher	SAE 4340 steel	31 ~ 36 HRc	Bichromation
Module	aluminium ASTM 6351	T6	Alodine 1200
Lever oillet	SAE 4340 steel	31 ~ 36 HRc	Bichromation
Mass oillet	SAE 4340 steel	31 ~ 36 HRc	Bichromation
Mass	SAE 4140 steel	30 ~ 34 HRc	Bichromation
Pulley	SAE 4340 steel	39 ~ 43 HRc	Bichromation
Lattice	SAE 4340 steel	31 ~ 36 HRc	Bichromation
Pulley support	aluminium ASTM 2024	T3	Alodine 1200
External cable coupling gear	Stainless steel 304	---	---
External cable	Stainless steel 304	---	---
Internal cable – version 1	Stainless steel 304	---	---
Internal cable – version 2	SAE 4340 steel	31 ~ 36 HRc	Bichromation

All moving parts are lubricated with a thin layer of sprayed molybdenum bisulphite, in order to avoid vacuum cold welding, in addition to minimizing friction among them. Using figure 3 as a basis, a brief list of the materials used in the pyrotechnic cutter device design is shown in table 2:

Table 2. Brief description of the materials used in the pyrotechnic cable cutter device

item	material	Heat treatment	finish
Anvil	SAE 4340 steel	30 ~ 34 HRc	Bicromatização
Body	aluminium ASTM 2024	T3	Alodine 1200
cutter	VD-2 steel	60 ~ 63 HRc	Bicromatização
Shear pin	aluminium ASTM 2024	T4	Alodine 1200
Plug	Stainless steel 304	---	---

4. COMMENTS AND CONCLUSIONS

The design of a yo-yo device entirely contained in a single and independent module was accomplished. It has the appropriate interfaces for both VS-40 and VLS-1 rocket engine family.

It has an area with a diameter of 920 mm free of any kind of equipments, thus allowing it to be assembled or removed even with a payload or satellite with a slightly smaller diameter already installed.

The proposed yo-yo device weights around 10.5 kg. There may have a variation due to the variation in the weight of both masses and the length of the cables, which must be chosen for every specific mission; the module itself contributes with 7.9 kg. However, the solution of a single and independent module implies the addition of a second manacle ring to attach it to the rocket last stage, weighting 4.75 kg. Therefore, the total weight of the installed device is around 15.25 kg.

The device assembly procedure is simple, requires two operators at maximum (to wind the external cables in their tracks, since both cables must be winded simultaneously).

The device requires around 30 min to be assembled within the launch site facilities. Sub-assemblies like the cable cutter, internal and external cables must have been prepared beforehand, however, but this follows the rocket assembly procedure.

Any parts can be adjusted or changed at any time, provided that the device upper interface is accessible.

5. REFERENCES

- [1] DOLINSKY, M. M. **IAE – presença brasileira no espaço**. São José dos Campos: IAE, 1992 (report 003/AVD-P/92).
- [2] BOSCOV, JAIME. **Estudo analítico prospectivo da área aeroespacial – segmento lançadores**. São José dos Campos: IAE, 1998 - Curso de Reciclagem em Tecnologia Espacial, FUNCATE-CTA/IAE.
- [3] PALMÉRIO, A. F. **Introdução à Tecnologia de Foguetes**. 4th.ed. São José dos Campos: IAE, 2004. Handout of course notes.
- [4] EMBRAER – Empresa Brasileira de Aeronáutica. Website of private corporation. Available at: <http://www.embraer.com>. Access on September 30, 2006.
- [5] INPE – Instituto Nacional de Pesquisas Espaciais. Website of Brazilian public research institute. Available at: <http://www.inpe.br>. Access on September 30, 2006.
- [6] IAE – Instituto de Aeronáutica e Espaço. Website of Brazilian public research institute. Available at: <http://www.iae.cta.br>. Access on September 30, 2006.
- [7] FEDOR, J. V. **Theory and design curves for a yo-yo de-spin mechanism for satellites**. Maryland: NASA, 1961 (NASA Technical Note D-708).
- [8] WOLF, J. R. **Anteprojeto e projeto de um sistema redutor de velocidade angular para foguetes**. São José dos Campos: ITA, Dec. 2005 (CTA/ITA-IEM/TM-024/2005).